

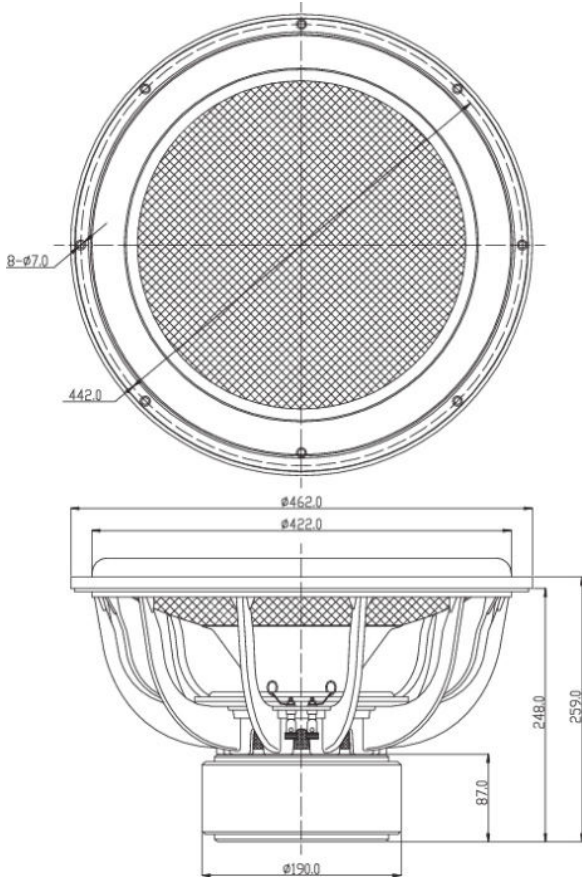

UM18-22 18" Ultimax DVC Subwoofer 2 Ohms Per Coil

UM18-22



PARAMETERS

Impedance	2 + 2 ohms
Re	4.3 ohms
Le	1.5 mH @ 1 kHz
Fs	26.2 Hz
Qms	4.05
Qes	0.85
Qts	0.70
Mms	532g
Cms	0.07 mm/N
Sd	1,219 cm ²
Vd	2,681 cm ³
BL	21.1 Tm
Vas	144.7 liters
Xmax	22 mm
VC Diameter	75 mm
SPL	89.5 dB @ 2.83V/1m
RMS Power Handling	1,000 watts
Usable Frequency Range (Hz)	19 - 500 Hz

FEATURES

- 18" design for enormous air movement
- Over 2" of total cone travel!
- 1000 watts RMS power handling
- Dual mirror-imaged linear spiders ensure distortion-free excursion
- Dual 2 ohm, 2-layer copper voice coils

IMPEDANCE/PHASE

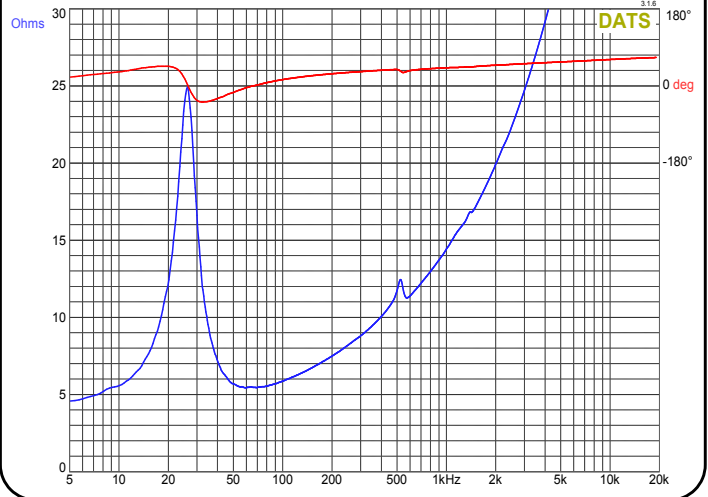

FREQUENCY RESPONSE

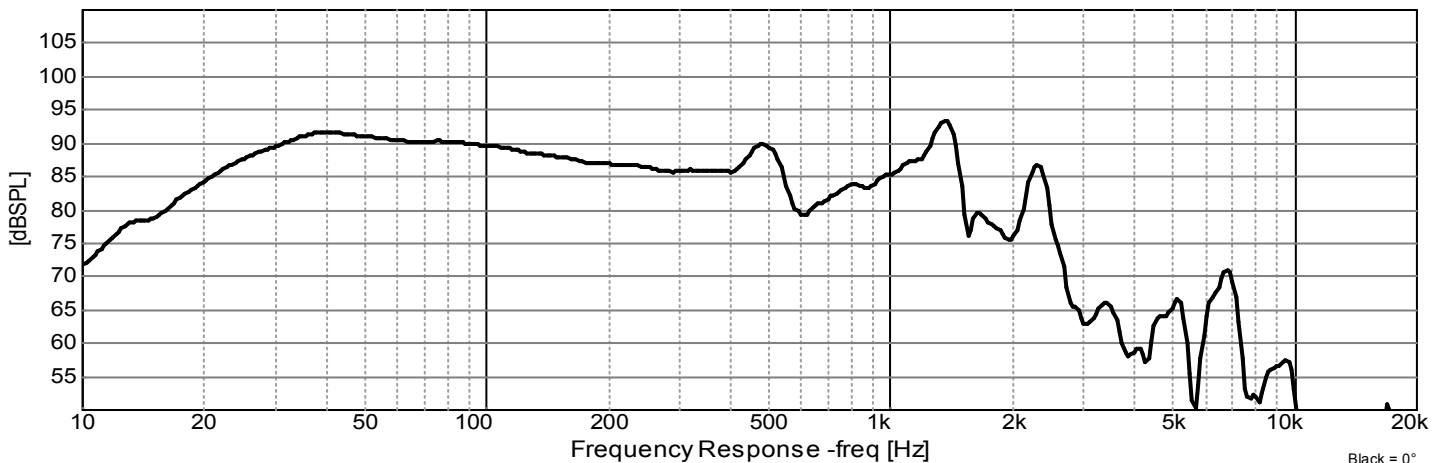

Note: 1/24th octave smoothing - nearfield response included in graph below 450 Hz.

Note: All parameters derived with voice coils wired in series