

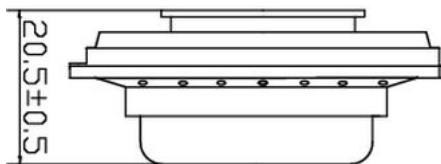

DAEX25VT-4 Vented 25mm Exciter 20W 4 Ohm

DAEX25VT-4

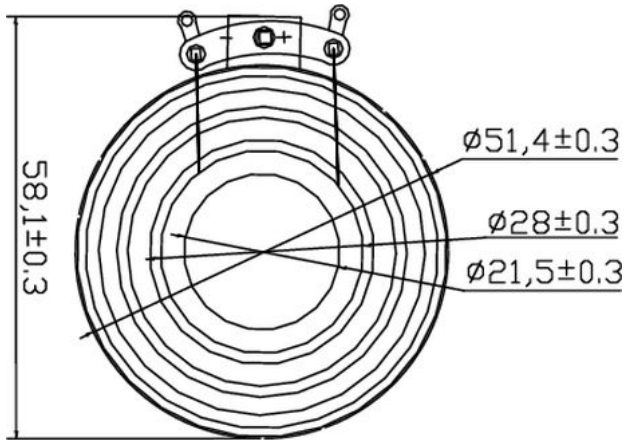

PARAMETERS

Impedance	4 ohms
Re	4.2 ohms
Le	0.24 mH @ 1 kHz
Fs	230 Hz
Qms	N/A
Qes	N/A
Qts	0.83
Mms	1.75 g
Cms	0.0003 mm/N
Sd	N/A
Vd	N/A
BL	3.86 Tm
Vas	N/A
Xmax	N/A
VC Diameter	25 mm
SPL	N/A
RMS Power Handling	20 watts
Usable Frequency Range (Hz)	N/A

FEATURES

- Small size; just over 2" diameter, about 7/8" high
- Pre-applied 3M™ VHB™ adhesive for quick, secure installation
- Rare-earth neodymium motor and a proprietary voice coil
- 4 ohms impedance for use with small, Class D amplifiers
- 20 watt RMS power handling for high output

APPLICATIONS

- Invisible home theater and multi-room audio
- Electronic gaming machines
- Advertising signage
- Point-of-purchase displays
- Multimedia exhibits
- Commercial distributed audio
- Kiosks
- Automotive audio
- Bathroom tubs and showers

IMPEDANCE/PHASE

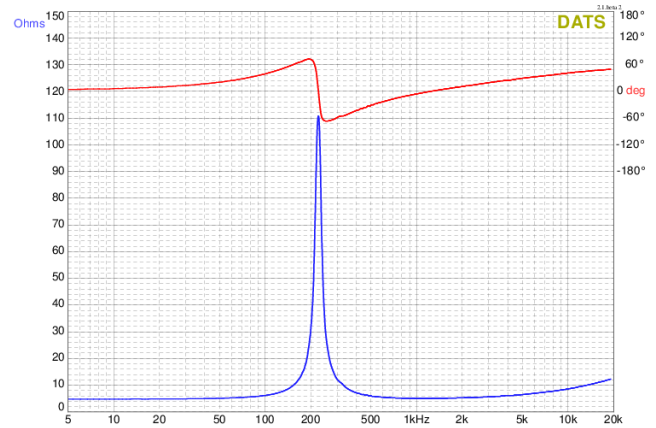

Measurement taken with transducer uncoupled facing upward.

FREQUENCY RESPONSE

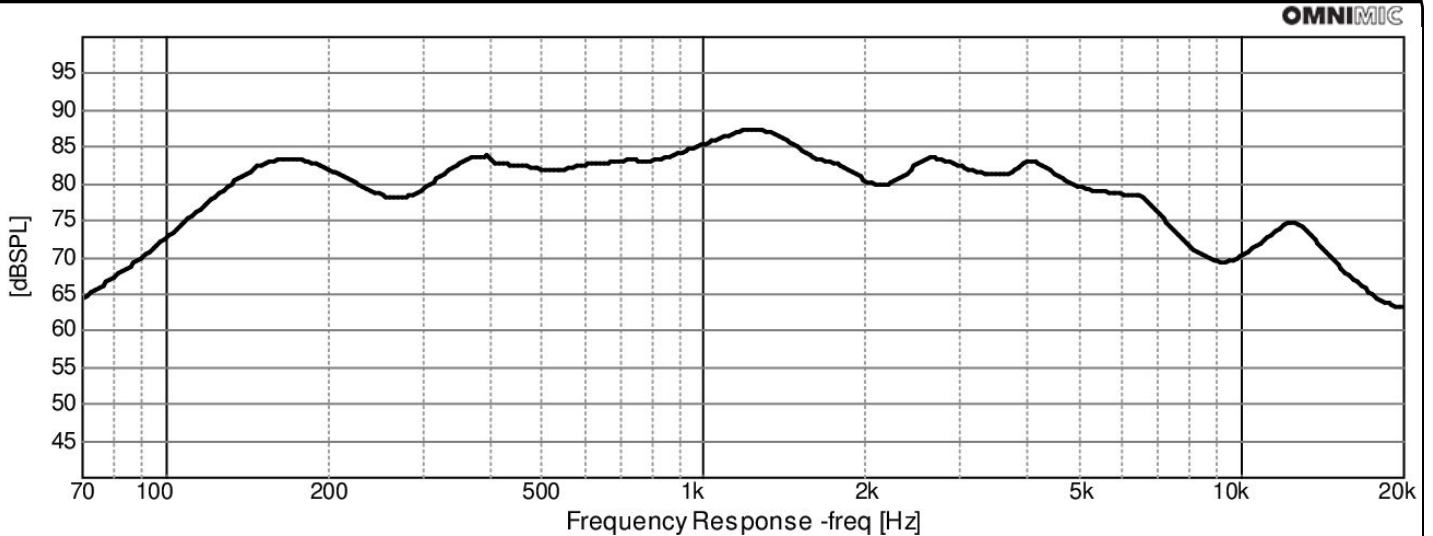

OmniMic

1/3rd octave smoothing - measurement taken with transducer adhered off-center on a 12" x 12" x 1/2" foam core board in an infinite baffle setup.

Note: This information is for comparison purposes only, the actual frequency response will depend on many factors of which the diaphragm being the greatest contributor.