

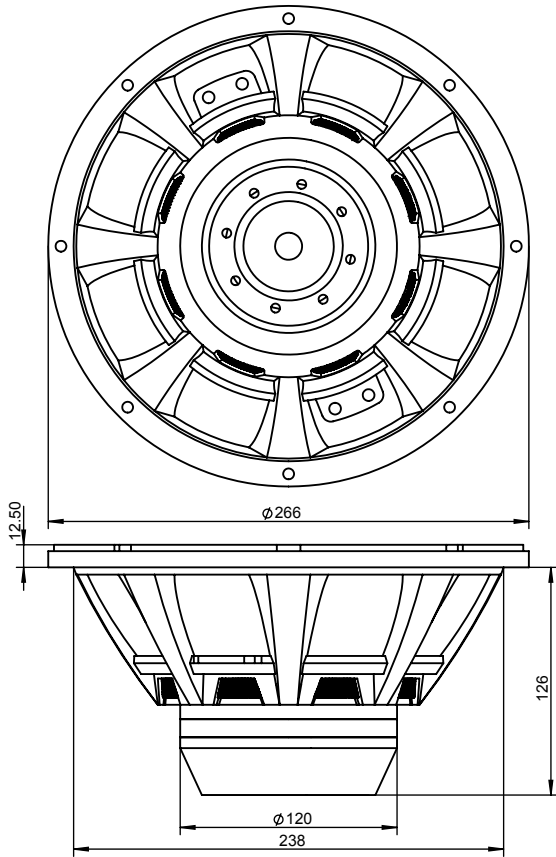

Apollo 10N 10" Professional Neodymium Midbass Woofer 8 Ohm

10MB250N-8



PARAMETERS

Impedance	8 ohms
Re	7.4 ohms
Le	1.12 mH @ 1kHz
Fs	54 Hz
Qms	6.73
Qes	0.23
Qts	0.22
Mms	34.2 g
Cms	0.258 mm/N
Sd	333.12 cm ²
Vd	191.4 cm ³
BL	19.2 Tm
Vas	43.49 liters
Xmax	5.79 mm*
Magnetic Gap Height	8 mm
VC Diameter	2.5"
VC Winding Height	14 mm
SPL	96.5 dB @ 2.83V/1m
RMS Power Handling	250 watts
Usable Frequency Range	60Hz-4.2kHz

* Klippel verified

FEATURES

- Powerful neodymium motor for superior output
- Copper inductance cap for low distortion
- Paper cone and cloth m-roll surround for high clarity, smooth response, and linear excursion for pounds of punch
- 2.5" Inside/outside wound copper voice coil on fiberglass former lends solid power handling capability
- Under spider and rear periphery venting allow for a cooler running voice coil
- Low Qts means high damping and smaller boxes

IMPEDANCE/PHASE

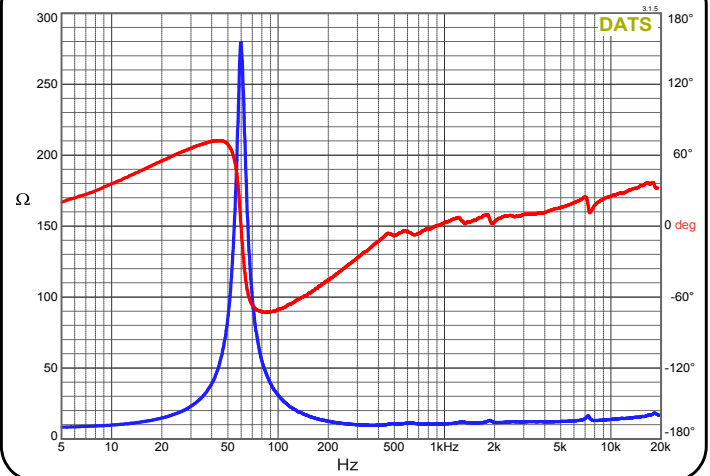

FREQUENCY RESPONSE

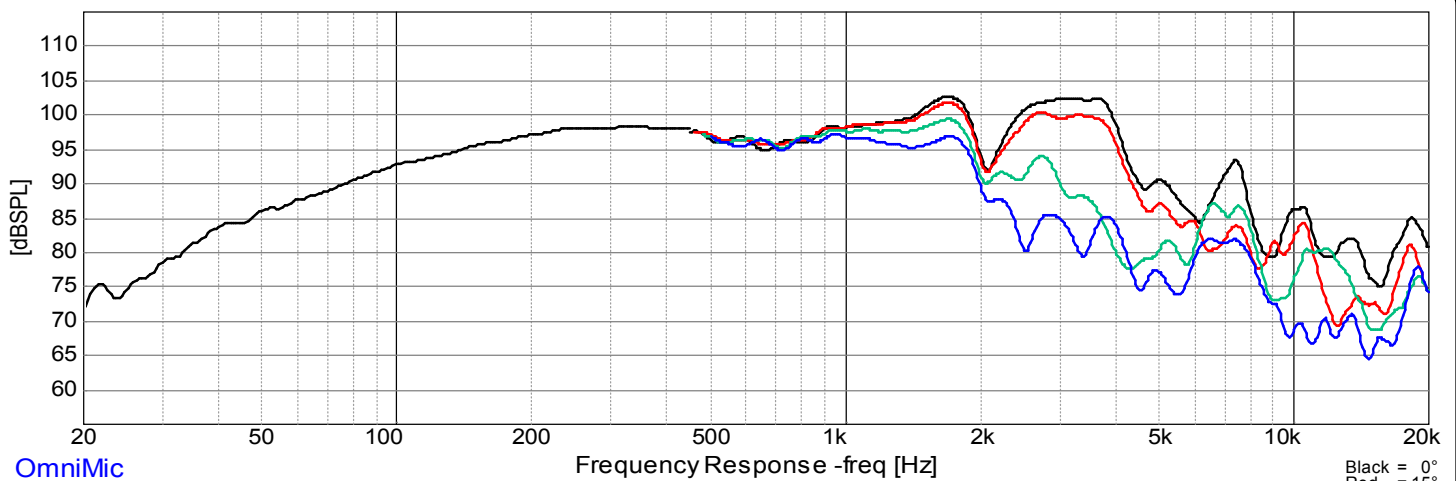

OmniMic

Note: 1/12th octave smoothing - nearfield response included in graph below 450 Hz

Black = 0°
Red = 15°
Green = 30°
Blue = 45°