

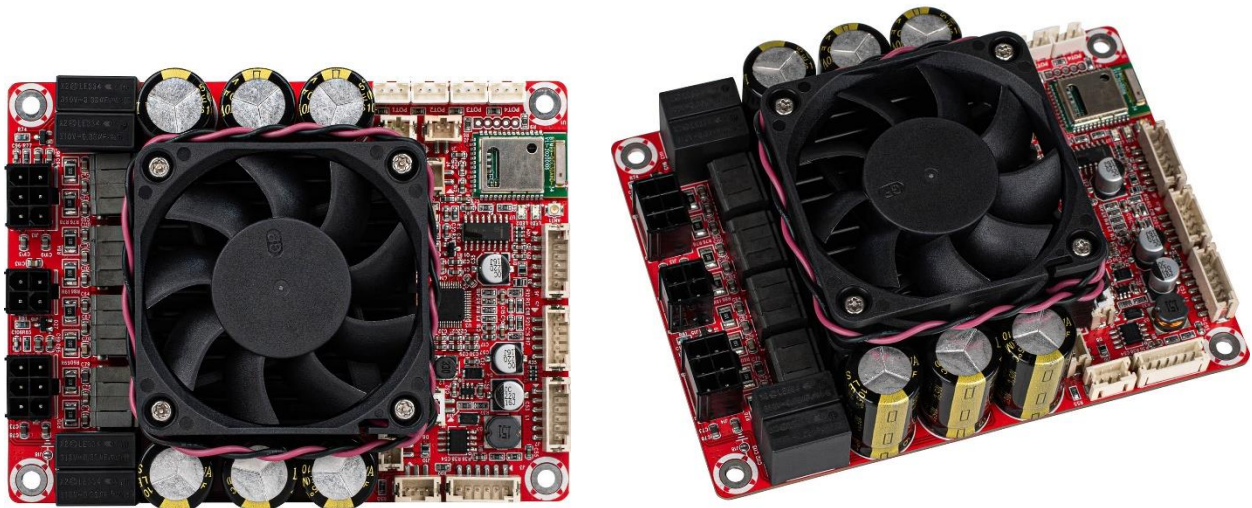

## KABD-4100 User Guide

The new Dayton Audio KABD series of boards leverages the convenience of Bluetooth 5.0 with aptX HD streaming along with the powerful Analog Devices ADAU1701 DSP chip to allow for almost limitless possibilities for sound customization and still have the convenience of high-quality Bluetooth streaming. Out of the box, basic customizations and volume control can be made by attaching the optional potentiometers, but to unlock the full potential of your amplifier, attach an ICP1 or KPX programming board to program your KABD amplifier with the SigmaStudio development tool from Analog Devices. This allows for limitless possibilities of EQ, limiting, bass enhancement, delays and more.

This guide applies to the KABD-4100, which is a configurable 4 channel amplifier capable of multiple output modes. 4 x 100 Watts (4CH), 2 x 100 Watts + 1 x 200 Watts(2.1CH), or 2 x 200 Watts (2CH).



# Table of Contents

KABD-4100 Visual Overview .....	4
Quick Start and Wiring Guide .....	5
Before You Start.....	5
Power Supplies.....	5
Input Devices.....	5
Speaker Outputs .....	6
Quick Start Steps.....	7
Potentiometer Headers .....	12
Potentiometer Port Configuration in SigmaStudio.....	13
Using the Potentiometer Ports for Connecting Buttons or Switches .....	13
Sigma Studio Connection - Quick Start .....	14
Default Register Configuration in SigmaStudio .....	17
Writing to E2Prom – Burning Custom SigmaStudio Programs to Non-Volatile Memory.....	18
Cascading 2 KABD-4100 Amps for up to 8 Channels .....	20
Using SigmaStudio while in KABD-4100 Cascaded mode .....	22
Cascaded KABD-4100 Troubleshooting .....	23
Example Projects Types for the KABD-4100 .....	24
2.1 Systems .....	24
Active 2-Way Monitors, Bookshelf Speakers, Tower Speakers, etc .....	25
Mono 3-Way Speaker .....	26
Stereo Pair of active 3-Way Towers By Cascading 2 KABD-4100 Amps.....	26
Customized, High Power Amplifier .....	26
Example SigmaStudio Projects.....	27
SigmaStudio Programming Guide .....	27
Specifications .....	28

## What is new with the KABD amps compared to the DSPB series?

The DSPB series was the first generation of DSP amplifier boards from Dayton Audio, and the KABD series builds on the success of that series by adding new features such as Bluetooth 5.0 and boards capable of up to 4 channels of amplification.

1. Potentiometers have been removed from the board, and replaced with 3-pin JST ports. In the optional cable pack for the KABD series, there are 4 potentiometers with cables to connect directly to these ports, no soldering required. This allows for convenient external volume controls, filter controls and more. It also allows easy access to multipurpose pins of the ADAU1701 for other purposes.
2. Bluetooth 5.0 with AptX HD streaming. High quality Bluetooth streaming is now built right onto the board. Example projects have been updated accordingly to use this input. If your SigmaStudio project is not setup correctly, you will not hear any input when connected with Bluetooth.
3. 4 Channels of amplification! Perfect for making a stereo pair of 2-way active speakers, both of the new 4 channel amplifiers use the BT 5.0 module w/aptX HD, and also allow for external potentiometers. The boards can also be configured into 2.1 mode, or higher powered 2.0 mode. Each board is smaller than a typical passive 2-way crossover, yet you get amplification, DSP and Bluetooth built in with no passive crossovers required. Make a crossover with DSP instead!
  - a) The KABD-430 will allow for 4 x 30 Watt channels of DSP and amplification in the same compact size as any previous KAB or DSPB amplifier. Configurable as 4x30W, 2x30W+1x60W, or 2x60W.
  - b) The KABD-4100 is a larger board, but allows for up to 4 x 100 Watts of DSP and amplification! Configurable as 4x100W, 2x100W + 1x200W, or 2x200W. This amplifier can also be cascaded with a second KABD-4100 for up to 8 channels of amplification.

## What is the difference between a KABD amp and a KAB amp?

Dayton Audio's original line of Bluetooth amplifier boards is the KAB line, which have had numerous generations but always included class D amplification optimized for portable use and Bluetooth streaming. Compared to the KAB series, the KABD series of amps all include a dedicated DSP chip called the Analog Device's ADAU1701, which allows for connection to SigmaStudio and incredibly flexible DSP configuration such as on-the-fly tone controls, advanced bass processing, delays, etc. The previous DSPB series of amplifiers also employed this ADAU1701 DSP module, however it lacked Bluetooth support. The KABD series is like a combination of the KAB and DSPB series. The newest generation of KAB amplifiers employ the same Bluetooth 5.0 chips with aptX streaming and very similar connections, and for the first time, this generation of KAB also includes basic EQ capability with the KPX programmer (however it is not nearly as powerful or flexible as the ADAU1701).

# KABD-4100 Visual Overview

I2S (Digital) Input Slave Mode Only	
J6 PH-6Pos-2mm	
Pin	Definition
1	MCLK
2	+5V
3	GND
4	DATA1
5	BCLK
6	LRCLK

Line Input	
J5 PH-5Pos-2mm	
Pin	Definition
1	IN LEFT
2	AGND
3	IN RIGHT
4	NC
5	NC

I2S (Digital) Output	
J7 PH-6Pos-2mm	
Pin	Definition
1	MCLK
2	+5V
3	GND
4	DATA0
5	BCLK
6	LRCLK

LEFT = DIG0, RIGHT = DIG1

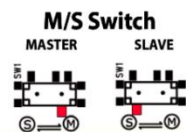

BT Disconnect	
J4 PH-2Pos-2mm	
Pin	Definition
1	Cancel
2	+3.3V

POT / GPIO Ports	
POT 1-4 PH-3Pos-2mm	
Pin	Definition
1	GND
2	MP9, MP8, MP3, MP2
3	3.3V

External BT LED	
J1 PH-2POS-2mm	
Pin	Definition
1	LED+
2	LED-

External Signal LED	
J12 PH-2POS-2mm	
Pin	Definition
1	LED+
2	LED-

Programming	
J3 via ICP1 or KPX programmer PH-6Pos-2mm	
Pin	Definition
1	RST
2	+5V
3	GND
4	WP
5	SCL
6	SDA

Mute & Sync	
J10 PH-3Pin-2mm	
Pin	Definition
1	STBY
2	GND
3	MUTE

Standby Control	
J11 PH-2POS-2mm	
Pin	Definition
1	STBY
2	GND

PORT#	POT1-4 Input Name	ADAU1701 GPIO PIN
POT1	AUX_ADC_3	GPIO8 / MP8
POT2	AUX_ADC_2	GPIO2 / MP2
POT3	AUX_ADC_1	GPIO3 / MP3
POT4	AUX_ADC_0	GPIO9 / MP9

Speaker Output				
J13 Molex-MiniFit-2x3Pos-3mm				
Pin	Stereo Mode		Mono Mode	
	Function	ADAU1701 Output	Function	ADAU1701 Output
1	MODE2		MODE2	
2	GND	N/A	GND	N/A
3	OUTL2-	DAC2	MONO2-	DAC2
4	OUTL2+		MONO2+	
5	OUTR2-		MONO2-	
6	OUTR2+	DAC3	MONO2+	

DC Power (12-36V)	
J15 Molex-4Pos-3mm	
Pin	Definition
1	GND
2	GND
3	VCC
4	VCC

Speaker Output				
J14 Molex-MiniFit-2x3Pos-3mm				
Pin	Stereo Mode		Mono Mode	
	Function	ADAU1701 Output	Function	ADAU1701 Output
1	MODE1		MODE1	DAC0
2	GND	N/A	GND	
3	OUTL1-	DAC0	MONO1-	
4	OUTL1+		MONO1+	
5	OUTR1-	DAC1	MONO1-	
6	OUTR1+		MONO1+	

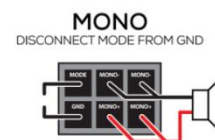
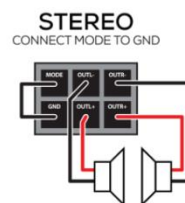
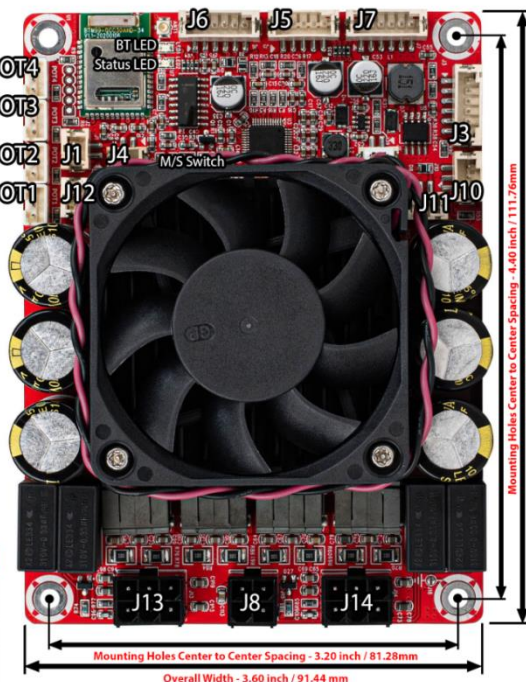

# Quick Start and Wiring Guide

## Before You Start

- Make sure that any speakers and input devices you plan on connecting to the KABD are working properly.
- If using SigmaStudio to use the full potential of the DSP, make sure you have purchased at least one programmer board (ICP1 or KPX), an appropriate USB cable capable of data transfer and make sure you have a Windows PC available to use for Analog Devices' free SigmaStudio software.
- Take care when attaching and especially removing jumper cables from the KABD.
  - A damaged cable can cause issues that are difficult to troubleshoot, such as noises like popping or clicking. A damaged cable can also cause programming failure.
  - A rocking motion can be helpful when removing cables from ports.
- Note that there is a 'tips and troubleshooting' section at the bottom of this document.
- This guide will frequently reference ports on the amplifier such as "J8" or "J6". These markings are written on the board itself in small print and are usually easy to find, but if unsure, reference the quick start wiring diagram below.

## Power Supplies

- **DC Power** - The KABD-4100 can be powered via J15 using the included wiring harness and DC jack with a DC power supply from 10-39V with current capabilities greater than 1A. Any power supply outside of this specification can damage the KABD-4100. In general, the higher wattage the power supply, the more power that can be supplied to your speaker.
- **For maximum power, use a high quality 36V 10A Power Supply.**

## Input Devices

- **Bluetooth** - The KABD-4100 has Bluetooth 5.0 built directly onto the board wired directly to the ADAU1701 DSP chip via I2S. This supports apt-X, aptX-HD, apt-X LL, SBC and AAC.
- **Analog** - Analog audio sources can be input to the KABD-4100 via J5. A 3.5mm aux-in cable is available in the function cables kit for the KABD series.
- **Mixing** - By default, input from I2S (Bluetooth) and J5 (analog) are mixed together within the DSP before being sent for amplification. This allows for a smooth transition between aux and Bluetooth without the user needing to touch the speaker/amplifier. This can be reprogrammed via a custom SigmaStudio project. For example, you might use a switch to change between Bluetooth and AUX (analog). See the example projects pack for an example SigmaStudio project.

## Speaker Outputs

Speaker Output				
J13				
Molex-MiniFit-2x3Pos-3mm				
Pin	Stereo Mode		Mono Mode	
	Function	ADAU1701 Output	Function	ADAU1701 Output
1	MODE2	N/A	MODE2	N/A
2	GND		GND	
3	OUTL2-	DAC2	MONO2-	DAC2
4	OUTL2+		MONO2+	
5	OUTR2-	MONO2-		
6	OUTR2+	MONO2+		

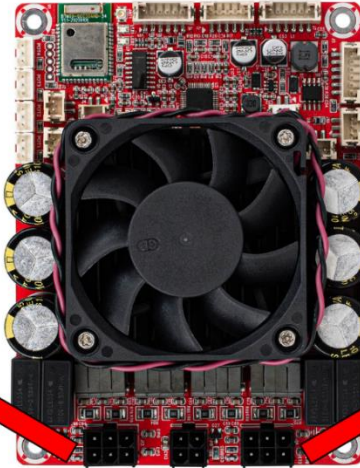

Speaker Output				
J14				
Molex-MiniFit-2x3Pos-3mm				
Pin	Stereo Mode		Mono Mode	
	Function	ADAU1701 Output	Function	ADAU1701 Output
1	MODE1	N/A	MODE1	N/A
2	GND		GND	
3	OUTL1-	DAC0	MONO1-	DAC0
4	OUTL1+		MONO1+	
5	OUTR1-	DAC1	MONO1-	
6	OUTR1+		MONO1+	

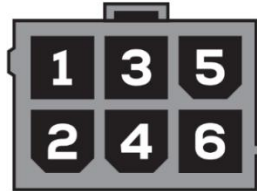

- The KABD-4100 has 2 separate speaker output jacks (J13 and J14). These jacks are each attached to their own stereo amplifier modules for a total of 4 output channels. Each port also supports PBTl (bridged mode), allowing the KABD-4100 to be configured into 4.0, 2.1, or even 2.0 configurations.
- Pins 1 and 2 of the speaker output jacks will control the output mode. The included speaker wiring harnesses (shown below) include male/female jumper connections to make configuring the output mode of each port simple. For stereo mode, connect the jumper wires together. For bridged/mono mode, leave them disconnected.
- The speaker outputs of the KABD-4100 are stable down to 4 Ohm.



**STEREO**  
CONNECT MODE TO GND

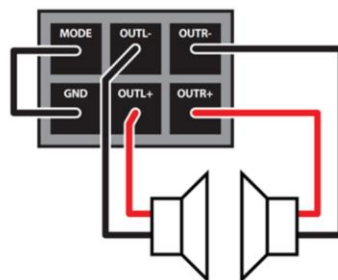

**MONO**  
DISCONNECT MODE FROM GND

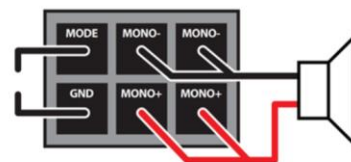

# Quick Start Steps

## 1 Speaker Connection

Using the included wiring harnesses, wire your speakers to the harness as described in the section directly above. Connect the jumper for stereo mode on that port, or leave the jumper disconnected for mono mode.

Do not let speaker wires touch while the amplifier is powered. Do not switch the output mode while the amplifier is powered. Attach the wiring harness to your speakers before connecting to your KABD.

The minimum impedance of connected speakers is 4 Ohm in both Stereo and Mono Mode

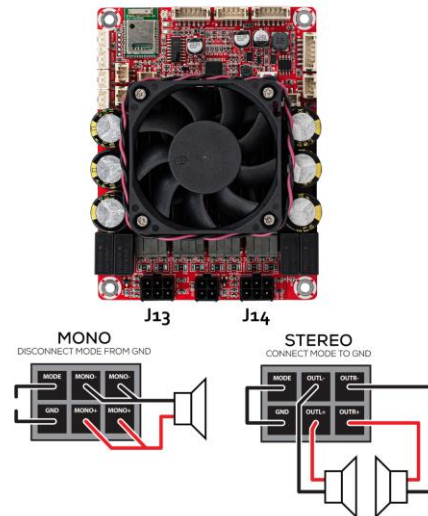

Speaker Output				
J13				
Molex-MiniFit-2x3Pos-3mm				
Pin	Stereo Mode		Mono Mode	
	Function	ADAU1701 Output	Function	ADAU1701 Output
1	MODE2	N/A	MODE2	N/A
2	GND		GND	
3	OUTL2-	DAC2	MONO2-	DAC2
4	OUTL2+		MONO2+	
5	OUTR2-	DAC3	MONO2-	
6	OUTR2+		MONO2+	

Speaker Output				
J14				
Molex-MiniFit-2x3Pos-3mm				
Pin	Stereo Mode		Mono Mode	
	Function	ADAU1701 Output	Function	ADAU1701 Output
1	MODE1	N/A	MODE1	N/A
2	GND		GND	
3	OUTL1-	DAC0	MONO1-	DAC0
4	OUTL1+		MONO1+	
5	OUTR1-	DAC1	MONO1-	
6	OUTR1+		MONO1+	

## 2. Power Connection

Connect a center positive 10-39V DC power supply to J15 using the included wiring harness with pre-attached DC Jack.

Dayton Audio recommends at least 36V 5A power supply, but a 36V 10A power supply is recommended for maximum power.

DC Power (12-36V)	
J15	
Molex-4Pos-3mm	
Pin	Definition
1	GND
2	GND
3	VCC
4	VCC



### 3. Bluetooth Pairing / Disconnect Switch

Attach the included green Bluetooth pairing switch with 2-pin JST connector to J4. If a different switch is desired, simply snip off the green button and solder your own to the 2-pin wiring harness. Only use momentary switches. Do NOT use a latching/toggle switch.

Holding this button down for about a second will allow a new device to be paired to the KABD, and will disconnect the old device. Do not hold this button for longer than 5 seconds. Use this button if you are not seeing “DAKAB” in your Bluetooth list.

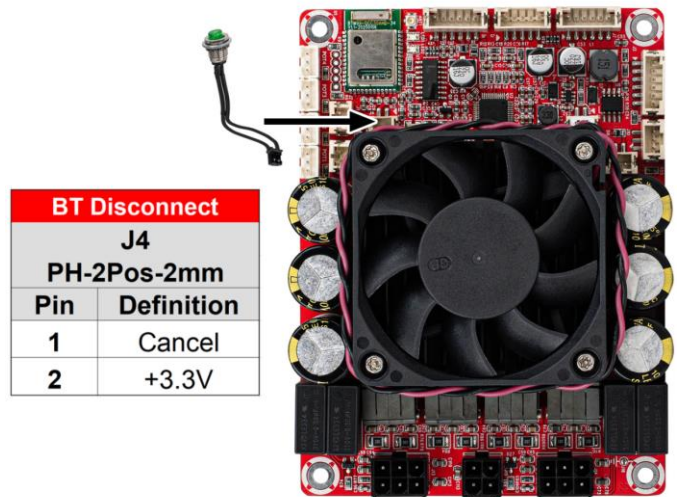

### 4. Bluetooth Connection

Once powered on, the board’s Bluetooth connection will be available on your phone, tablet, laptop, etc and will show as “DAKAB” in your Bluetooth menu. Once connected and music is playing on the source device, audio should begin playing through your connected speakers.

#### Troubleshooting

1. Check that your audio source is functioning correctly and connected to the KABD’s Bluetooth.
2. Check that your speaker connections match the diagram on the underside of the KABD.
3. If you had an ICP programmer attached to the KABD when the KABD was turned on, detach it and reboot your KABD.
  - a. Unpair and repair the KABD Bluetooth connection to your phone or other source device.

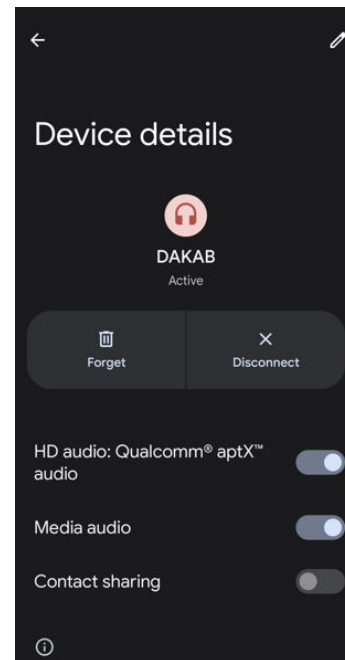



## 5. Signal LED Connection (Optional)

Bluetooth and Signal/Status LEDs found in the functional cable kit can be added to the KABD by plugging them into the corresponding 2-pin connectors on the board. J12 is used for the Signal LED, and J1 for the Bluetooth LED.

The Bluetooth LED will blink while searching for a device, but will be solid when a device is connected.

The Signal LED will be solid when a signal is detected, however the LED will turn off if a signal has not been detected for 5 minutes, and the device will enter a low power standby mode.

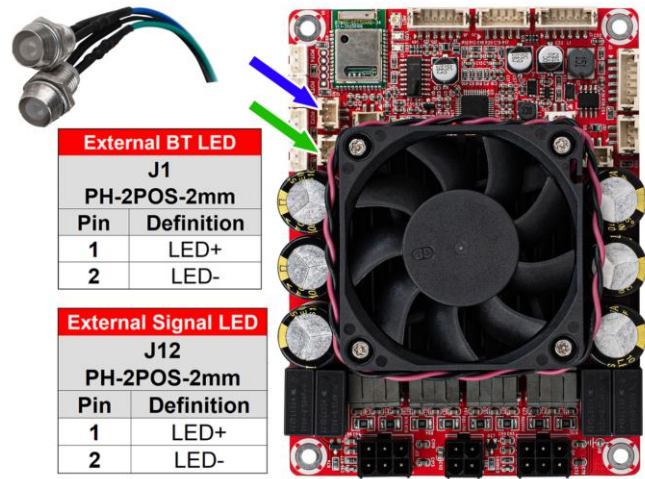

## 6. Input Jack (Optional)

A 3.5mm aux input jack comes included in the functional cable pack, which can be plugged into J5 to function as a line input for external audio sources.

This wiring harness could be modified by snipping off the 3.5mm jack, and soldering stereo RCA jacks to the cables according to the pinout of the AUX IN port.

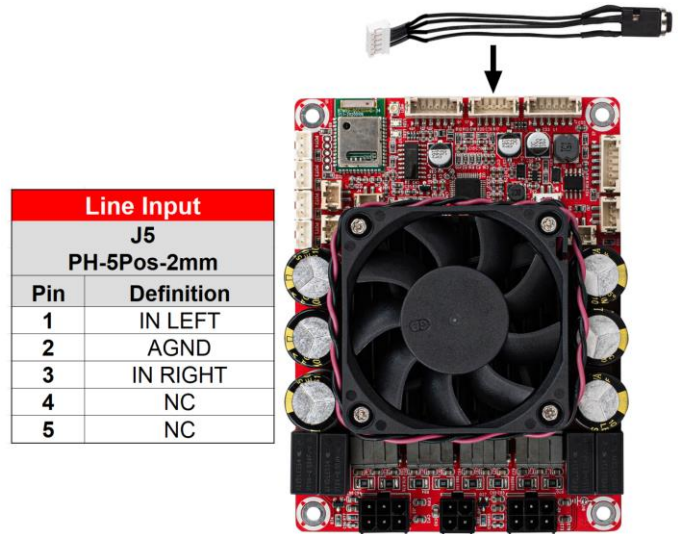

## 7. Standby Switch (Optional)

There is a dedicated 2-pin standby port labelled J11. Any type of latching (toggle) switch can be used here, however included in the functional cable kit is a switch wired to a 2-pin connector that can be used as a standby switch. If this switch is not desired, the switch can be snipped off and the wiring harness can be used for a different style of toggle switch.

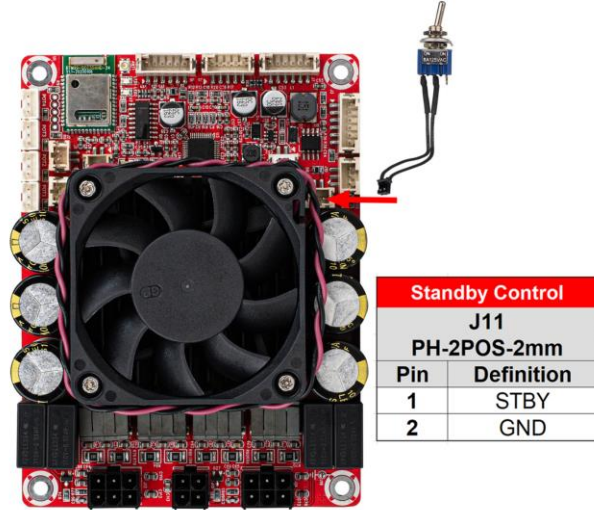

## 8. Potentiometers (Optional)

Attaching the potentiometers found in the functional cable kit (sold separately) to the board in the 3-pin POT1-4 ports can allow quick on-the-fly adjustments, even without any programming. See the potentiometers section for more details. POT1 can immediately be used out of the box as an external volume control.

Numerous SigmaStudio example projects are available to reprogram the potentiometers for custom uses, such as EQ tone controls, high/low pass filters, custom volume controls, etc and can be easily customized.

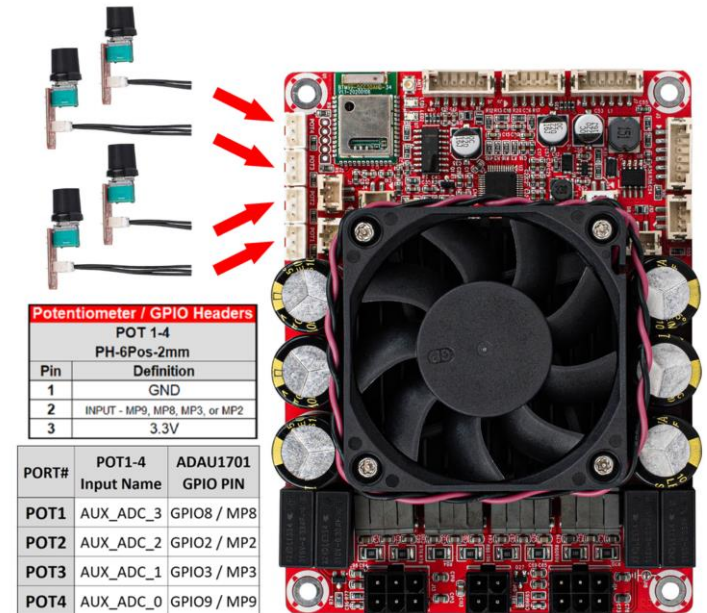

## 9. Bluetooth Antenna (Optional)

(Optional) Attaching the external Bluetooth antenna in the function cable kit can be helpful when the KABD is installed in situations where more range is needed, or if the Bluetooth signal is restricted, such as in a metal case.

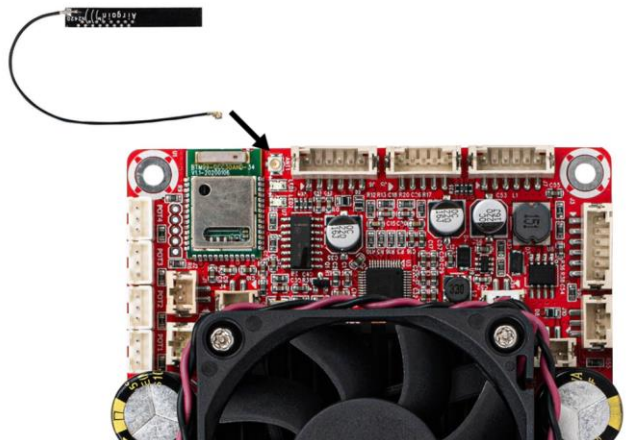

## 11. Programmer Connection (Optional)

Optional but highly recommended, Connecting a compatible programmer (Dayton Audio ICP1 or KPX) will allow you to connect the KABD's DSP chip to your PC, allowing you to create advanced DSP programs. This connection is temporary, and the programmer can be removed when finished. See the "SigmaStudio Connection" section of this document for more details.

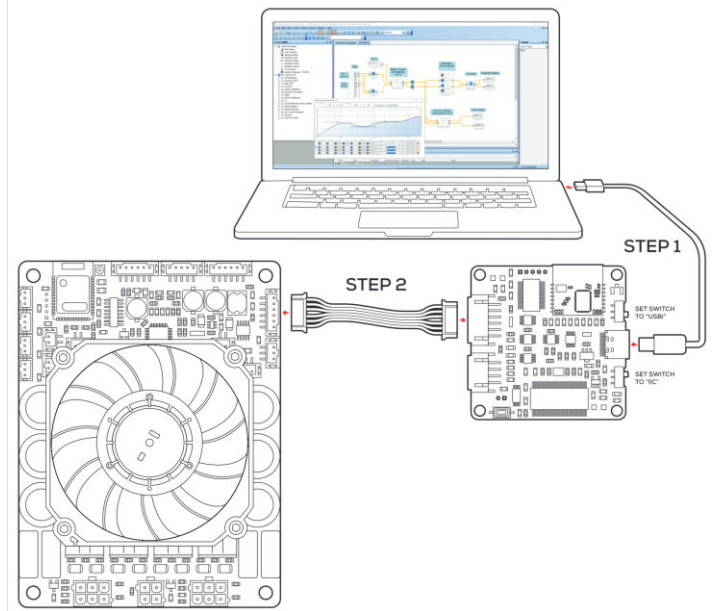

# Potentiometer Headers

POT / GPIO Ports	
POT 1-4 PH-3Pos-2mm	
Pin	Definition
1	GND
2	MP9, MP8, MP3, MP2
3	3.3V

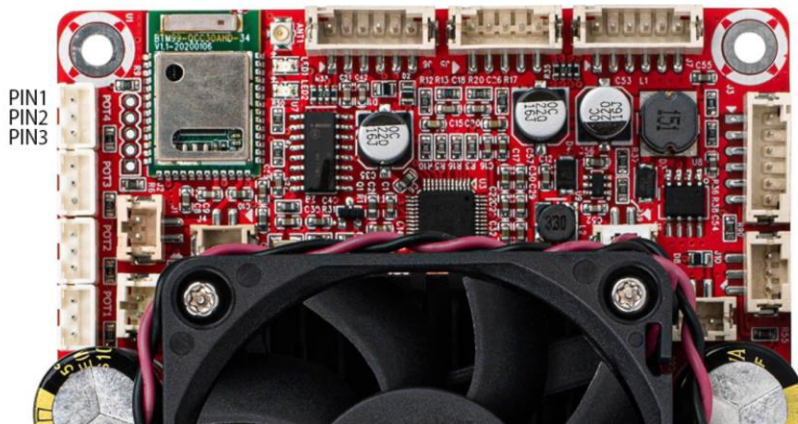

The KABD series of amplifiers come with four headers to make it easy to add external potentiometers, button, switches or rotary encoders to your project. Each of these 3-pin headers expose a voltage supply, GND, and a multipurpose pin of the ADAU1701. The optional cable pack for the KABD series comes with 4 potentiometers with cables that connect directly to these ports, so no soldering is required and they are easy to add to your project. The ports for these potentiometers are 3-pin JST headers and are clearly labelled as POT1-4. The potentiometers in the cable pack are 1k Ohm. Buttons or switches can also be easily attached to these ports and should connect to Pin 1 (GND) and Pin 2 (MP#) as labelled above and the corresponding multipurpose pin must be configured as “Input GPIO Debounce” as seen on the next page.

Out of the box, each KABD amplifier is pre-programmed for the potentiometers to have some basic functions, however there are numerous example projects for most other use cases and can be easily customized with SigmaStudio. A chart of the default potentiometer functions is below.

For instruction on how to use potentiometers or buttons/switches in SigmaStudio projects, see the “SigmaStudio for the KABD series” guide for detailed information.

**Note:** If the potentiometers for making on-the-fly adjustments, the potentiometers **must be left plugged in** for the changes to remain active. For example, if you use POT3 to enable a high pass filter on your speaker outputs, you must leave that potentiometer plugged in for the HPF to remain active. When you remove the potentiometers, the HPF will deactivate. If you do not want to leave the potentiometers plugged in for something like a high pass filter, you need to reprogram the board via SigmaStudio with your custom configuration and do the high pass filter within SigmaStudio.

KABD-4100 Default Firmware Functions			
PORT#	4.0 or 2.0 Mode	2.1 Mode - J13 Bridged	2.1 Mode - J14 Bridged
POT1	J14 Volume (Relative)	CH2 (13) Volume (Relative)	CH2 (13) Volume (Relative)
POT2	J14 High Pass Filter	J14 High Pass Filter	J14 Band Pass Filter
POT3	J13 High Pass Filter	J13 Band Pass Filter	J13 High Pass Filter
POT4	Master Volume	Master Volume	Master Volume

## Potentiometer Port Configuration in SigmaStudio

There is some configuration within SigmaStudio required so the ADAU1701 knows to interpret each multipurpose (MP) pin as a potentiometer input or button/switch input. Simply open the hardware configuration menu, then select the “IC 1 – 170x\140x Register Control” tab. Configure the MP pin that corresponds to your potentiometer header to “Input GPIO Debounce” for a button/switch, or “ADCX” for a potentiometer.

**Any example project from Dayton Audio that you use will already have this preconfigured.**

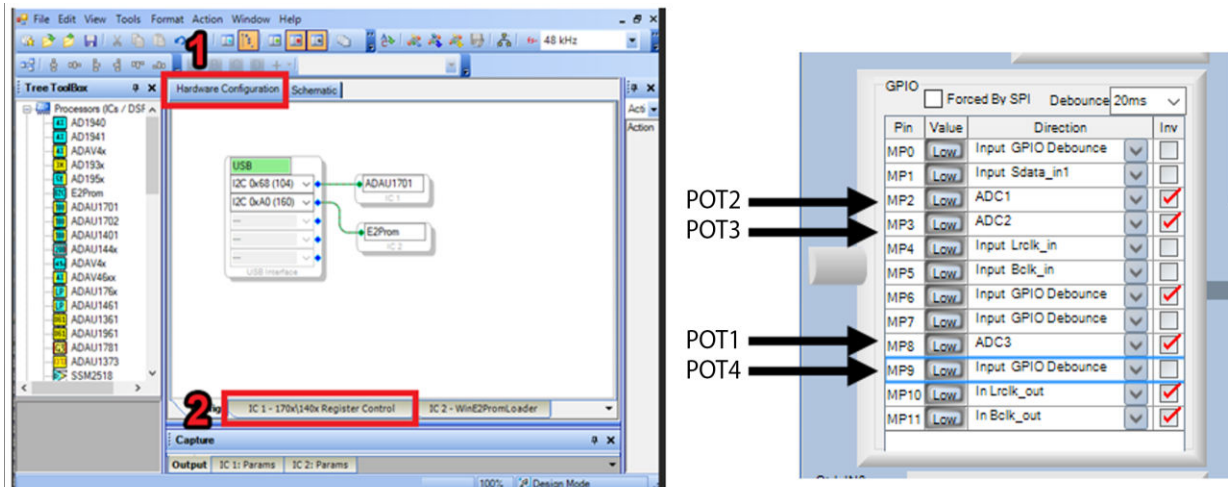

The screenshot shows the SigmaStudio interface. A red box labeled '1' highlights the 'Hardware Configuration' tab. Another red box labeled '2' highlights the 'IC 1 - 170x\140x Register Control' tab. To the right, a GPIO configuration table is shown with arrows pointing to specific rows:

Pin	Value	Direction	Inv
MP0	Low	Input GPIO Debounce	<input type="checkbox"/>
MP1	Low	Input Sdata_in1	<input type="checkbox"/>
MP2	Low	ADC1	<input checked="" type="checkbox"/>
MP3	Low	ADC2	<input checked="" type="checkbox"/>
MP4	Low	Input Lrclk_in	<input type="checkbox"/>
MP5	Low	Input Bclk_in	<input type="checkbox"/>
MP6	Low	Input GPIO Debounce	<input checked="" type="checkbox"/>
MP7	Low	Input GPIO Debounce	<input type="checkbox"/>
MP8	Low	ADC3	<input checked="" type="checkbox"/>
MP9	Low	Input GPIO Debounce	<input type="checkbox"/>
MP10	Low	In Lrclk_out	<input checked="" type="checkbox"/>
MP11	Low	In Bclk_out	<input checked="" type="checkbox"/>

Arrows point from the table to labels: POT2 and POT3 point to MP2 and MP3; POT1 and POT4 point to MP9 and MP10.

“ADC” is for Potentiometers  
“Input GPIO Debounce” is for switches

## Using the Potentiometer Ports for Connecting Buttons or Switches

The 4 potentiometer ports on the boards are optimized for potentiometers, however they can be easily used to instead connect buttons or switches to the ADAU1701, as they expose 4 of the multipurpose pins of the ADAU1701. Simply connect your switch to the GND and MP pin of the desired potentiometer port (Pin 1 and Pin 2 on the diagram below). Even though these are 3 pin headers, the 2-pin connector that comes attached to the LEDs, Bluetooth pairing button, etc will also fit, just not perfectly. There is a switch that comes in the optional KABD cable pack pre-wired to a 2-pin connector. The MP Pin must be set to “Input GPIO Debounce” in the register configuration like above to work as a button/switch.

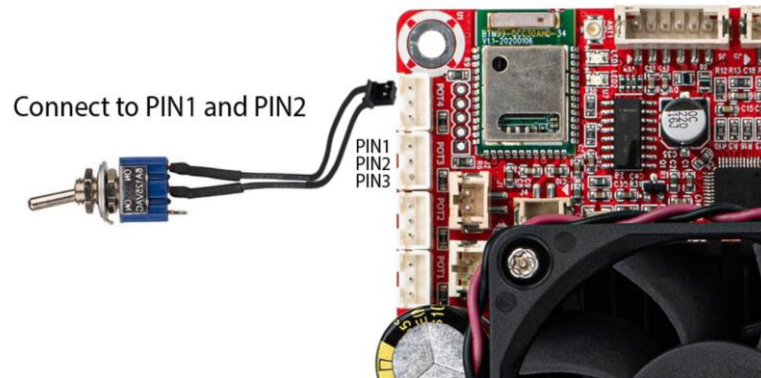

# Sigma Studio Connection - Quick Start

A DSPB-ICP1 or KPX (USBi) programmer board is required to program the ADAU1701 DSP chip on KABD amplifiers. The programmer can be thought as the bridge between the DSP chip and the computer. The programming board translates instructions from the computer controlling SigmaStudio into a signal that the KABD's ADAU1701 can understand. The programmer only needs to be connected while the device is being programmed. After programming, it can be removed and used to program as many other KABD amplifier boards as needed.

Note that a comprehensive SigmaStudio guide for the whole KABD series is available wherever you found this document (the product page for the KABD-4100) this section is merely to get you started in SigmaStudio, for detailed usage read that guide which is intended as a learning document that goes over all details needed to make custom projects such as input routing, output routing, bass algorithms, PEQ, controllable filters with potentiometers, presets switchable with a toggle switch, etc.

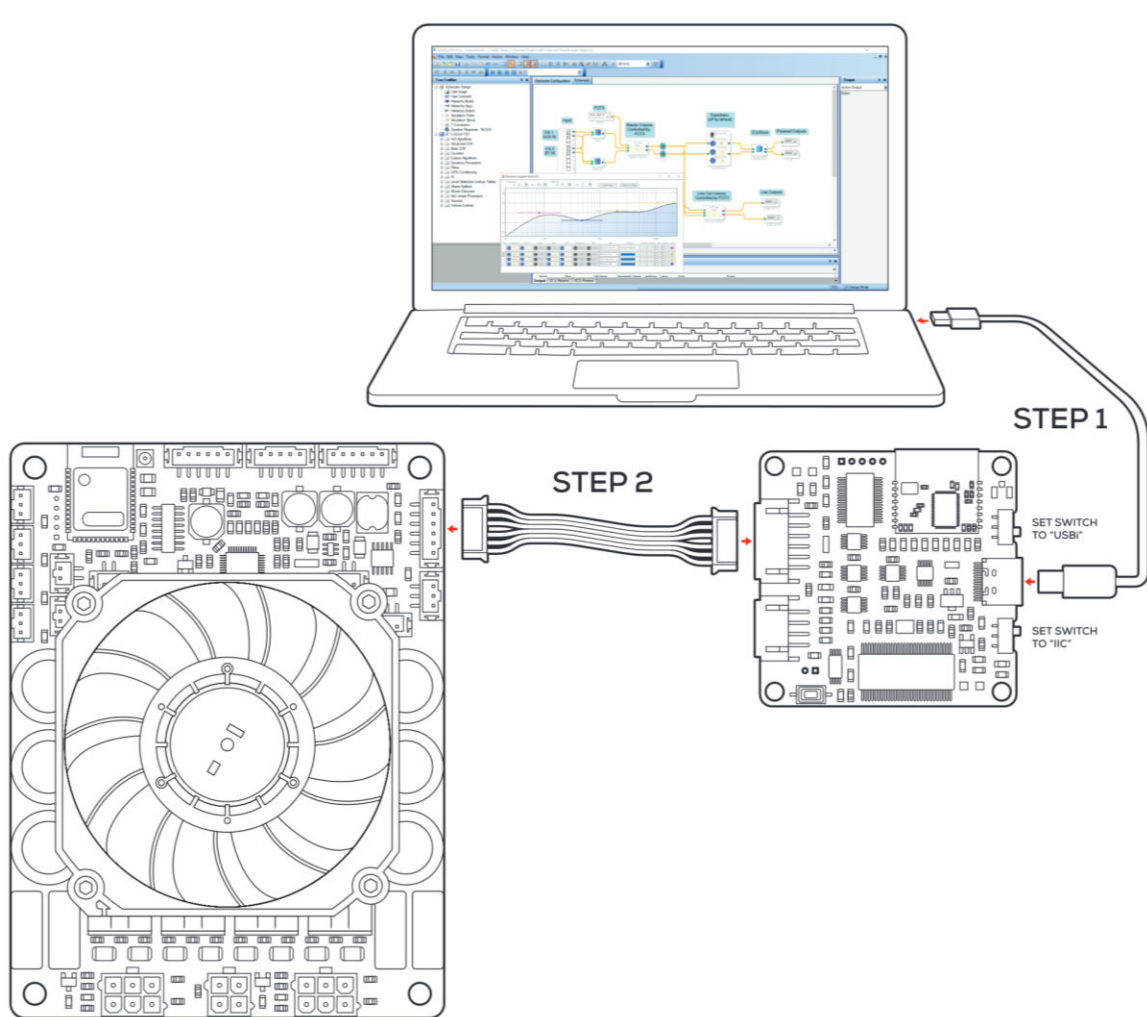

*The graphic above demonstrates using a KPX Programmer to connect the KABD-4100 to a laptop, however an ICP1 programmer will also work.*

The following steps make it easy to connect your programmer to the SigmaStudio development tool, and then your programmer to your KABD amplifier. The steps require a basic knowledge of computer operation, but if the steps are followed closely, it is not too complicated. Please complete these steps in this order for consistent connection.

**Note:** Sigma Studio connection **requires a Windows PC and an ICP1 or KPX programming board.**

## Steps

1. [Download and install the most recent version of SigmaStudio to your system for free.](#)
2. Make sure your ICP1 or KPX is disconnected from USB and from your KABD amplifier before starting, to ensure the proper steps are taken.
3. Open an example project from downloadable from the Parts Express product page for the KABD-4100
4. If starting a project from scratch (not recommended), open a new project in SigmaStudio by pressing File->New Project. We recommend using an example project and modifying it for your needs at least for the first time you re-program a KABD amplifier to make sure everything is working correctly.
5. Ensure that your ICP1 or KPX is **not** yet connected to the KABD. Set the switches on your ICP1 or KPX appropriately for programming the KABD.
  - a. **KPX** – Set the switches on your KPX are set to “USBi” and “IIC” for proper programming with the KABD.
  - b. **ICP1** – Set the only switch on your ICP1 to “PROGRAM” mode
6. Plug a micro USB cable (ICP1) or USB C cable (KPX) into the PC running SigmaStudio, and then connect that USB cable to your programmer
  7. If all is correct, you will see the USB block turn green, like below.

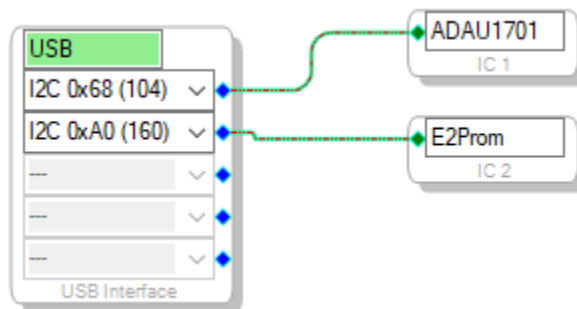

- a. Note that this block turning green means that SigmaStudio recognizes your programmer, **it does not indicate that SigmaStudio can communicate with your KABD amplifier yet.**
- b. If the connection is not successful (the block stays orange),
  - i. Disconnect all cables from the KPX / ICP1 (6-pin cable, 4-pin cable), and then plug in the USB cable to the KPX / ICP1.
  - ii. it is important to try a different USB cable, even if you think it's a 'good cable'. Many USB cables endure a lot of abuse from charging devices, and although they might still provide power, they might have issues transferring data. Some





## Default Register Configuration in SigmaStudio

These are the default KABD-4100 register settings. It is setup for proper I2S settings for Bluetooth Input (Master Mode) and or I2S input (Slave Mode) and I2S output. It also sets up the POT ports for potentiometers (if attaching switches to these ports instead, see the section about switches).

If using an example project for the KABD, this will already be configured for you. If upgrading a DSPB project or creating a project from scratch, make sure your register settings match the screen below. If unsure, modify an example project to suit your project's needs rather than starting from scratch.

The screenshot displays the Hardware Configuration window in SigmaStudio, showing the Schematic view of the DSP Core. Key configuration areas are highlighted with yellow boxes:

- Serial Input (I2S):** Shows LRCLK polarity (Left) and BCLK data change (Left).
- Serial Output 1 (channels 0-7):** Shows Master Mode checked, LRCLK polarity (Left), BCLK polarity (Left), Frame Sync Type (LRCLK), Frame Sync Freq (internal clock/1), MSB Position (delay by 1), Word length (24 bits), and BCLK Frequency (internal clock/1).
- GPIO:** A table of pin configurations is shown, with MP1 through MP11 highlighted. MP2, MP3, MP8, and MP9 are specifically noted as potentiometer ports.

Register	Address	Value
Core	2076	b 00000000011100
GpioAll	2056	b 000000000000
SerialOut1	2078	b 01100000000000
SerialInput	2079	b 000000
MpCfg0	2080	b 010001001111111101000000
MpCfg1	2081	b 110011001111111100001100
AnalogPower	2082	b 000000000000
AnalogInterfa	2084	b 1000000000000000
AnalogInterfa	2085	b 0000000000000000

MP2, MP3, MP8 and MP9 are for potentiometers.

## Writing to E2Prom – Burning Custom SigmaStudio Programs to Non-Volatile Memory with SigmaStudio

This step writes your custom program to non-volatile memory on the KABD amplifier. This means that the program will be retained on the KABD even after it has been turned off and then back on again. This can be reprogrammed as many times as needed. When you are programming via SigmaStudio and making changes on the fly, the program is only stored in TEMPORARY memory. It is not until you write the program to E2Prom that your custom program can be reprogrammed to the DSP as the board turns on. **If you find that your custom program is lost on a power cycle, it means you have not written the program to E2Prom.**

**IMPORTANT – This step will erase the stock configuration of the board! This means that the default functions of POT1-4 will be reprogrammed or removed, depending on the custom SigmaStudio project that is burned.** See the project pack for original firmware for the KABD-4100.

1. This guide assumes that you have successfully re-programmed your board with a custom program using the 'link compile download' button , and you are ready to burn it to the E2Prom memory (it can be rewritten as many times as desired).
2. Right click your "ADAU1701" block and click "Write Latest Compilation to E2PROM". This means it will burn the latest program you have compiled to E2Prom. This means the program that was configured the last time you pressed "Link Compile Download" or just "Link Compile Connect". If this option is greyed out, it means you need to press Link Compile Download and run a program on your KABD first.

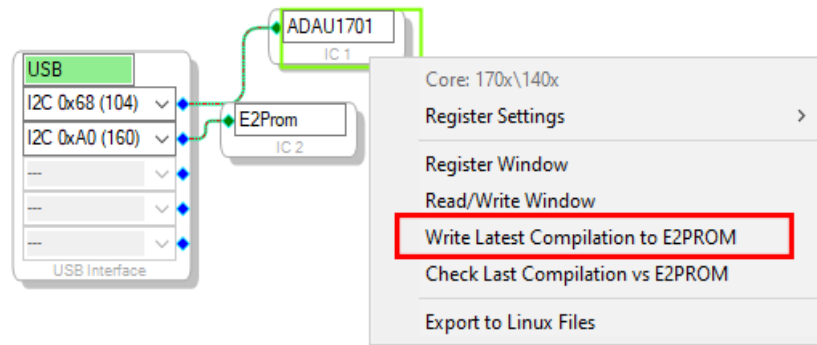

3. In the window that opens, make sure the settings match what is in the screenshot below (they are the default settings), and press OK.
  - a. NOTE: Your programmer's switch(es) need to be set properly for this step to work.
    - i. The ICP1 switch's position must be set to "PROGRAM"
    - ii. The KPX's switches must be set to "USBi" and "IIC".

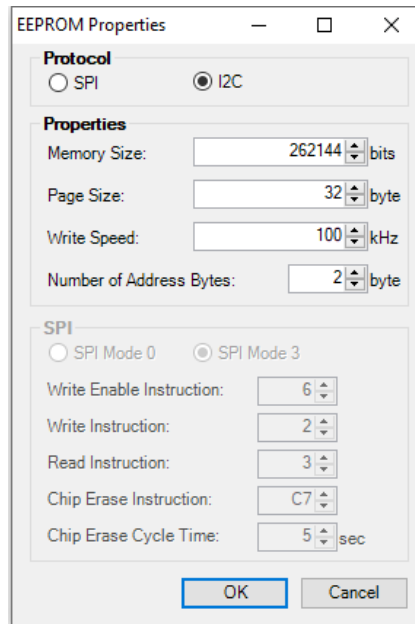

4. The program should now be written to E2PROM after it finishes programming. This means you can remove your programmer from the KABD, and your program should remain programmed on the board after power cycling the KABD.

# Cascading 2 KABD-4100 Amps for up to 8 Channels

The thoughtful design of the KABD-4100 means it is easy to cascade 2 of these amps together for up to 8 channels of discrete powered output with individual DSP on every single channel. This makes even the most complicated audio systems easy to turn into a reality. Perhaps it is a pair of 3-way speakers utilizing a bridged channel to pump extra power into the (sub)woofer, a pair of 3-way speakers with an extra driver in the back DSP'd to control the speaker's directivity, a complicated line array system, or really anything you can imagine. Like in other configurations, each amp can be configured in 4.0, 2.1, or 2.0 mode, which gives ultimately flexibility.

This system works by configuring one KABD-4100 as the master device, and one KABD-4100 as the slave device. The clock signals of the master KABD-4100 are shared with the slave KABD-4100, which allows a full quality, digital I2S audio signal to be passed from the master to the slave device with effectively immediate transmission. **Note:** *Due to the sensitivity of I2S audio signals, the master and slave KABD-4100 must be placed very close together, for example they will always need to be in the same cabinet. They cannot be separated beyond the length of the 6-pin to 6-pin cable that comes in the KABD-SPF cable pack.*

We recommend going through the quick start guide of this manual with a single KABD-4100 before trying to cascade them to ensure familiarity with the amplifier.

There are example SigmaStudio projects for creating a pair of Stereo active 3-way speakers using cascaded KABD-4100 amplifiers. One project is intended for the master (left) channel speaker, and one is for the slave (right) channel speaker. Any of the other KABD-4100 projects can be used in cascaded mode as well, but the stereo 3-way speaker projects are made specifically for this purpose.

## You will need

- 1) 2 x Dayton Audio KABD-4100 amplifiers with all included cables
- 2) 1 x Dayton Audio KABD-SPF cable pack
  - a. 6-pin to 6-pin cable (for i2S connection)
  - b. 3-pin to 3-pin cable (for mute/standby control syncing)
- 3) All desired speakers / drivers attached appropriately to the KABD-4100 speaker wiring harnesses
- 4) Power Supply solution for powering both amplifiers
- 5) (Optional) 1 x USBi Programmer - Dayton Audio ICP1 or Dayton Audio KPX
  - a. It is technically optional, but highly recommend to reprogram the KABD-4100 amplifiers with SigmaStudio in this mode to maximize your project's potential.

## Steps

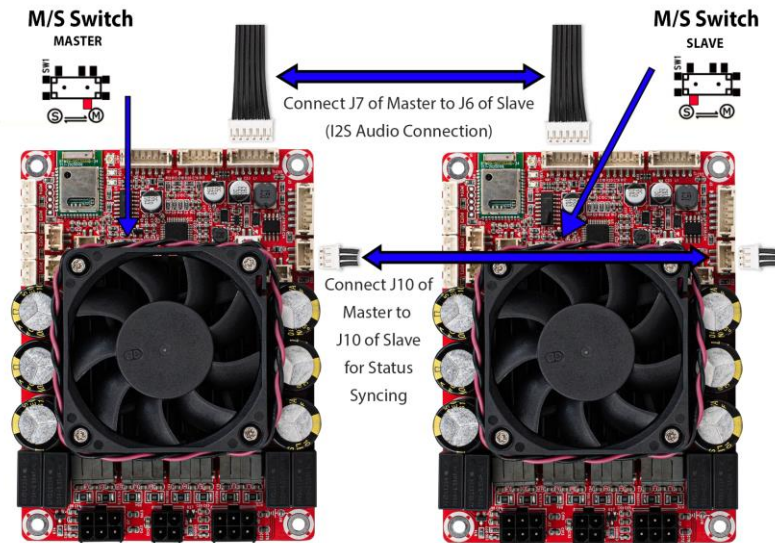

- 1) Set the M/S switch accordingly on your 2 KABD-4100 amplifiers. One needs to be master; one needs to be slave.

Mode (SW1)	Bluetooth In	I2S Input	I2S Output
Master (M)	Enabled	Disabled	Enabled
Slave (S)	Disabled	Enabled	Enabled

- 2) Connect J7 (I2S Output) of your master KABD-4100 to J6 (I2S Input) of your slave KABD-4100. This must be completed using the 6-pin to 6-pin cable that comes in the KABD-SPF pack.
  - a. This connection is very sensitive due to the nature of I2S data communication. The wires of the 6-pin cable **must not overlap/cross**, which is why a special 6-pin to 6-pin cable is included in the KABD-SPF cable pack, which has the wires adhered together to prevent overlapping. If you, for example, used the 6-pin cable that comes with your programmer, the data transmission will not be correct because of the potential of the wires to overlap. If you use the wrong cable, you will know it.



- 3) Connect the synchronization ports J10 on both amplifiers together using the 3-pin cable included in the KABD-SPF cable pack. This connection will sync the mute/standby functions of the boards together, which will prevent otherwise strange behaviour (pops, clicks) if this connection is not made.

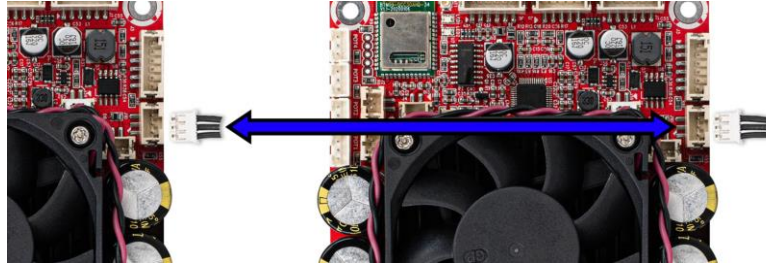

- 4) Connect your desired speakers/drivers to the KABD-4100 according to earlier sections of this documents.
- 5) Connect your power supply to the KABD-4100. We recommend at least a 36V 10A power supply for this configuration, but you will need a higher wattage power supply for max power.
- 6) Once you have made all of the previous connections, set the M/S switches correctly, and connect to Bluetooth of your master KABD-4100, you should find that cascading is now working. If it is not working, re-read this guide and check all connections. If you have reprogrammed your master KABD-4100 away from stock settings, that is likely why it is not working. See the next section for using SigmaStudio while in this cascaded mode.

### Using SigmaStudio while in KABD-4100 Cascaded mode

Although it is not required for other projects, for cascading to work, your custom SigmaStudio program must output to DIG0 and DIG1. DIG0 and DIG1 represent the I2S audio that is output via J7 (I2S Output Jack). Without this in your program for your master KABD-4100, cascading will not work because there would not be an I2S output signal to send to your slave KABD-4100. It is not required in your slave KABD-4100's custom program, but it does not hurt anything to leave it in there, because all of the example KABD-4100 projects have I2S Output already set up.

Below is the minimum project required for cascading to work on the master KABD-4100. In this very basic project we simply combine the Bluetooth and AUX Input signals, then split them to send all signals to the powered outputs of our master device (J14 ad J13) and also to the I2S Output (J7). In a typical program, there will be many DSP blocks between the input and outputs. This is just a simple example to demonstrate the require outputs. If you have any of your outputs in bridged mode, you might forgo adding DAC1 or DAC3 outputs.

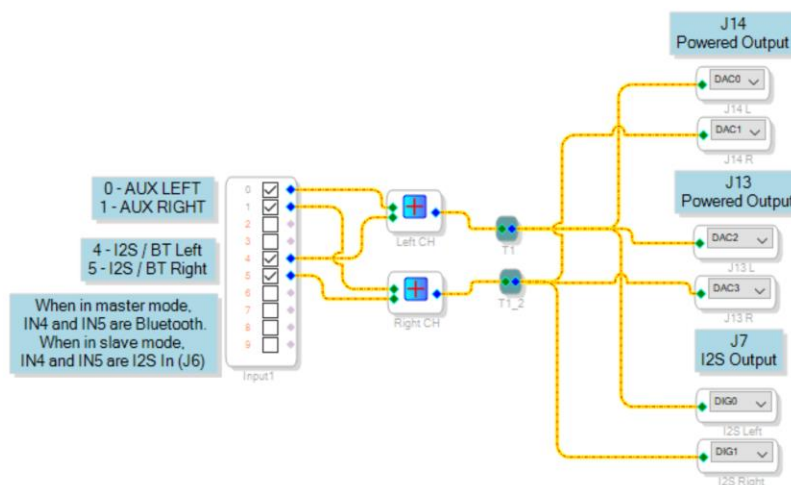

## Cascaded KABD-4100 Troubleshooting

Q: Audio is working with my master device, but no audio is transmitted to my slave device.

- 1) Check register configuration. Make sure it matches the screenshot above. If these settings are not correct, the I2S input might not be working on your slave KABD-4100, or the I2S output of your master KABD-4100 might not be working.
- 2) Make sure you are routing audio to DIG0 and DIG1.
- 3) Try the KABD-4100 example projects instead of your own custom program. If this does not work, you know the problem is with the hardware setup. If it does work, you know the problem is in your custom program.
- 4) Ensure there is not a potentiometer programmed for volume that is turned down too low.

Q: I am getting popping and crackling sounds on my slave KABD-4100s output.

- 1) This is most likely from the I2S connection wire. Make sure you are using the 6-pin cable that comes in the KABD-SPF cable pack, as it ensures that the wires will not overlap. If you are still having problems, make sure that the cable is in good condition and also is secure and will not move around during use. Also make sure no other cables are touching this wire.

Q: How do I do this if my amplifiers cannot be close together?

- 1) Dayton Audio cannot officially support any configurations for cascading unless the amplifiers are close together, within the range of the 6-pin cable included in the KABD-SPF cable pack. Although it might be possible to make it work otherwise, it is not supported.

# Example Projects Types for the KABD-4100

The KABD-4100 is an extremely capable amplifier, and there is no limit to the kind of projects that can be achieved with it. Download the SigmaStudio programming guide for the KABD series and the project pack found on the product page of the KABD-4100 for details about how the necessary DSP programming can be achieved to achieve these projects.

## 2.1 Systems

Creating a 2.1 system (A stereo pair of speakers, plus a subwoofer) fully powered by the KABD-4100 is as easy as using one of the output jacks in stereo mode (to power your speakers) and using the other speaker output in bridged/mono mode to power your passive subwoofer. By building the KABD-4100 into your subwoofer, this could clear up much needed room on your desk, TV stand, etc.

### Example Projects :

*"2.1 Project with Preset Switching via GPIO Switch.dspproj"*

*"2.1 Speaker Project with Potentiometer Tone Controls.dspproj"*

*"Simple 2.1 Project.dspproj"*

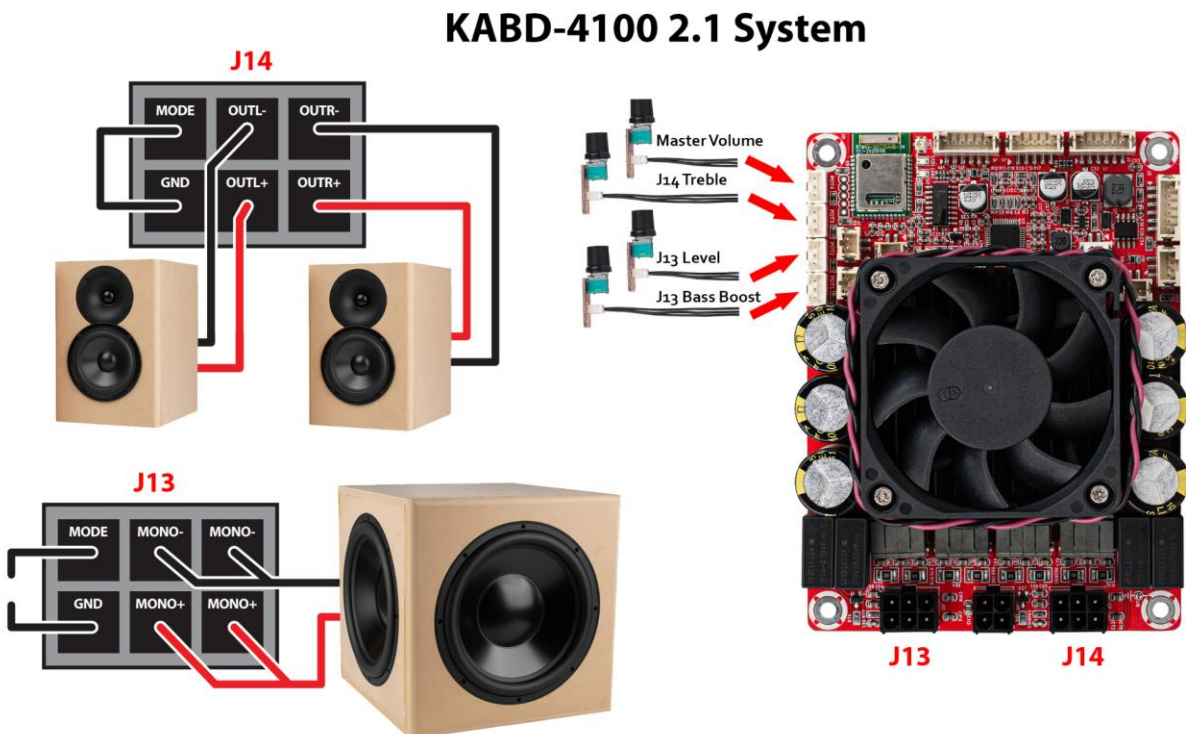



## Active 2-Way Monitors, Bookshelf Speakers, Tower Speakers, etc

With a 4 channel KABD amplifier, making a pair of completely custom 2-way speakers has never been easier. 4 channels mean complete DSP control and power for each woofer and tweeter in a 2-way design. The power of DSP means there is no need to build multiple iterations of crossovers to get the sound exactly how you want it. Simply keep configuring DSP settings such as crossover filters, EQ phase adjustment and more until you have the perfect sound.

### Example Projects :

*“Simple Stereo 2-Way Speaker Project.dspproj”*

*“Stereo 2-Way Speaker Project with Potentiometer Tone Controls .dspproj”*

*“Stereo 2-Way Speaker Project with Preset Switching via GPIO Switch.dspproj”*

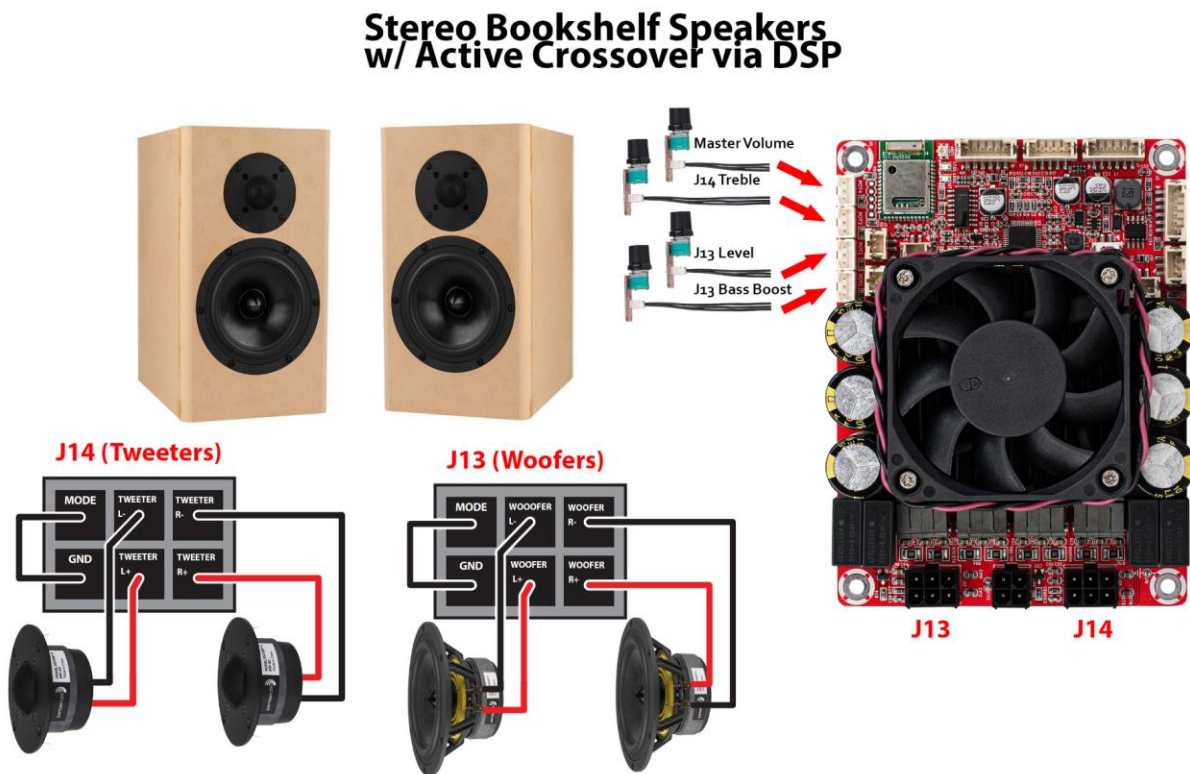

## Mono 3-Way Speaker

Using a similar configuration as a 2.1 system, the KABD-4100 could also be used to create a mono 3-way speaker. Simply use one output in stereo mode to power your tweeter and midwoofer, then use the second output in bridged mode to power your woofer. Within SigmaStudio, the stereo audio signal can be mixed to mono and a 3-way crossover block can be used. The example project also has optional volume controls to control tweeter and woofer levels with separate potentiometers, but these can of course be removed if not desired.

**Example Project** – *“Mono 3-Way Speaker Project”*

## Stereo Pair of active 3-Way Towers By Cascading 2 KABD-4100 Amps

A feature unique to the KABD-4100 is that 2 of them can be cascaded together with I2S audio for up to 8 channels of output with discrete DSP on each channel, however even in cascaded mode, each KABD-4100 can be configured in 4.0, 2.1, or 2.0 mode, which offers numerous combinations not only in number of channels but also in output power. For example, by cascading 2 KABD-4100 amps together and configuring both of them into 2.1 mode, you can make a stereo pair of tower speakers with 100 Watts going to each tweeter and woofer, then 200 Watts for each (sub)woofer.

There are a set of example SigmaStudio projects to achieve this, that have slightly different settings but can be easily customized.

**Example Projects :**

*Master - “Stereo 3-Way Speaker via Cascaded KABD-4100 (MASTER LEFT CHANNEL).dspproj”*

*Slave - “Stereo 3-Way Speaker via Cascaded KABD-4100 (SLAVE RIGHT CHANNEL).dspproj”*

## Customized, High Power Amplifier

It is possible to create a completely customized, high power 4CH, 2.1CH, or even 2.0CH DSP amplifier with the KABD-4100. For example, you might create a customized case that will house the KABD-4100 and a very high-power DC supply, such as 36V 10A. You can then add all of the ins/outs of the KABD-4100 to this case, such as binding posts for speakers, RCA jacks for input, and up to 4 potentiometers to control various functions.

What makes the KABD-4100 uniquely suited for this task is not only the high power, programmable DSP and high-quality Bluetooth streaming, but the ports for external potentiometers that can be completely customized for a large range of functions. For example, you might add a master volume control, an 0.1 subwoofer volume control, a custom bass boost filter, treble control, midrange control, balance control, or nearly any other filter you can think of.

**Example Project :** Nearly all/any of the project examples could be used for this type of project. It depends on what style of amplifier you want.

# Example SigmaStudio Projects

On the product page for the KABD-4100, you will find a zip file that contains numerous project examples for the entire KABD series, many of which are referenced throughout this manual. There is a folder in the zip for projects that specifically apply to the KABD-4100. For further descriptions of the projects, see the end of ( but read all of ) the “SigmaStudio Programming Guide for the KABD Series of Amplifiers” Guide. You will find pre-configured and easily modifiable projects with features such as bass enhancement, on-the-fly tone control with potentiometers, on-the-fly preset switching, 2-way speaker projects, 3-way projects and so much more.

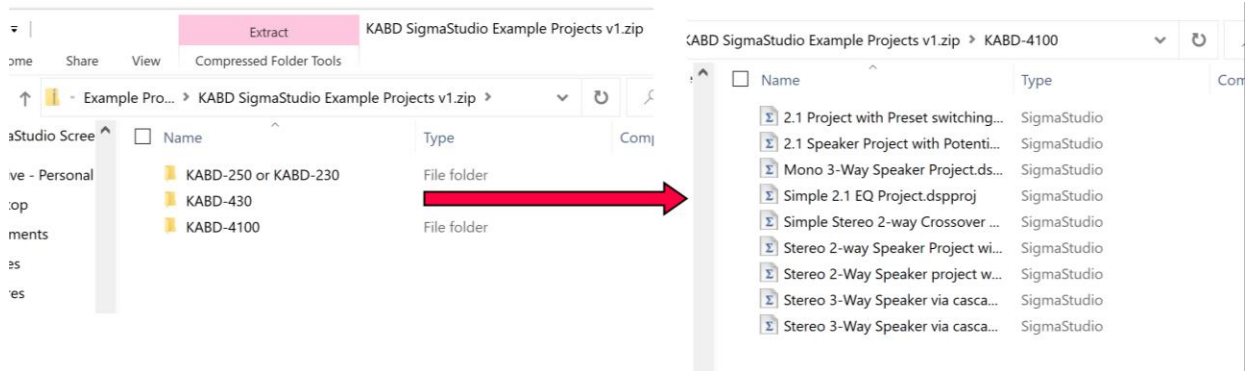

# SigmaStudio Programming Guide

On the product page for the KABD-4100, you will find a PDF file that is an extensive SigmaStudio guide tailored specifically for the KABD Series of amplifiers. This guide goes over usage of every DSP block used in the example projects, as well as going over most of the example projects themselves. Although the example projects are easy to modify and use for your purposes without understanding the entire DSP chain, the SigmaStudio programming guide serves as a resource for understanding every detail of the DSP projects, and can also be a good learning guide for learning DSP via SigmaStudio in general.

Below is an example, annotated SigmaStudio program for the KABD-250 or KABD-230.

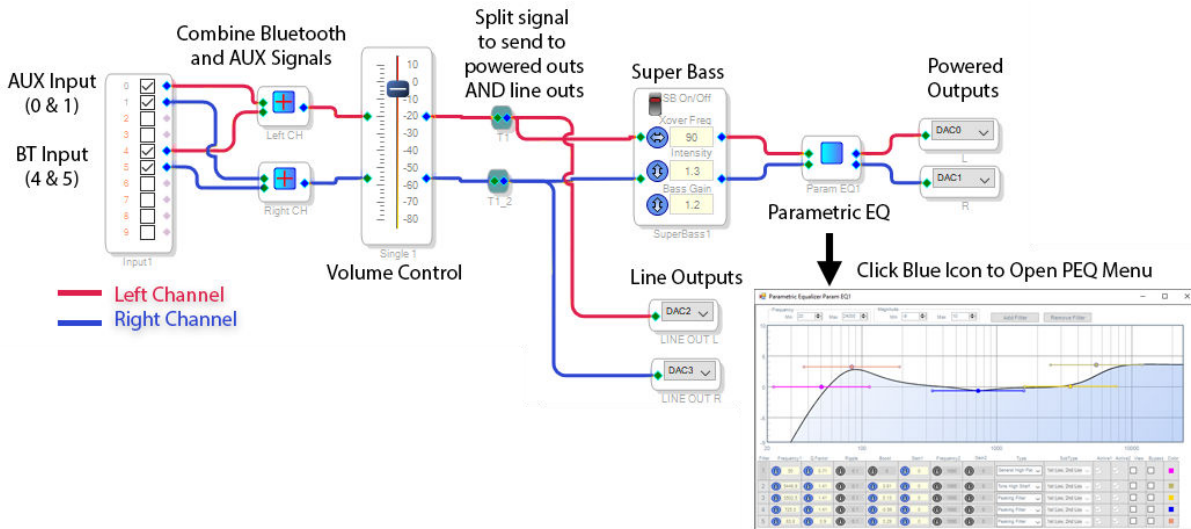

# Specifications

## Dimensions

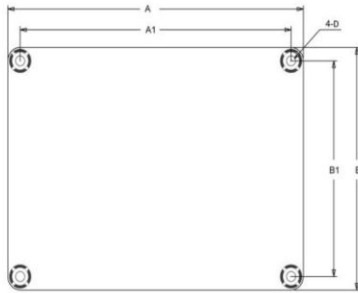

Dimensions	A (inch/mm)	A1 (inch/mm)	B (inch/mm)	B1 (inch/mm)	D (inch/mm)
	4.80/121.92	4.40/111.76	3.60/91.44	3.20/81.28	0.15/3.8

### Notes:

- All dimensions are typical in inches/mm
- Tolerance x.xx =  $\pm 0.02(\pm 0.50)$

## Electrical Specifications

Parameter		Conditions	Min.	Typ.	Max.	Units
Number of Channels		-	-	4	-	-
Minimum Load Impedance		-	-	4	-	$\Omega$
Efficiency		4 x 100W@6Ohm, 1kHz	-	89.5	-	%
Nominal Power Requirement		@36V, 1kHz	-	100	-	W
Operating Voltage		@1kHz, 6Ohm	10	36	39	V
Idle Power		Signal detected	-	9.2	-	W
		No Signal detected	-	360	-	mW
Switching Frequency		SD Floating@36V	-	400	-	kHz
Power Consumption		1/4 of max output power@6Ohm, 24V, 1kHz	-	34	-	W
		1/8 of max output power@6Ohm, 24V, 1kHz	-	18	-	W
Control	Standby (Low = inputs enabled)	High-level Input Voltage	3.3	-	-	V
		Low-level Input Voltage	-	-	0.8	V
	Mute (High = outputs enabled)	High-level Output Voltage	3.3	-	-	V
		Low-level Output Voltage	-	-	0.8	V
Standby Power		SD short to GND, only when low power module available	-	97	-	mW

## Audio Specifications

Parameter		Conditions	Min.	Typ.	Max.	Units
Amp Gain		@6Ohm, 20Hz - 20kHz	-	26	-	dB
DSP Gain	SE1 (Single Amp)	@6Ohm, 1kHz	-60	-	0	DSP Gain
	SE2 (Line Output)	@6Ohm, 1kHz	-60	-	6.5	dB
Input Sensitivity		2 x 50W@4Ohm, 1kHz, 23.5dB	-	770	-	mV
Filter Gain		Butterworth, Q= 0.707	-	4	-	dB
Cutoff Frequency		HFP	0.25	-	2	kHz
		LFP	-	20	-	kHz
SNR		2 x 50W@6Ohm, THD+N=1%, 26dB, A-weighting	-	97	-	dB
THD+N		5W@6Ohm, 1kHz, 26dB	-	0.04	-	%
		10W@6Ohm, 1kHz, 26dB	-	0.07	-	%
Input Impedance		-	-	10	-	k $\Omega$
Supported Sampling Rates		-	-	48	-	kHz
Output Noise Level		A-weighting, Input Connected to GND, 25.8dB	-	200	-	$\mu$ V
DC Offset		-	-	10	-	mV
Crosstalk Separation		20Hz-20kHz, Gain=26dB	-	-60	-	dB

# Version History

V1.0 (2/9/2022) – Initial Release of the KABD-4100 user manual.

Launched at the same time as:

- the SigmaStudio guide for the KABD Series v1.0. PDF
- KABD Series SigmaStudio Example Projects v1.0.ZIP