

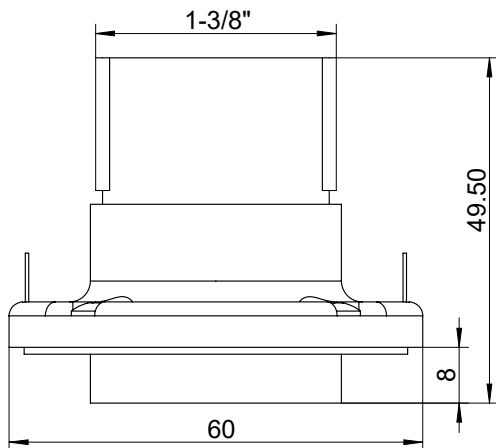

# 40W PEI Super Tweeter

## PRO Neo-8

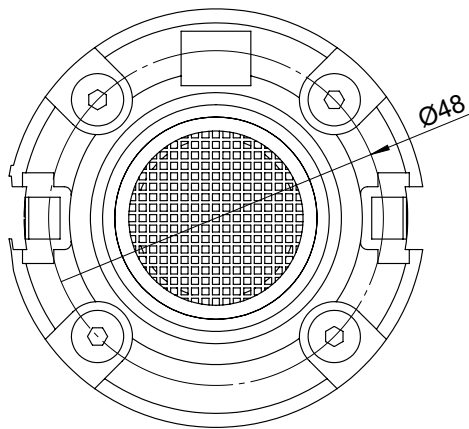

### PARAMETERS

Impedance	8 ohms
Re	5.96 ohms
Le	0.185 mH @ 10kHz
Fs	1,860 Hz
Qms	N/A
Qes	N/A
Qts	N/A
Mms	N/A
Cms	N/A
Sd	N/A
Vd	N/A
BL	N/A
Vas	N/A
Xmax	N/A
VC Diameter	25.4 mm
SPL	105 dB @ 2.83V/1m
RMS Power Handling	40 watts
Usable Frequency Range	2,500 – 20,000 Hz
Recommended Crossover	3.5kHz

### FEATURES

- High sensitivity provides plenty of output for pro-audio use
- Great replacement value for popular PA cabinets
- Standard 1-3/8" 18TPI throat is compatible with any screw-on horn
- Low-profile fits in even the most compact cabinets
- Forgiving frequency response and impedance makes crossover design simple

### IMPEDANCE/PHASE

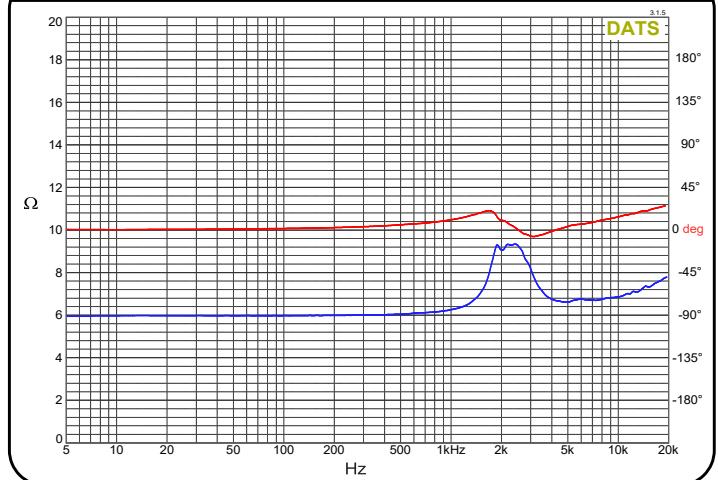

### FREQUENCY RESPONSE

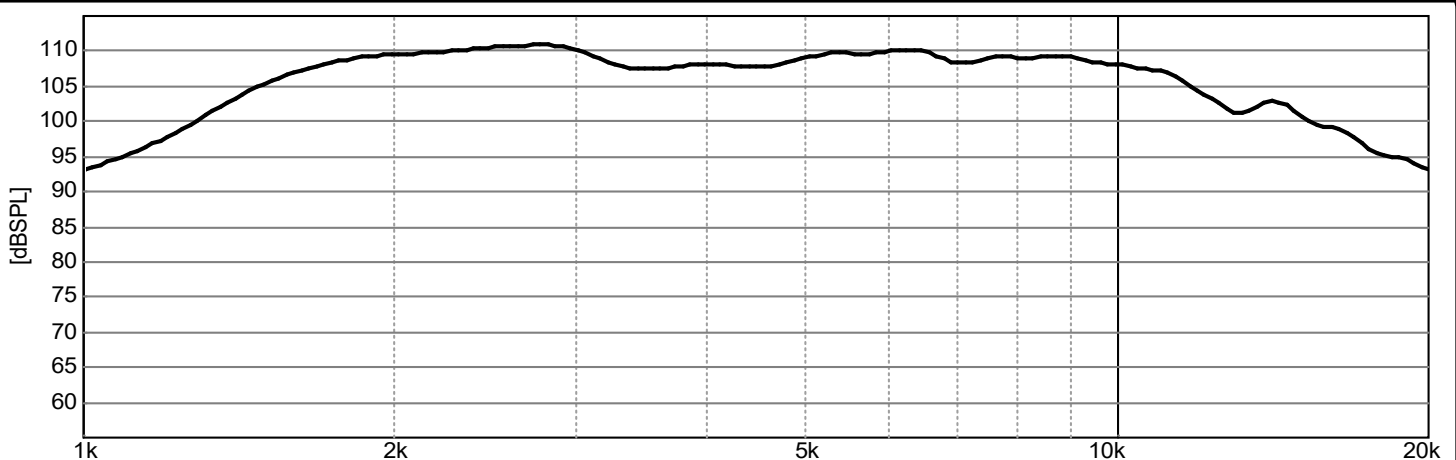

OmniMic

Frequency Response -freq [Hz]

Black = 0° (without capacitor)

Note: 1/12th octave smoothing

Installed on Dayton Audio H812 Horn