

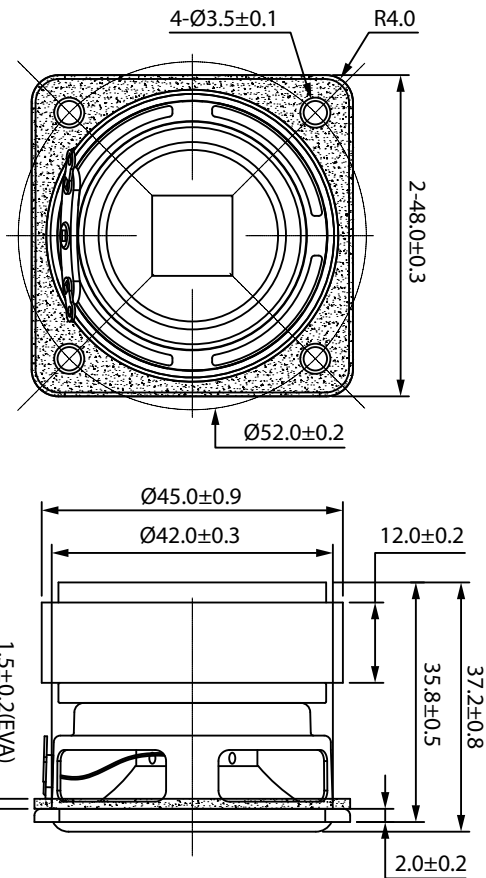

2" Full-Range 5W 4 ohm

CE48-4



PARAMETERS

Impedance	4 ohms
Re	3.5 ohms
Le	0.37 mH @ 1kHz
Fs	151 Hz
Qms	11.03
Qes	1.04
Qts	0.95
Mms	1.9 g
Cms	0.59 mm/N
Sd	9.1 cm ²
Vd	1.09 cm ³
BL	2.48 Tm
Vas	0.068 liters
Xmax	1.2 mm
VC Diameter	16 mm
SPL	79 dB @ 2.83V/1m
RMS Power Handling (AES 426B)	5 watts
Usable Frequency Range (Hz)	120 - 20,000 Hz

IMPEDANCE/PHASE

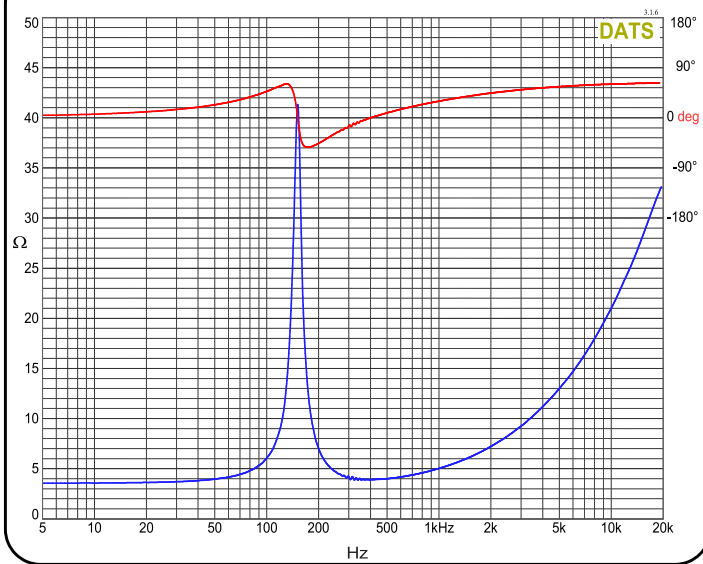

FEATURES

- High economic value
- Delivers crisp, clear audio, ensuring an immersive listening experience
- High-quality audio solutions without breaking the bank, ideal for budget-conscious projects
- Suitable for commercial installations, DIY projects, art exhibits, and more

FREQUENCY RESPONSE

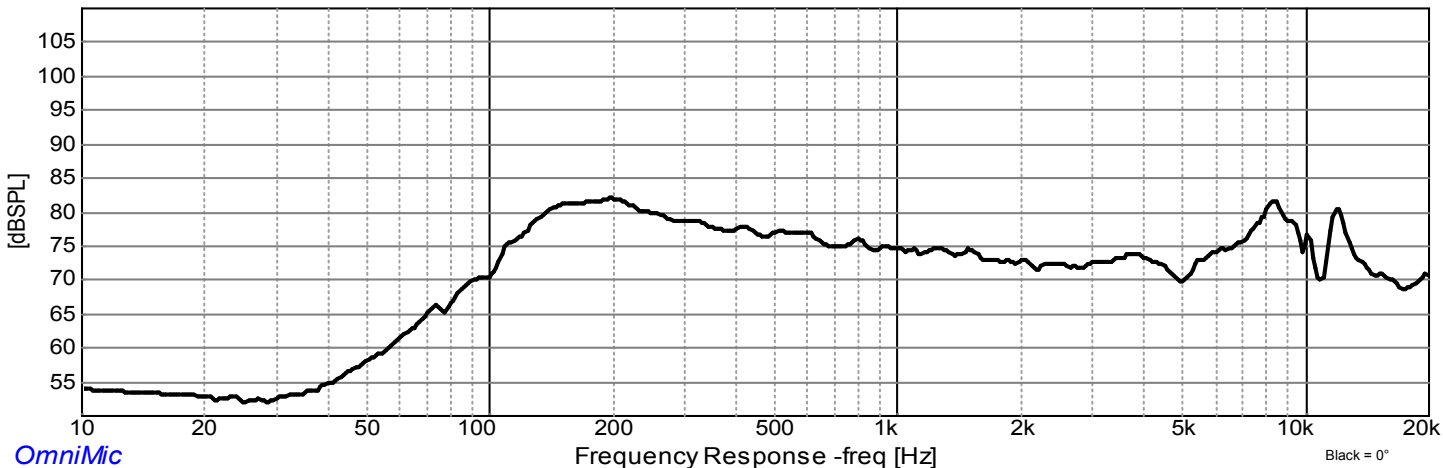

OmniMic

Frequency Response -freq [Hz]

Black = 0°

Note: 1/24th octave smoothing - near field response included in graph below 450 Hz.