

# **DCS165-4 Down-Firing Subwoofer Kit Assembly**

Thank you for purchasing the DCS165-4 Down-Firing Subwoofer kit. This kit was precision cut using CNC machinery for the best possible fit and finish. With a little time and patience, your finished product will provide years of enjoyment. Please use the following instructions for the best possible results.

## **Suggested tools and consumables:**

Drill	Rag or paper towels
5/64" drill bit	Solder
Wood clamps (you can never have too many of these)	Soldering iron
Sanding block and/or electric finishing sander	Wood glue
Speaker or hook-up wire (14-16 gauge)	Binding post/terminal cup
Pencil or Sharpie marker	Phillips screwdriver
#8 x 3/4" Pan head wood screws	Plate Amplifier

## **Package contents:**

First, empty the contents of the package and review parts to ensure everything has been included and is in good condition. If any parts are missing or damaged please contact our customer service department at 1-800-338-0531.

## **Components:**



**A**



**B**

**A) 1 x Dayton Audio DCS165-4 6-1/2" Classic Subwoofer 4 Ohm**

**B) 1 x Port Tube 2" ID Adjustable**

**Enclosure:**

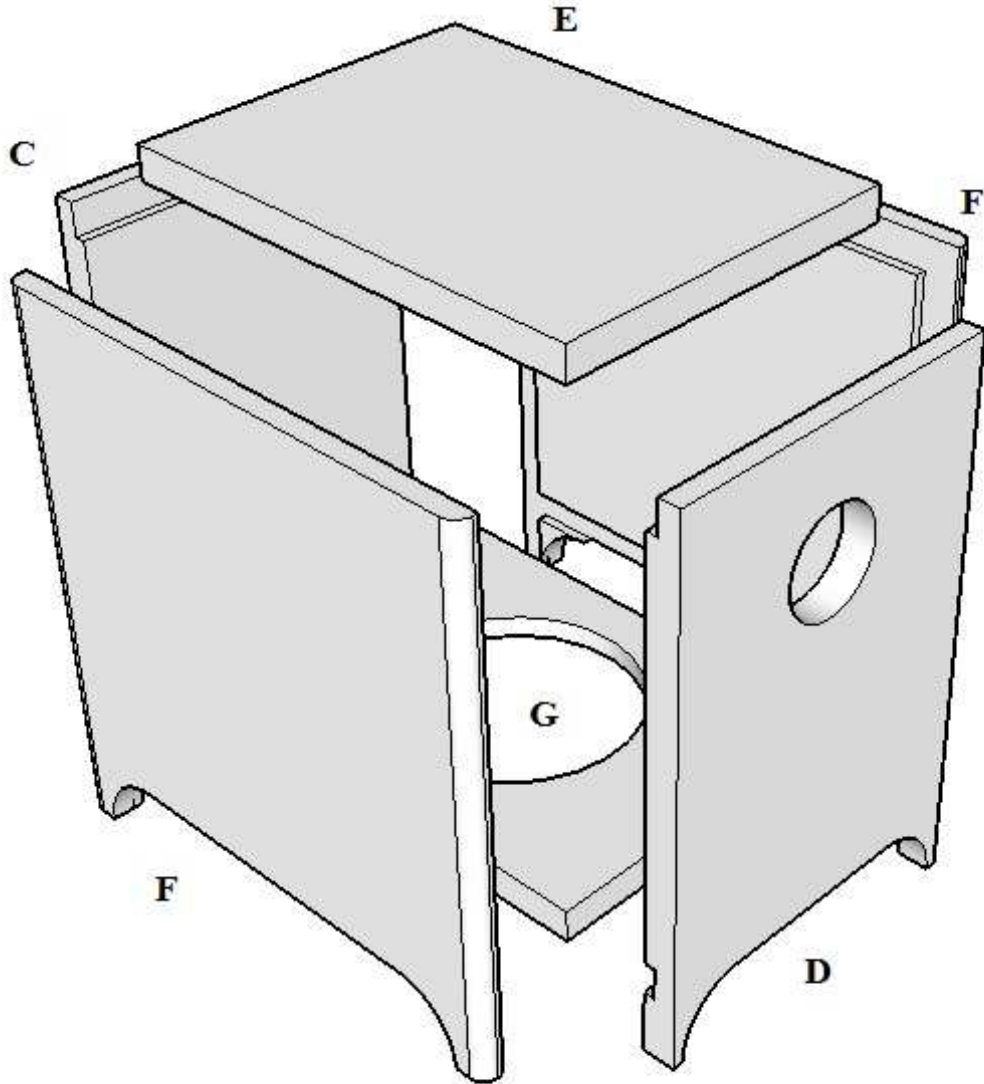

- C) Front
- D) Back
- E) Top
- F) 2 x Sides
- G) Bottom

### **Enclosure Assembly:**

- 1) First, take either the back or bottom panel and cut or drill holes required for the speaker termination of your choice (plate amplifier, binding posts, terminal cup, Speakon, etc...).
- 2) Next, set the enclosure parts out on a flat level surface and ensure that all pieces are free of dust and debris.
- 3) With one side panel lying flat, glue all mating surfaces of each panel in the order shown below. Due to the placement of dado cuts, this cabinet should require only a few clamps for assembly and gluing.

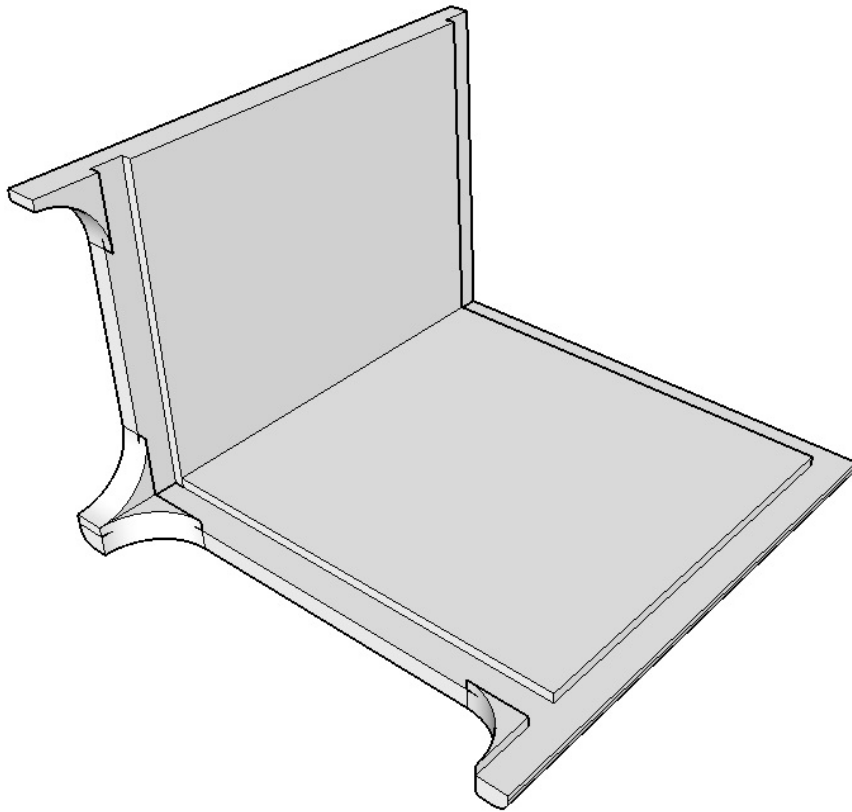

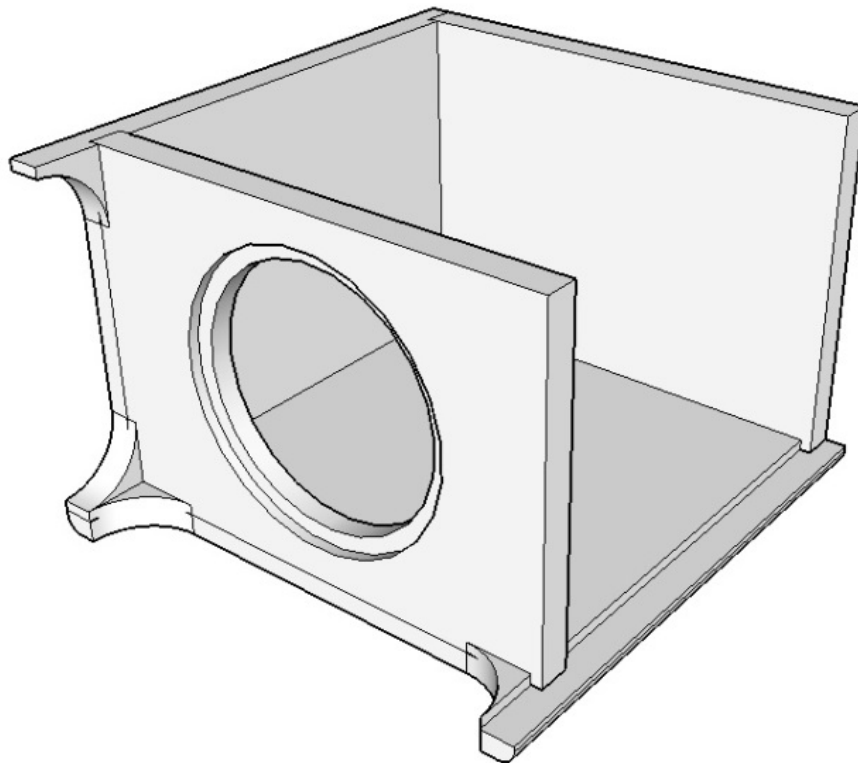
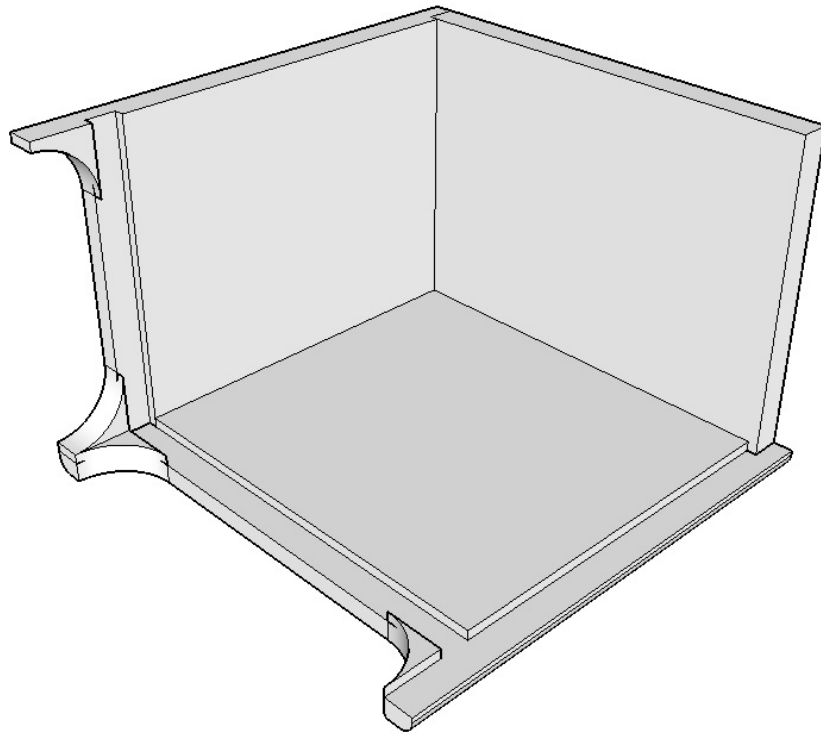

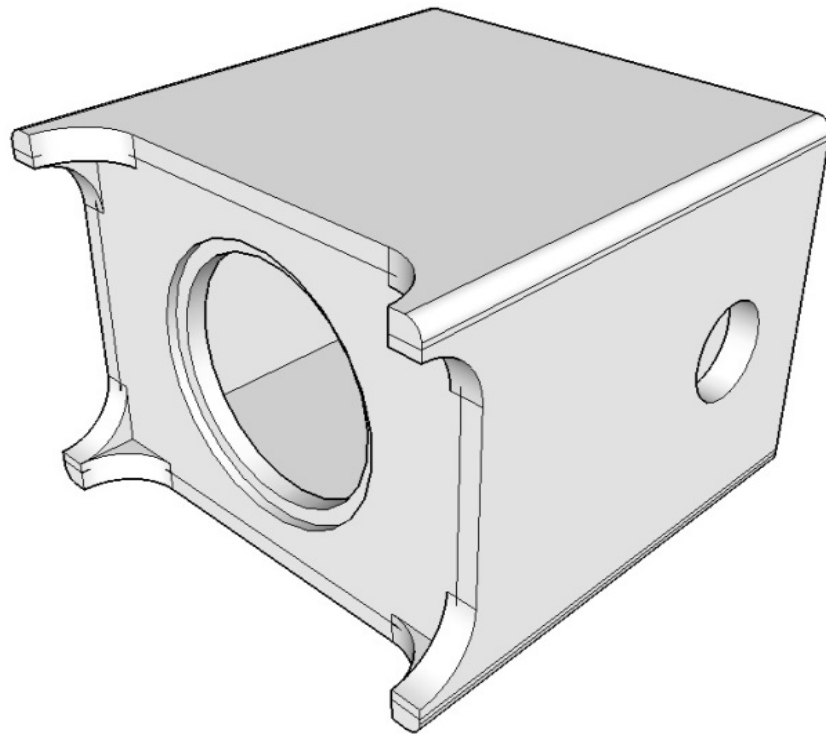
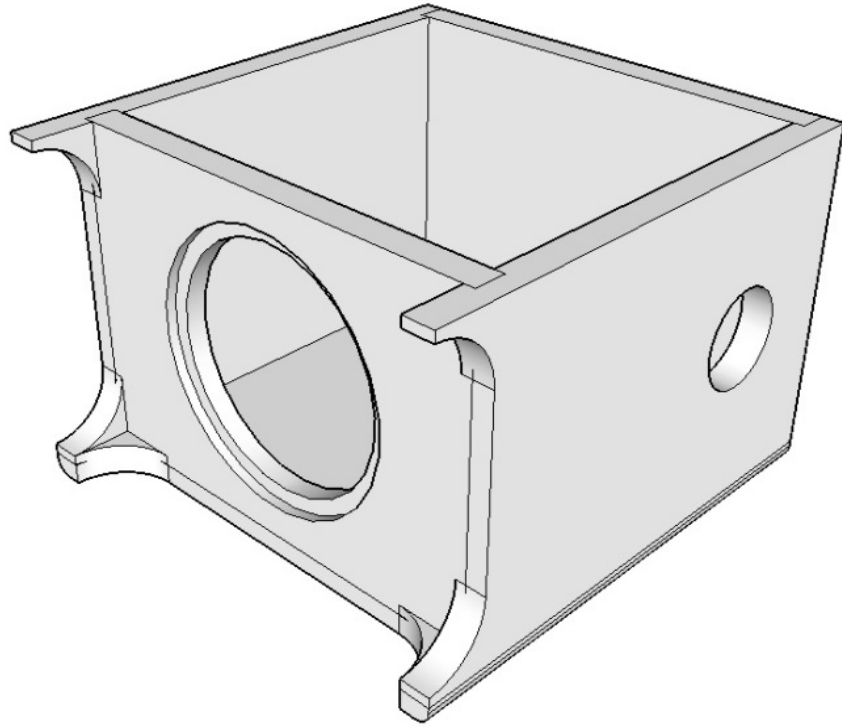

- 4) Make sure all mating surfaces have flush edges and stand the enclosure up on its legs. Apply four clamps from side to side along the edges, at least two clamps from front to back and at least two clamps from the top panel to the bottom.
- 5) Using a damp rag or paper towel, wipe away any glue squeeze-out on the outside of the enclosure (excess glue on the inside is fine). Allow to dry according to the glue manufacturer's recommendations and remove clamps.
- 6) Sand and finish enclosure to your liking. See our web page for examples.

### **Final Assembly:**

- 7) Solder 12-14" of speaker wire to the binding posts or terminals of your choice, observing proper polarity. Install terminals.
- 8) Place woofer in its recessed cutout and mark the screw holes with a sharpie or pencil. Remove woofer and pilot drill these marks using your 5/64" drill bit. Repeat this process for installing the port tube. Clean up the resulting sawdust.
- 9) Install your choice of sound damping material. We recommend ½ pound of Acousta-Stuf (part number 260-317) or lining the interior walls with our ½" Sonic Barrier peel and stick foam (part number 260-520).
- 10) Connect the wire from the terminals to the woofer, observing proper polarity.
- 11) Determine the length of port you would like to use. With no extension used, the tuning frequency will be around 52 Hz. With the full length of the extension used the tuning will drop to 41 Hz. We recommend a length of 8-10" for the best results. You can use electrical tape, super glue or hot glue to hold the port extension in place.

**\*Note – the port extension may have to be installed from inside the cabinet due to the tight tolerances of the port opening. We recommend installing the port before the woofer for this reason.**

- 12) Install the port and woofer using a hand screwdriver. We do not recommend using a power drill for this because it can easily slip and damage the woofer cone or surround.
- 13) You are now ready to enjoy your finished 6-1/2" Down-Firing Subwoofer kit!



**Additional parts used:**

- |          |  |
|----------|--|
| 300-4002 | Lepai LP210PA 2x30W + 60W 2.1 Channel Mini Plate Amplifier TPA3118 |
| 350-515  | VViViD XPO Dry Carbon Black Premium Film Vinyl Wrap 5 ft. x 3 ft.  |
| 081-422  | Parts Express #8 x 3/4" Deep Thread Pan Head Screws Black 100 Pcs. |
| 320-435  | Adhesive Rubber Feet Dome Shaped 12-Pack                           |
| 100-016  | Audtek Electronics SKRL-16-50 16 AWG OFC Speaker Wire 50 ft.       |