

Super tweeter for outstanding detail and clarity in high-frequencies without harshness. The ST400 BLK may be used individually in lower power systems or arrayed for increased coverage and SPL in higher power systems.

The base and diffuser are constructed of aluminum contributes to better heat dissipation of the coil moves, with finish machining of diamond (diamond tool) and varnished.

The bullet-shape horn design offers a longer throw 40° x 40° dispersion.

The phenolic annular diaphragm is long-lasting, cost-effective and more natural-sounding than metallic diaphragms.

The use of high-temperature materials and adhesives improves power handling and produces exceptionally high acoustic output.

Together with magnetic ring of aluminum ensuring a high-definition and efficiency across its fixed playback.

Connectors with quick couplings

A precisely engineered diaphragm structure and alignment mechanism for easy, reliable, cost effective repair in case of diaphragm failure.



SPECIFICATIONS

Nominal impedance 8 Ω
Minimum impedance @ 9,400 Hz 7.8 Ω

RMS POWER USING CROSSOVER	ACTIVE ³	PASSIVE ⁴
AES (HPF 1,5KHz - 12dB/oct) ²	20	W
AES (HPF 2,0KHz - 12dB/oct) ²	20	W

MUSIC PROGRAM POWER USING CROSSOVER
(HPF 5,000 Hz - 12dB/oct)¹ 200 W
(HPF 8,000 Hz - 12dB/oct)¹ 300 W

Sensitivity (2.83V@1m) averaged from 6 to 15 kHz 111 dB SPL
Frequency response @ -10 dB 4,000 to 20,000 Hz
Sound dispersion (H x V) 40 x 40 degrees
Diaphragm material Phenolic
Voice coil diameter 42 (1.6) mm (in)
Re 6.2 Ω
Flux density 1.70 T

¹ Power handling specifications refer to normal speech and/or music program material, reproduced by an amplifier producing no more than 5% distortion. Power is calculated as true RMS voltage squared divided by the nominal impedance of the loudspeaker. This voltage is measured at the input of the recommended passive crossover when placed between the power amplifier and loudspeaker.
Musical Program= 2 x W RMS

² AES: Recommended practice AES2-1984(r2003): Test with duration of 2h with pink noise (6dB of crest factor) filtered since the specified frequency to one decade above.

³ Active: The signal pass through a filter (DSP's, active crossovers) before being amplified. The referred power is measured at transducer terminals .

⁴ Passive: The signal pass through a passive filter (ex. electric circuits with capacitor or/and inductors) after being amplified. The referred power is measured at the filter terminals.

WARNING: Must be connected with an appropriate crossover.

ADDITIONAL INFORMATION

Magnet material Barium ferrite
Magnet weight 470 (16.5) g (oz)
Magnet diameter x depth 102 x 14 (4.02 x 0.55) mm (in)
Magnetic assembly weight 1,200 (2.64) g (lb)
Housing material Aluminum
Housing finish Machined, painted
Voice coil material CCAW
Voice coil former material Polyimide (Kapton®)
Voice coil winding length 2.2 (7.2) m (ft)
Voice coil winding depth 2.0 (0.08) mm (in)
Wire temperature coefficient of resistance (α25) 0.00356 1/°C
Volume displaced by tweeter 0.6 (0.022) l (ft³)
Net weight 1,690 (3.13) g (lb)
Gross weight 1,740 (3.72) g (lb)
Carton dimensions (W x D x H) 12.0 x 14.0 x 10.0 (4.7 x 5.5 x 3.9) cm (in)

MOUNTING INFORMATION

Number of bolt-holes 4
Bolt-hole dimensions 4 x 5.5 (0.16 x 0.21) mm (in)
Distance between bolt-holes (H x V) 86 x 91 (3.38 x 3.59) mm (in)
Baffle cutout diameter (front mount) 106 (4.17) mm (in)
Connectors Push terminals
Polarity Positive voltage applied to the positive terminal
(red) gives diaphragm motion toward the horn throat

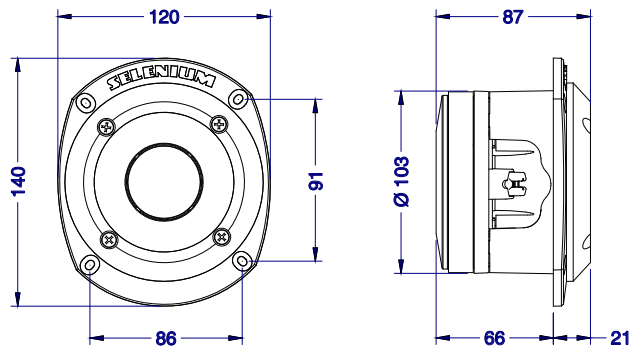
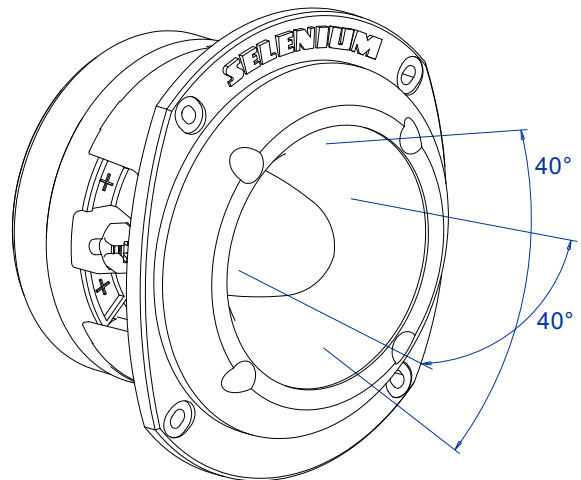

RESPONSE CURVE MEASURED IN ANECHOIC CHAMBER, 1 W / 1 m

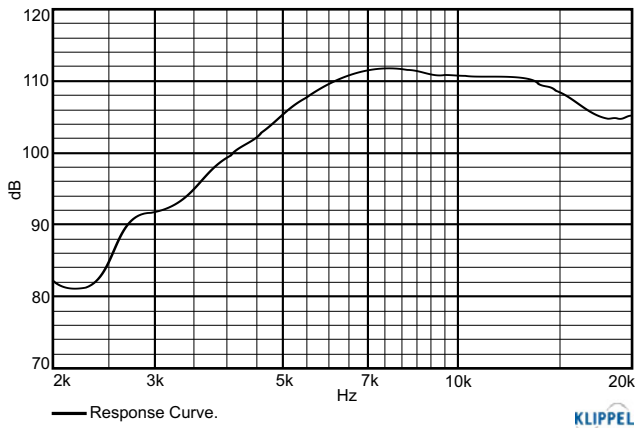

HARMONIC DISTORTION CURVES, 2.5 W / 1 m.

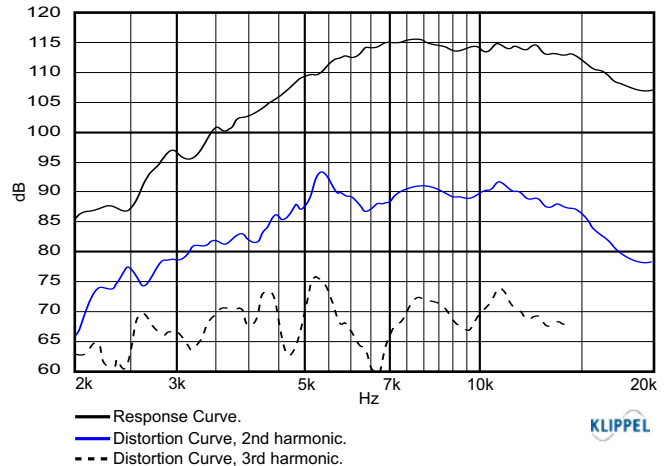

IMPEDANCE AND PHASE CURVES MEASURED IN FREE-AIR.

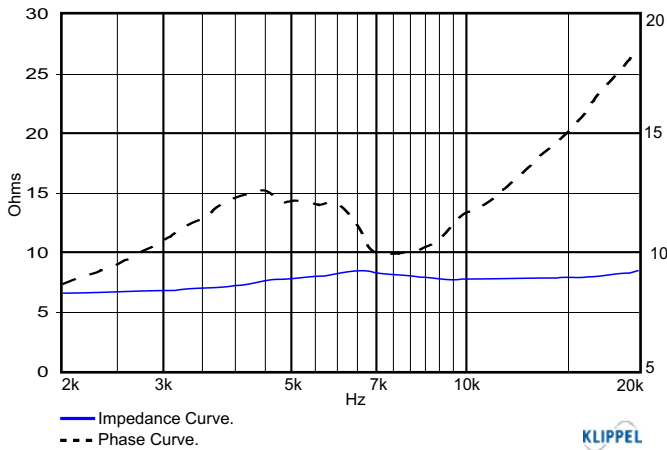

POLAR RESPONSE CURVES

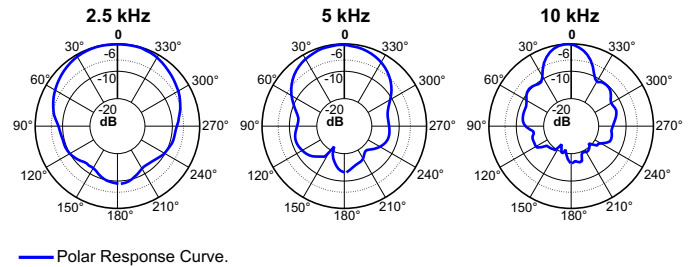

HARMONIC DISTORTION CURVES, 1 W / 1 m.

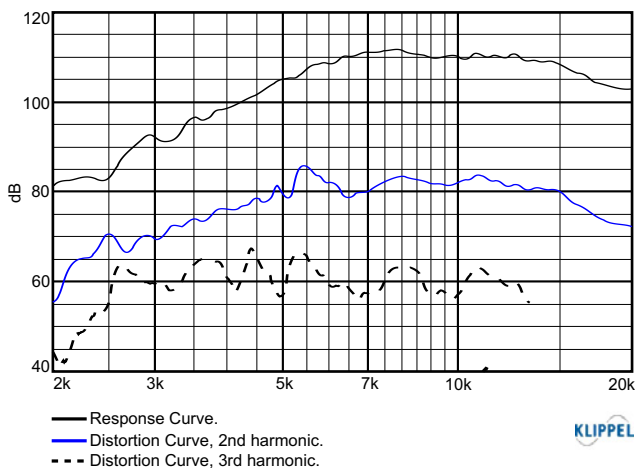

HOW TO CHOOSE THE RIGHT AMPLIFIER

The power amplifier must be able to supply twice the RMS driver power. This 3 dB headroom is necessary to handle the peaks that are common to musical programs. When the amplifier clips those peaks, high distortion arises and this may damage the transducer due to excessive heat. The use of compressors is a good practice to reduce music dynamics to safe levels.

FINDING VOICE COIL TEMPERATURE

It is very important to avoid maximum voice coil temperature. Since moving coil resistance (R_e) varies with temperature according to a well known law, we can calculate the temperature inside the voice coil by measuring the voice coil DC resistance:

$$T_B = T_A + \left(\frac{R_B}{R_A} - 1 \right) \left(T_A - 25 + \frac{1}{\alpha_{25}} \right)$$

T_A, T_B = voice coil temperatures in °C.

R_A, R_B = voice coil resistances at temperatures T_A and T_B , respectively.

α_{25} = voice coil wire temperature coefficient at 25 °C.

Kapton®: Du Pont trademark.