

Technical Data

Rated power	80 W
Maximum power	110 W
Nominal impedance Z	8 Ohm
Frequency response	fu-6000 Hz
(fu: Lower cut-off frequency depending on cabinet)	.
Mean sound pressure level	88 dB (1 W/1 m)
Excursion limit	+/-6 mm
Resonance frequency fs	34 Hz
Magnetic induction	1,0 T
Magnetic flux	310 μWb
Height of front pole-plate	4 mm
Voice coil diameter	25 mm
Height of winding	15 mm
Cutout diameter	225 mm
Net weight	1,25 kg
D.C. resistance Rdc	5,9 Ohm
Mechanical Q factor Qms	2,82
Electrical Q factor Qes	2,92
Total Q factor Qts	1,43
Equivalent volume Vas	113 l
Effective piston area Sd	346 cm²
Dynamically moved mass Mms	33 g
Force factor Bxl	3,8 T m
Inductance of the voice coil L	0,8 mH
Connections	5,2 x 0,8 mm (+) 2,8 x 0,8 mm (-)

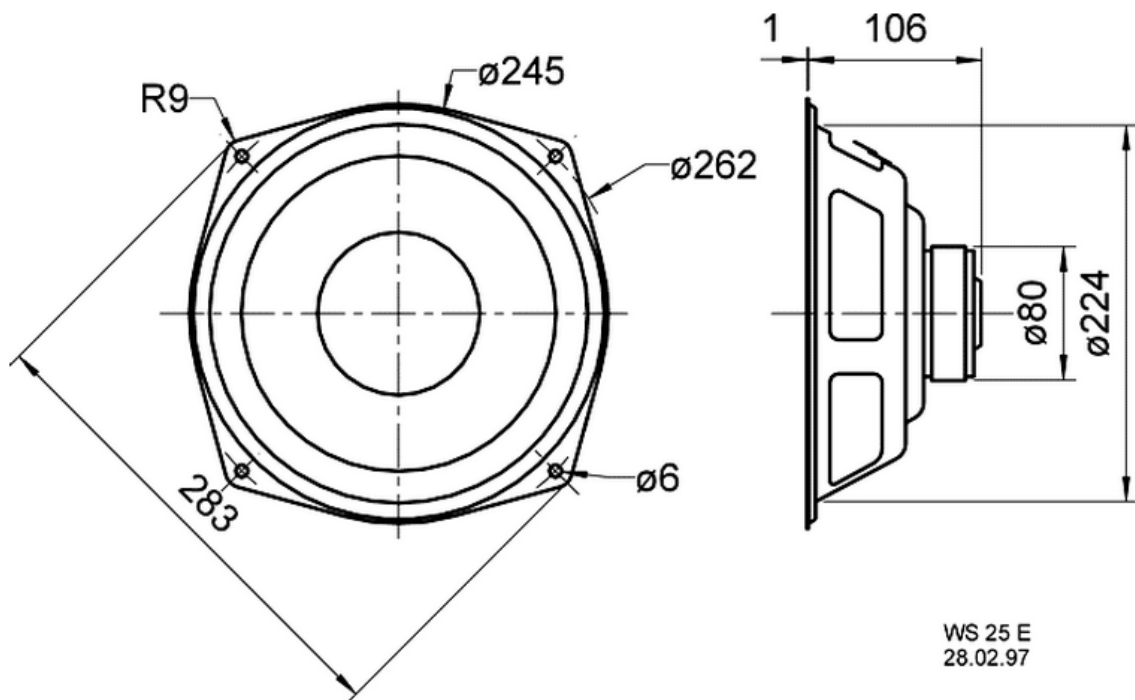

Visaton WS 25 E - 8 Ohm

Frequenzgang und Impedanz

