

F SERIES

W3-871SC

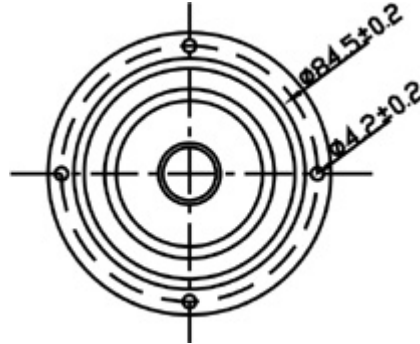
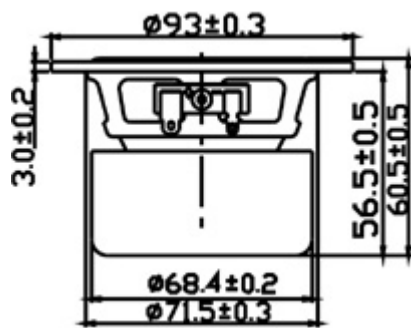

3" PAPER FULL RANGE

- FULL RANGE FREQUENCY RESPONSE
- ROUND STAMPING STEEL BASKET
- ALUM. PHASE PLUG
- PAPER CONE WITH SANTOPRENE SURROUND
- MAGNETICALLY SHIELDED
- ALUMINUM PHASE PLUG COILING

DIAPHRAGM MTL	Silver Paper
SURROUND MTL	Santoprene
NOMINAL IMPEDANCE	8 Ω
DCR IMPEDANCE	6.6 Ω
SENSITIVITY 1W/1m	87 dB
FREQUENCY RESPONSE	110-20K Hz
FREE AIR RESONANCE	110 Hz
VOICE COIL DIAMETER	18 mm
AIR GAP HEIGHT	6 mm
RATED POWER INPUT	12 W
MAXIMUM POWER INPUT	25 W
FORCE FACTOR, BL	3.53 TM
MAGNET WEIGHT (4oz)	117 g
MOVING MASS	2 g
FERRO FLUID ENHANCED	No
SUSPENSION COMPL.	1145MN ⁻¹
EFFEC.PISTON AREA	0.0032M ²
Levc	0.29mH
Zo	73.8ohm
X-max	0.5 mm
Vas	1.66 Litr.
Qts	0.59
Qms	6.57
Qes	0.65



TB SPEAKERS

VOICE: 886.2.26570282 FAX: 886.2.26580166
E-MAIL: info@tb-speaker.com

CLOSE