

JAB Series

2 x 30 Watt Class D Audio Amplifier Board w DSP - JAB3 (AA-JA32473)



Key Features:

- 3.60 x 2.70 Inches PCB Size
- Battery Board Supported*
- Power Management Circuit
- DSP Integrated
- Gain of Speaker Output Adjustable
- High-pass Filter of Speaker Output
- Overall Volume Adjustable
- PBTL Configurable
- Signal Level Sensor System*
- External 3.5mm AUX IN Port
- Power Switch Port*
- 3.5mm Headphone Output
- Compatible with JAB2*

Distributors:



All Audio Amplifier boards are complied with ROHS and they are pre-tested with our power supply solution to comply with FCC and CE. We could provide FCC, CE and RoHs certifications for customers' convenience. The test reports will be provided upon requests by e-mails only for customers who apply for bulky purchasement of MOV USD\$10,000 or MOQ 500pcs.

Ready for:



Contact Info

• Email:
info@wondom.com



Electrical Specifications

Specifications typical @ +25°C, Powered by 24V DC, unless otherwise noted. Specifications subject to change without notice.

Parameter	Conditions	Min.	Typ.	Max.	Units	
Number of Channels	-	-	2	-	-	
Minimum Load Impedance	-	3.2	4	-	Ω	
Efficiency	2 x 30W@80hm, 1kHz	-	84	-	%	
Nominal Power Requirement	@24V, 1kHz	-	130	-	W	
Operating Voltage	@1kHz, 80hm	12	24	26	V	
Idle Power	Signal detected	-	2	-	W	
	No Signal detected	-	60	-	mW	
Switching Frequency	SD Floating@24V	-	400	-	kHz	
Power Consumption	1/4 of max output power@80hm, 24V, 1kHz	-	20	-	W	
	1/8 of max output power@80hm, 24V, 1kHz	-	10	-	W	
Control	Standby (Low = inputs enabled)	High-level Input Voltage	6.0	-	-	V
		Low-level Input Voltage	-	-	0.4	V
	Mute (High = outputs enabled)	High-level Output Voltage	3.5	-	-	V
		Low-level Output Voltage	-	-	0.4	V
Standby Power	SD short to GND, only when low power module available	-	120	-	mW	
Under Voltage Protection	-	10.0	10.4	10.8	V	

Audio Performance

Specifications typical @ +25°C, powered by 24V DC, unless otherwise noted. Specifications subject to change without notice.

Parameter	Conditions	Min.	Typ.	Max.	Units	
Amp Gain	@80hm, 20Hz - 20kHz	-	26	-	dB	
DSP Gain	SE1 (Single Amp)	@80hm, 1kHz	-60	-	0	dB
	SE2 (Headphone)	@80hm, 1kHz	-60	-	6.5	dB
Input Sensitivity	2 x 30W@80hm, 1kHz, 26dB	-	770	-	mV	
Filter Gain	Butterworth, Q= 0.707	-	4	-	dB	
Cutoff Frequency	HFP	0.25	-	2	kHz	
	LFP	-	20	-	kHz	
SNR	2 x 30W@80hm, THD+N=1%, 26dB, A-weighting	-	88	-	dB	
THD+N	5W@80hm, 1kHz, 24dB	-	0.04	-	%	
	10W@80hm, 1kHz, 24dB	-	0.06	-	%	
Input Impedance	-	-	10	-	kΩ	
Supported Sampling Rates	-	-	48	-	kHz	
Output Noise Level	A-weighting, Input Connected to GND, 26dB	-	260	-	uV	
DC Offset	-	-	10	-	mV	
Max output Level	J3, 3.5mm Headphone Output Connector	-	7.8	-	dBu	
Crosstalk Separation	20Hz-20kHz, Gain=26dB	-	-60	-	dB	

***Notes:

1. The JAB3 can be powered up by battery board. Please kindly be noticed that the batteries could not be charged through JAB3 and Battery Protection and Balancing Board. Connect power adapter and Battery Protection and Balancing Board to JAB2 when you need to charge the batteries. This means you must have a JAB2 if you want to charge the batteries.
2. Audio Signal detection technology has been employed in JAB3 for low power consumption. When the JAB3 does not detect signal for around 1min, it will enter into standby mode automatically and restart playing when audio signal is found.
3. The board realize standby when connecting 'STBY' with 'GND'. Please be noticed that 'MUTE' can not be connected with 'GND' for mute mode. See details in 'Connection and Pin Definition'.
4. JAB3 can be connected with JAB2 through J5 port with a 6-pin PH cable. The cable is provided in the Functional Cables Package for JAB3.

All parameters were tested with Rohde & Schwarz UPV audio analyzer (AES17 filter enabled) and Audio Precision AUX0025 filter. For authorized distributors and OEM customers who need more detailed performance graphs and parameter settings, please send an inquiry e-mail to us. (Not available for retail customers)

Function of Potentiometers

Functions of potentiometers based on specific applications

Port	Function	JAB3S	JAB3M	JAB3S+ JAB2	JAB3M+ JAB2
POT1	CH1 Gain	Gain of Speaker Output	Gain of Speaker Output	Gain of Speaker Output of JAB3	Gain of Speaker Output of JAB3
POT2	CH1 HPF or BPF	High-pass Filter of Speaker Output	Band-pass Filter of Speaker Output	High-pass Filter of Speaker Output of JAB3	Band-pass Filter of Speaker Output of JAB3
POT3	CH2 HPF	High-pass Filter of 3.5mm Headphone Output	High-pass Filter of 3.5mm Headphone Output	High-pass Filter of Stereo of JAB2	High-pass Filter of Stereo of JAB2
POT4	CH1 & CH2 Volume	Volume of Speaker & 3.5mm Headphone Output	Volume of Speaker & 3.5mm Headphone Output	Overall Volume of JAB3 & JAB2	Overall Volume of JAB3 & JAB2

Note:

- The speaker output (J10) of the board with potentiometers is defined as CH1; 3.5mm headphone output (J3) or other integrated circuit output of the board with potentiometers is defined as CH2.
- JAB3S refers to JAB3 in stereo mode, namely 2 x 50 Watt Class D Audio Amplifier Board w DSP - JAB3 (AA-JA32172) and 2 x 30 Watt Class D Audio Amplifier Board w DSP - JAB3 (AA-JA32473); JAB3M refers to JAB3 in mono mode, namely 1 x 100 Watt Class D Audio Amplifier Board w DSP - JAB3 (AA-JA31181) and 1 x 60 Watt Class D Audio Amplifier Board w DSP - JAB3 (AA-JA31211).
- HPF refers to High-pass Filter; BPF refers to Band-pass Filter.
When CH1 is stereo output, the function of POT2 is HPF; when CH1 is mono output, the function of POT2 is BPF.
- Four applications are exemplified in this datasheet. For the functions of potentiometers when used in other applications, please contact us at store@sure-electronics.com.

Function	Range of Frequency
High-pass Filter	250Hz- 2kHz
Band-pass Filter (Adjusting in Frequency band)	60Hz-120Hz (High-pass)
	200Hz-400Hz (Low-pass)

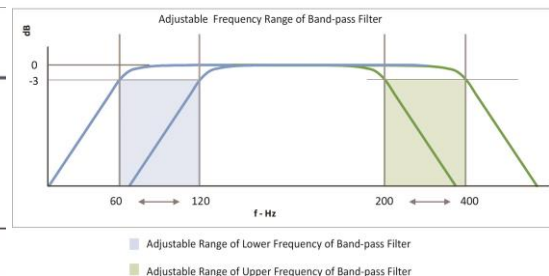
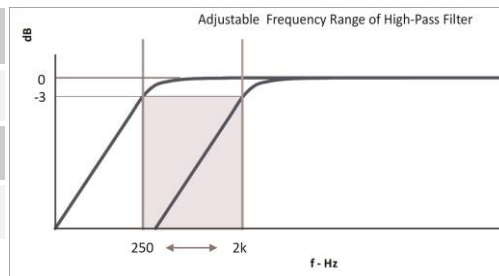

Mechanical Dimensions

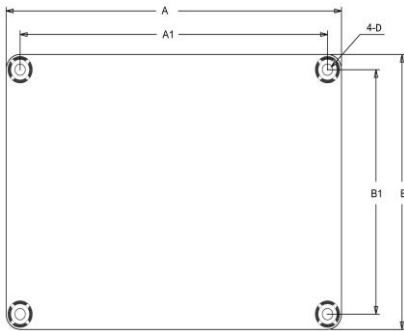

Dimensions	A (inch/mm)	A1 (inch/mm)	B (inch/mm)	B1 (inch/mm)	D (inch/mm)
	3.60/91.44	3.30/83.8	2.70/68.6	2.40/61.0	0.14/3.6

Connections

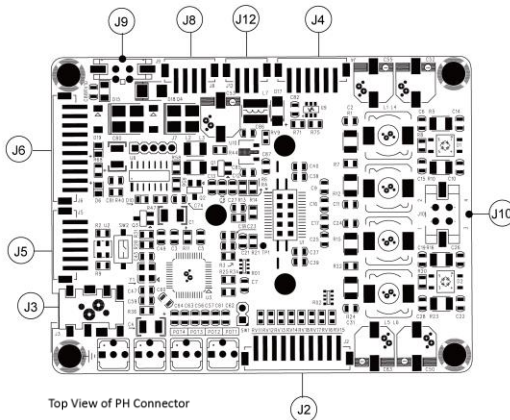

Top View of PH Connector

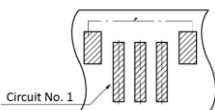

Circuit No. 1

Notes:

- All dimensions are typical in inches/mm
- Tolerance x.xx = ±0.02(±0.50)

DSP Extension Port:

·J2, PH- 10Pin- 2mm

Pin	Definition	Pin	Definition
1	GND	6	MP00
2	DATA	7	MP01
3	LRCLK	8	MP05
4	BCLK	9	MP04
5	MP07	10	+3.3V

Programming Connector:

·J4, PH- 6Pin- 2mm

Pin	Definition	Pin	Definition
1	SDA	4	GND
2	SCL	5	VIN
3	WP	6	RST

Power Supply Connector:

·J9, Molex- 2Pin- 3mm

Pin	Definition
1	VCC
2	GND

Switch Control Connector*:

·J12, PH- 3Pin- 2mm

Pin	Definition
1	STBY
2	GND
3	MUTE

Audio Output Connector:

- J10, Speaker Output Connector
- J3, 3.5mm Headphone Output Connector

Audio Extension and Compatible Port:

·J5, PH- 6Pin- 2mm

Pin	Definition	Pin	Definition
1	LIN	4	GND
2	LOUT	5	ROUT
3	GND	6	RIN

Extension Connector:

·J6, PH- 10Pin- 2mm

Pin	Definition	Pin	Definition
1	VCC	6	LIN
2	VCC	7	GND
3	GND	8	RIN
4	LED1	9	KEY2
5	KEY1	10	LED2

Battery Board Connection Connector:

·J8, PH- 4Pin- 2mm

Pin	Definition	Pin	Definition
1	VBAT	3	GND
2		4	

*Notes:

- Short circuit 'STBY' and 'GND' to enter into 'Standby' mode.
- Don't short circuit 'MUTE' and 'GND' at any time. This position is used to synchronize with 'MUTE' pin on JAB1/ 2 to eliminate the popping noise.
- When JAB3 is used separately, the 'MUTE' position will malfunction; when JAB3 is used together with JAB1 or JAB2, J12 must be connected with the control port on JAB1/ 2 for controlling the whole system. Short circuit 'STBY' or 'MUTE' and 'GND' on JAB1/ 2 for system control.



Sure Electronics
Make Your Audio Application Simple!

www.sure-electronics.com

www.wondom.com

Mail: store@sure-electronics.com

Skype: surewebstore