

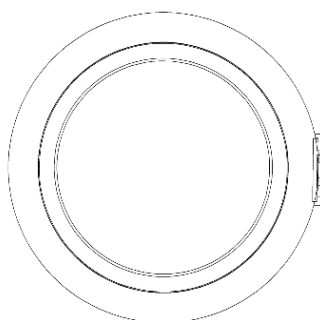

MIDRANGE

D7608/920000

The Discovery series offer traditional design, superior sound, a solid construction, and a wide range of variants. Combining these elements - plus a wealth of technical features and finesses - it gives our customers the possibility of acquiring a tailor-made Scan-Speak solution with very good performance at a reasonable low price point!

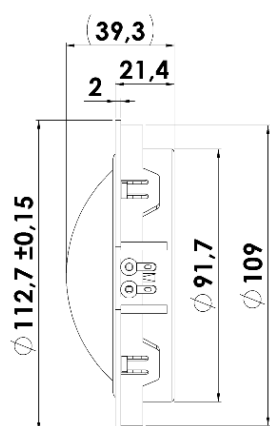

KEY FEATURES:

- Fast action due to low moving mass
- High SPL Output 92dB
- Internal Ferrite Magnet
- Wide Dispersion
- Vented / open rear side
- Internal grill to prevent dome from being pushed in

T-S Parameters

| | |
|-------------------------------|--------------------|
| Resonance frequency [fs] | 300 Hz |
| Mechanical Q factor [Qms] | 7.75 |
| Electrical Q factor [Qes] | 2.22 |
| Total Q factor [Qts] | 1.73 |
| Force factor [Bl] | 4.7 Tm |
| Mechanical resistance [Rms] | 0.80 kg/s |
| Moving mass [Mms] | 3.3 g |
| Suspension compliance [Cms] | 0.09 mm/N |
| Effective diaph. diameter [D] | 84 mm |
| Effective piston area [Sd] | 55 cm ² |
| Equivalent volume [Vas] | 0.36 l |
| Sensitivity (2.83V/1m) | 92 dB |
| Ratio Bl/√Re | 1.97 N/√W |
| Ratio fs/Qts | 174 Hz |

Notes:

IEC specs. refer to IEC 60268-5 third edition.
All Scan-Speak products are RoHS compliant.
Data are subject to change without notice.
Datasheet updated: February 22, 2011.

Electrical Data

| | |
|----------------------------|---------|
| Nominal impedance [Zn] | 8 Ω |
| Minimum impedance [Zmin] | 6.2 Ω |
| Maximum impedance [Zo] | 25.6 Ω |
| DC resistance [Re] | 5.7 Ω |
| Voice coil inductance [Le] | 0.13 mH |

Power Handling

| | |
|---------------------------------|------|
| 100h RMS noise test (IEC 17.1)* | 80 W |
| Long-term max power (IEC 17.3)* | - W |

*Filter: 2. order HP Butterworth, 500 Hz

Voice Coil and Magnet Data

| | |
|---------------------|----------|
| Voice coil diameter | 76 mm |
| Voice coil height | 2.9 mm |
| Voice coil layers | 2 |
| Height of gap | 2 mm |
| Linear excursion | ± 0.4 mm |
| Max mech. excursion | ± 1.5 mm |
| Unit weight | 0.6 kg |



MIDRANGE

D7608/920000

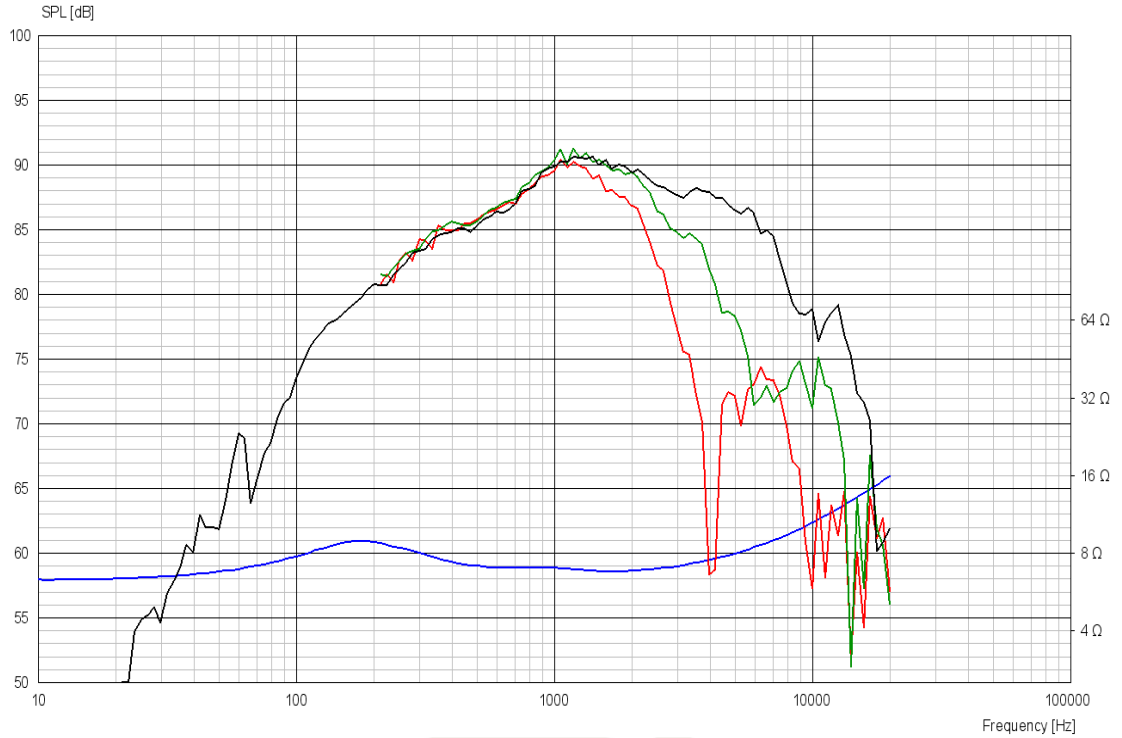

Advanced Parameters (Preliminary)

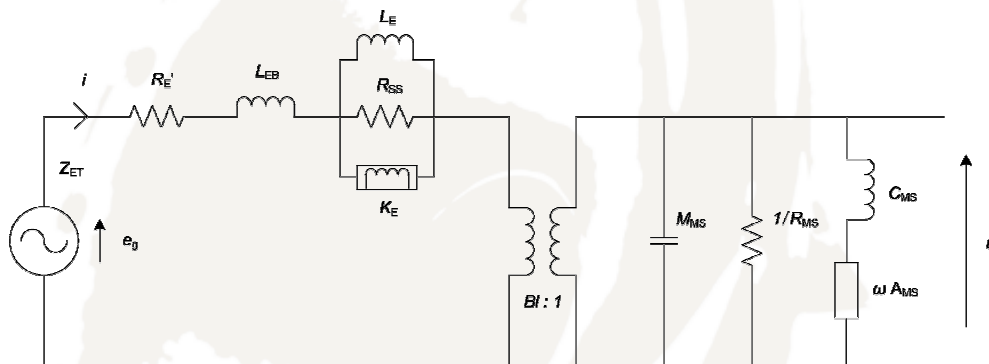

Electrical data:

| | |
|-------------------------------------|------|
| Resistance [Re'] | - Ω |
| Free inductance [L _{eb}] | - mH |
| Bound inductance [Le] | - mH |
| Semi-inductance [Ke] | - SH |
| Shunt resistance [R _{ss}] | - Ω |

Mechanical Data

| | |
|--|--------|
| Force Factor [Bl] | - Tm |
| Moving mass [M _{ms}] | - g |
| Compliance [C _{ms}] | - mm/N |
| Mechanical resistance [R _{ms}] | - kg/s |
| Admittance [A _{ms}] | - mm/N |