

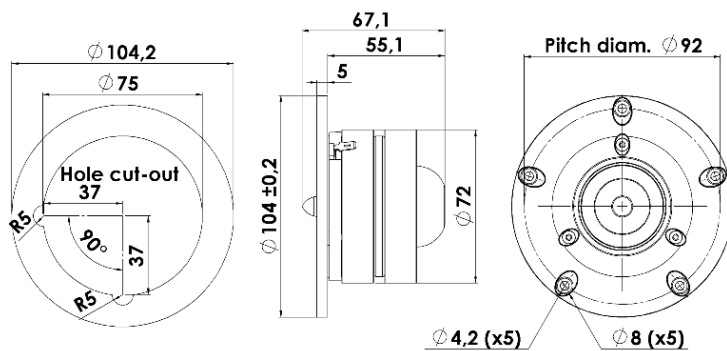

TWEETER

R2604/833000

The Discovery series offer traditional design, superior sound, a solid construction, and a wide range of variants. Combining these elements - plus a wealth of technical features and finesses - it gives our customers the possibility of acquiring a tailor-made Scan-Speak solution with very good performance at a reasonable low price point!



KEY FEATURES:

- Extended Frequency To Above 40KHz
- Low Distortion
- Dual Ring Radiator diaphragm (Patent)
- Very Low Resonance Frequency - 450Hz
- High sensitivity - 92dB
- Wave-guide center plug (Patent)

T-S Parameters

Resonance frequency [fs]	440 Hz
Mechanical Q factor [Qms]	2.18
Electrical Q factor [Qes]	0.46
Total Q factor [Qts]	0.38
Force factor [Bl]	2.3 Tm
Mechanical resistance [Rms]	0.38 kg/s
Moving mass [Mms]	0.3 g
Suspension compliance [Cms]	0.44 mm/N
Effective diaph. diameter [D]	26 mm
Effective piston area [Sd]	5.4 cm ²
Equivalent volume [Vas]	0.02 l
Sensitivity (2.83V/1m)	92 dB
Ratio Bl/ \sqrt{Re}	1.35 N/ \sqrt{W}
Ratio fs/Qts	1169 Hz

Notes:

IEC specs. refer to IEC 60268-5 third edition.
All Scan-Speak products are RoHS compliant.
Data are subject to change without notice.
Datasheet updated: February 22, 2011.

Electrical Data

Nominal impedance [Zn]	4 Ω
Minimum impedance [Zmin]	3.6 Ω
Maximum impedance [Zo]	16.8 Ω
DC resistance [Re]	2.9 Ω
Voice coil inductance [Le]	0.02 mH

Power Handling

100h RMS noise test (IEC 17.1)*	100 W
Long-term max power (IEC 17.3)*	- W

*Filter: 2. order HP Butterworth, 2.5 kHz

Voice Coil and Magnet Data

Voice coil diameter	26 mm
Voice coil height	2.2 mm
Voice coil layers	2
Height of gap	2.5 mm
Linear excursion	± 0.2 mm
Max mech. excursion	± 1.6 mm
Unit weight	0.8 kg



TWEETER

R2604/833000

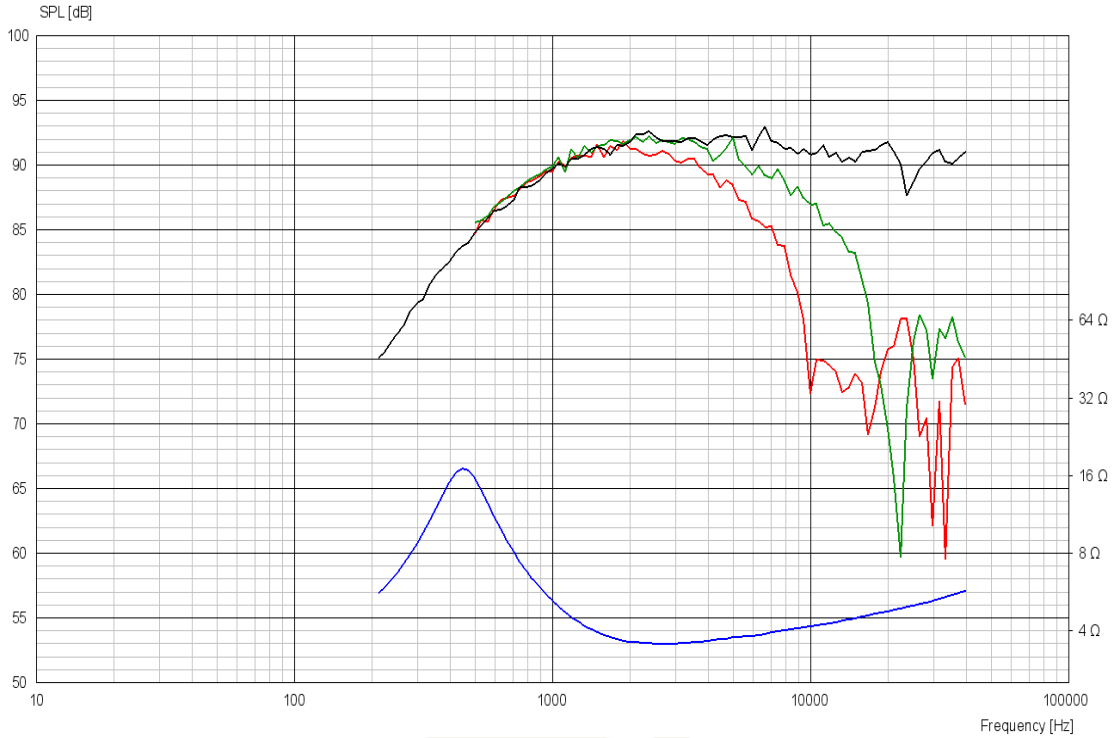

Advanced Parameters (Preliminary)

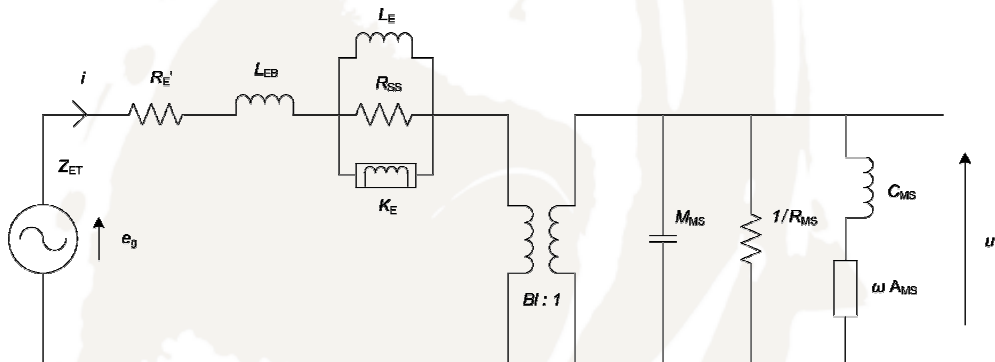

Electrical data:

Resistance [Re']	- Ω
Free inductance [L _b]	- mH
Bound inductance [Le]	- mH
Semi-inductance [Ke]	- SH
Shunt resistance [R _{ss}]	- Ω

Mechanical Data

Force Factor [Bl]	- Tm
Moving mass [M _{ms}]	- g
Compliance [C _{ms}]	- mm/N
Mechanical resistance [R _{ms}]	- kg/s
Admittance [A _{ms}]	- mm/N