

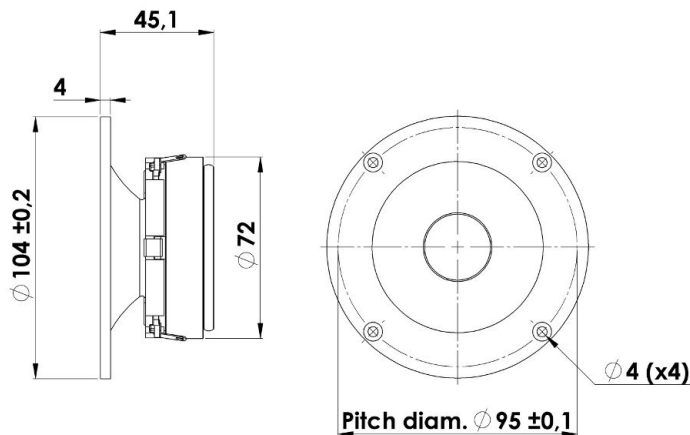

TWEETER

H2606/920000

The Discovery series offer traditional design, superior sound, a solid construction, and a wide range of variants. Combining these elements - plus a wealth of technical features and finesses - it gives our customers the possibility of acquiring a tailor-made Scan-Speak solution with very good performance at a reasonable low price point!



KEY FEATURES:

- Horn Loaded High Sensitivity Tweeter
- Low Damping Ferrofluid Cooling
- Coated Textile Diaphragm
- High Stability
- High Performance Tweeter
- Dampened Cavity in Pole Piece

T-S Parameters

Resonance frequency [fs]	1030 Hz
Mechanical Q factor [Qms]	2.1
Electrical Q factor [Qes]	1.2
Total Q factor [Qts]	0.7
Force factor [Bl]	3.3 Tm
Mechanical resistance [Rms]	1.3 kg/s
Moving mass [Mms]	0.4 g
Compliance [Cms]	- mm/N
Effective diaph. diameter [D]	26 mm
Effective piston area [Sd]	5.7 cm ²
Equivalent volume [Vas]	- l
Sensitivity (2.83V/1m)	95.2 dB
Ratio Bl/√Re	1.5 N/√W
Ratio fs/Qts	- Hz

Notes:

IEC specs. refer to IEC 60268-5 third edition.
All Scan-Speak products are RoHS compliant.
Data are subject to change without notice.
Datasheet updated: January 21, 2016.

Electrical Data

Nominal impedance [Zn]	6 Ω
Minimum impedance [Zmin]	5.0 Ω
Maximum impedance [Zo]	14.2 Ω
DC resistance [Re]	4.7 Ω
Voice coil inductance [Le]	0.05 mH

Power Handling

100h RMS noise test (IEC 17.1)*	100 W
Long-term max power (IEC 17.3)*	200 W

*Filter: 2. order HP Butterworth, 2.5 kHz

Voice Coil & Magnet Data

Voice coil diameter	25 mm
Voice coil height	1.6 mm
Voice coil layers	2
Height of gap	2 mm
Linear excursion	± 0.2 mm
Max mech. excursion	± 1.6 mm
Unit weight	0.6 kg



TWEETER

H2606/920000



Advanced Parameters (Preliminary)

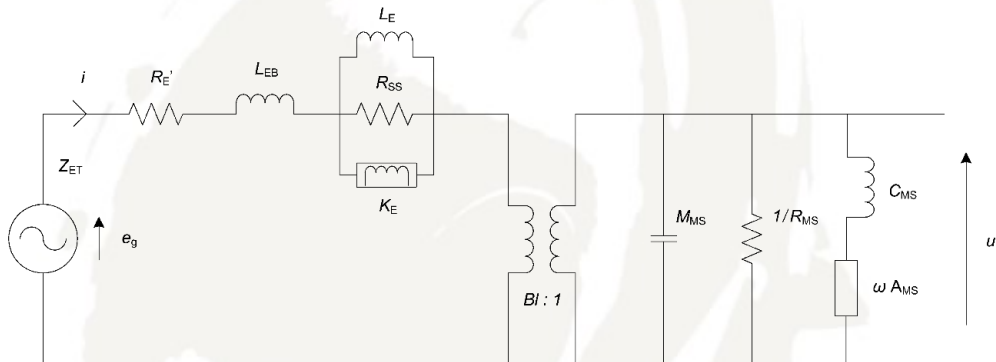

Electrical data

Resistance [Re']	- Ω
Free inductance [Leb]	- mH
Bound inductance [Le]	- mH
Semi-inductance [Ke]	- SH
Shunt resistance [Rss]	- Ω

Mechanical Data

Force Factor [BI]	- Tm
Moving mass [Mms]	- g
Compliance [Cms]	- mm/N
Mechanical resistance [Rms]	- kg/s
Admittance [Ams]	- mm/N