

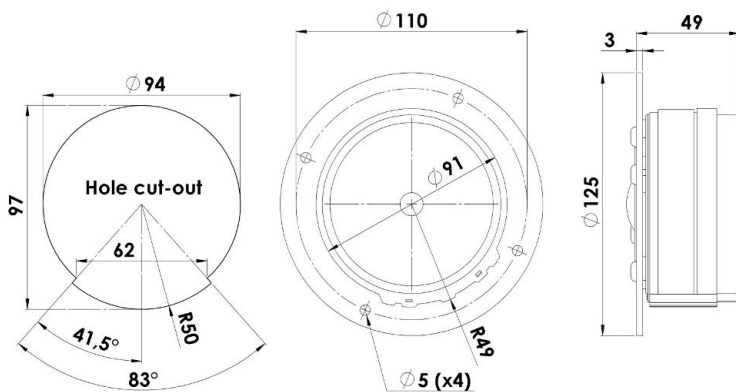

## TWEETER

## D3806/820000

D3806/820000 was one the very first Scan-Speak products, now been on the market more than 4 decades and continuing being successful as one of the best upper midranges on the market.



### KEY FEATURES:

- 1½" Textile Dome Diaphragm
- Patented Symmetrical Drive (SD-2) motor
- Black Painted Alu Face Plate
- Optimized for Upper Midrange
- Low Resonant Rear Chamber

#### T-S Parameters

Resonance frequency [fs]	450 Hz
Mechanical Q factor [Qms]	0.93
Electrical Q factor [Qes]	1.00
Total Q factor [Qts]	0.48
Force factor [Bl]	3.6 Tm
Mechanical resistance [Rms]	2.44 kg/s
Moving mass [Mms]	0.8 g
Compliance [Cms]	0.16 mm/N
Effective diaph. diameter [D]	42 mm
Effective piston area [Sd]	14 cm <sup>2</sup>
Equivalent volume [Vas]	0.04 l
Sensitivity (2.83V/1m)	89 dB
Ratio Bl/√Re	1.51 N/√W
Ratio fs/Qts	938 Hz

#### Notes:

IEC specs. refer to IEC 60268-5 third edition.  
All Scan-Speak products are RoHS compliant.  
Data are subject to change without notice.  
Datasheet updated: January 17, 2019.

#### Electrical Data

Nominal impedance [Zn]	6 Ω
Minimum impedance [Zmin]	6.3 Ω
Maximum impedance [Zo]	11.0 Ω
DC resistance [Re]	5.7 Ω
Voice coil inductance [Le]	0.04 mH

#### Power Handling

100h RMS noise test (IEC 17.1)*	100 W
Long-term max power (IEC 17.3)*	- W

\*Filter: 2. order HP Butterworth, 1 kHz

#### Voice Coil & Magnet Data

Voice coil diameter	38 mm
Voice coil height	3.2 mm
Voice coil layers	2
Height of gap	2.5 mm
Linear excursion	± 0.4 mm
Max mech. excursion	± 1 mm
Unit weight	1.1 kg



# TWEETER

# D3806/820000

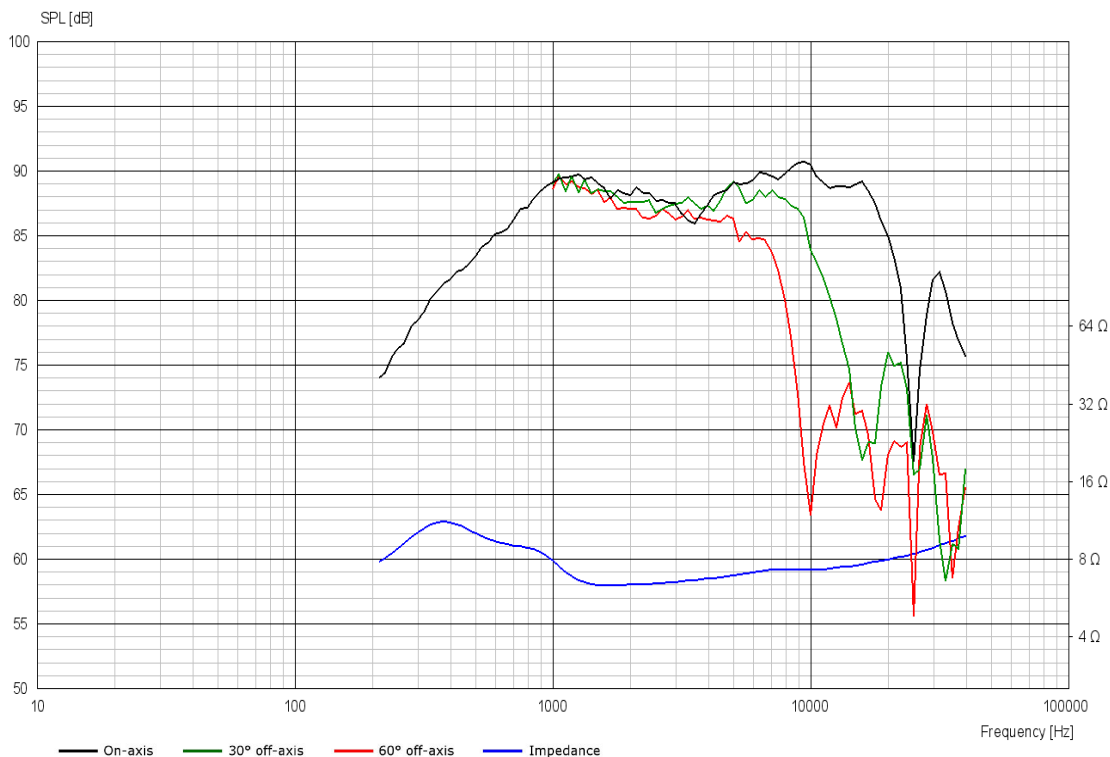

## Advanced Parameters (Preliminary)

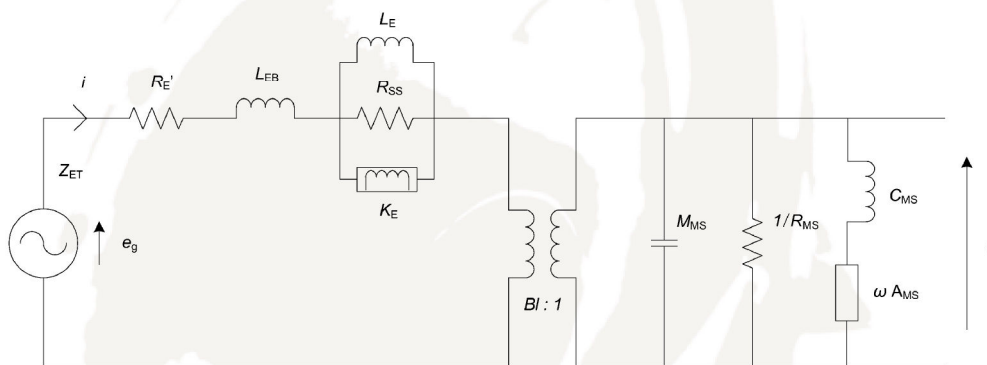

### Electrical data

Resistance [ $R_{E'}$ ]	- $\Omega$
Free inductance [ $L_{EB}$ ]	- mH
Bound inductance [ $L_E$ ]	- mH
Semi-inductance [ $K_E$ ]	- SH
Shunt resistance [ $R_{SS}$ ]	- $\Omega$

### Mechanical Data

Force Factor [ $BI$ ]	- Tm
Moving mass [ $M_{MS}$ ]	- g
Compliance [ $C_{MS}$ ]	- mm/N
Mechanical resistance [ $R_{MS}$ ]	- kg/s
Admittance [ $A_{MS}$ ]	- mm/N