

CHR-70A (Gen. 3)

Extended Full-Range emitter
Brushed Metal colour cone model



CHR-70A Gen. 3 Extended Full Range audio driver.

The CHR-70A (Gen. 3) is now up-dated 4 times since the first model was launched 4 years ago. Its usable frequency range is class leading. Depending on enclosure design, its capable of operation from 40Hz to 25-kHz.

2 developments further improve the design. An excursion limiter (arrestor) has now been fitted inside the motor sub-assembly, significantly reducing the risk of over-driving damage. The CHR is now capable of being driven at higher loads making it suitable for more audio applications. Colour coded custom locking connectors are now included in this design. Both these features are illustrated in the following page.

The driver has medium efficiency of 85.5dB at 8 Ohms making it easy to use on nearly all small to medium power amplifiers.

Many technical improvements has been done.

- 1 - Improved stiffer frame.
- 2 - New cap design with new improved fitting method.
- 3 - New Japanese deigned coil.
- 4 - New spider for improved bass.
- 5 - 2 colour choice (champagne gold and brush look metal cones)
- 6 - Built-in overload protection (arrestor in motor sub-assembly)
- 7 - Dedicated custom colour coded connectors

The new CHR-70 Gen. 3 is an excellent high-end and multi-purpose driver. Its also suitable for many computer, Home Theatre, TV, and commercial A/V applications.

CHR-70 Gen.3	Data
REVC	7.2 Ohm
Fo	65.40 Hz
Sd	5.02 K mm ²
Vas	5.17 Ltrs
Cms	1.44 uM/N
Mmd	3.90 g
Mms	4.10 g
BL	4.20 T*M
Qms	2.66
Qes	0.69
Qts	0.55
Levc	32.44 uH
No	0.20%
Spl	85.4 dB
Pwr	20w Nom.
X max	4.3-mm 1 way
Coil Dia	20-mm
Main tolerance	+/- 2.5 hz on mean Fo

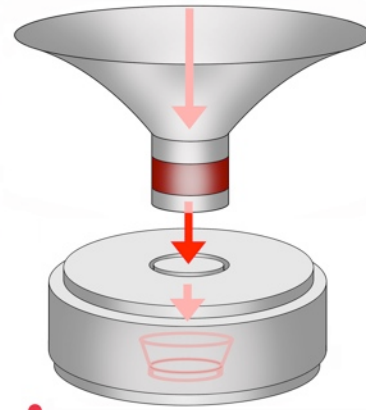

©markaudio - November 2012
All rights reserved.

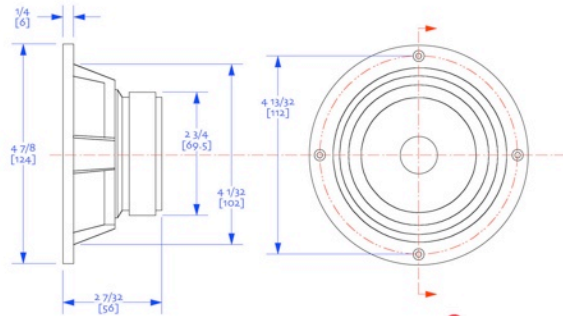

Note that these come with a 2mm gasket, which doesn't compress very much, so it needs to be accounted for when cutting the rebates.

CHR-70.3
CHR-70.2
CHBW-70
driver dimensions
drawn by did | 23june-2011

Small to medium sized speakers are usually lower power designs. The power rating is given in the technical data for each audio driver. For a reliable long service life, please operate your new speakers with care. The "A" driver comes with built-in overload protection, significantly reducing the risk of damage from excessive loads.

For the first 100 hours, operate them at very low volumes. After this period, gradually increase the volume to a normal listening level. If you see the cone of the speakers making large movements, immediately turn the volume down. This will protect the speaker and your human hearing from damage. Factory mechanical defects for a period of 2 year. Excessive hard use (over-driving) and other damage caused during customer use is excluded from our warranty.

