

## Transformer Softstart with extra features



### Highlights

- 115V/230V operation
- Low power switch control
- Low weight: 175 gr
- Compact: 82 x 69 x 28\* mm

### Features

- Transformer inrush current limiter
- Push button control
- Temperature monitoring
- Single/dual LED indication

### Applications

- Toroidal transformers
- Mono amplifiers
- Multichannel amplifiers

### Description

Transformer inrush current is limited by means of a triac switching heavy-duty resistors in series with AC mains prior to relay switching. With an optional (bicolour) LED the status "On" or "Standby" can be indicated. In "Standby" the power-consumption will be less than 1.2W. The Softstart can operate with either a push button or a switch (jumper selectable). If additional thermal protection is required, a PTC-option is selectable. The Softstart can switch multiple transformers up to a total maximum of 1500VA. Maximum continuous current must not exceed 6A.

## Contents

HIGHLIGHTS.....	1
FEATURES.....	1
APPLICATIONS.....	1
DESCRIPTION.....	1
CONTENTS.....	2
<b>1 SAFETY PRECAUTIONS .....</b>	<b>3</b>
<b>2 APPLICATION NOTE .....</b>	<b>4</b>
<b>3 ELECTRICAL SPECIFICATIONS.....</b>	<b>4</b>
3.1 POWER SPECIFICATIONS .....	4
<b>4 IO SPECIFICATIONS .....</b>	<b>4</b>
4.1 PTC .....	4
4.2 LED .....	4
<b>5 CONNECTOR PINOUTS .....</b>	<b>5</b>
5.1 PUSH BUTTON CONNECT.....	5
5.2 SWITCH.....	5
5.3 PTC CONNECT .....	6
5.4 LED OUTPUT.....	6
5.5 FASTONS .....	6
5.6 INPUT VOLTAGE SELECT .....	6
<b>6 DIMENSIONS AND DRILL PATTERN.....</b>	<b>7</b>
6.1 TOP VIEW .....	7
<b>7 CONNECTION EXAMPLES .....</b>	<b>8</b>
7.1 115VAC MAINS OPERATION .....	8
7.2 230VAC MAINS OPERATION .....	8
7.3 EXAMPLE CONNECTION CONFIGURATIONS .....	8
<b>8 REVISIONS .....</b>	<b>9</b>
<b>9 DISCLAIMER.....</b>	<b>9</b>

## 1 Safety precautions



**This module operates at mains voltage and carries hazardous voltages at accessible parts. These parts may never be exposed to inadvertent touch. Observe extreme care during installation and never touch any part of the unit while it is connected to the mains. Disconnect the unit from the mains and allow all capacitors to discharge for 10 minutes before handling it.**



**Attention: Observe precautions for handling electrostatic sensitive devices. This module uses semiconductors that can be damaged by electrostatic discharge (ESD).**

**Damage due to inappropriate handling is not covered by warranty.**

**This product has no user-serviceable parts.**

This is a Safety Class 2 device. When mounting the module in an enclosure, a minimum safety distance of 6mm from the module to all possible conducting parts must be ensured to keep compliance with Safety Class 2. All parts enclosed by the red line carry hazardous voltages. This includes parts on the top and the bottom of the board.

If the enclosure is limited in height and shorter spacers are used to mount the module, an insulating sheet with a minimum thickness of 0.4mm must be installed below the model to keep compliance with safety class 2.

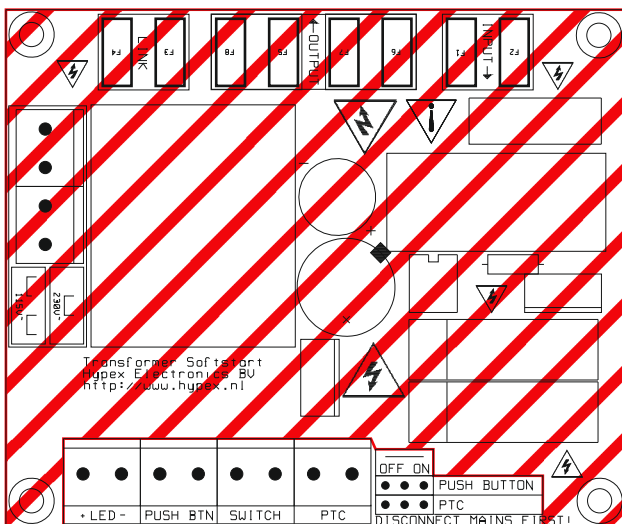

This symbol indicates the presence of hazardous voltages at accessible conductive terminals on the board.

**Warning:** To reduce the risk of fire or electric shock, do not expose this apparatus to rain or moisture.

1. Read these instructions.
2. Keep these instructions.
3. Heed all warnings.
4. Follow all instructions.
5. Do not use this apparatus near water.
6. Protect the power cord from being walked on or pinched, particularly at plugs, convenience receptacles, and the point where they exit from the application.
7. Only use attachments/accessories specified or approved by the manufacturer.
8. Unplug this apparatus during lightning storms or when unused for long periods of time.
9. Refer all servicing to qualified service personnel. Servicing is required when the apparatus has been damaged in any way, liquid has been spilled or objects have fallen into the apparatus, the apparatus has been exposed to rain or moisture, does not operate normally or has been dropped.
10. Don't run any cables across the top or the bottom of the module. Apply fixtures to cables to ensure that this is not compromised.
11. Observe a minimum clearance of 6mm with all possible conducting parts (housing etc.).
12. Natural convection should not be impeded by covering the module (apart from the end applications housing).
13. This product is to be used with Hypex modules only.
14. Before using this product, ensure all cables are correctly connected and the power cables are not damaged. If you detect any damage, do not use the product.
15. Changes or modifications not expressly approved by Hypex Electronics will void compliance and therefore the user's authority to operate the equipment.
16. Service or modifications by any person or persons other than by Hypex Electronics authorized personnel voids the warranty.

## 2 Application note

This module is designed as a toroidal transformer inrush current limiter. Although our DIY community has successfully used this module in combination with an SMPS, this has not been tested or approved by Hypex Electronics. As a service, in this datasheet, a connection diagram is given for the use of this module in combination with one SMPS400. Additional support on the use of this module in combination with SMPS cannot be given. Please note that this module is not recommended for new designs, since toroidal transformer based power supplies are no longer in our portfolio.

## 3 Electrical Specifications

### 3.1 Power Specifications

Parameter	Conditions	Symbol	Min	Typ	Max	Unit	Note
High Line Input Voltage	-	V <sub>B</sub>	180	230	264	Vac	1)
Low Line Input Voltage	With Low Line jumper placed	V <sub>B,FP</sub>	90	115	132	Vac	1)
Line Input Frequency	-	f	47		63	Hz	1)
Fuse rating	No fuse installed			none		A	

**Note 1:** Operation beyond these limits may result in irreversible damage.

## 4 IO Specifications

### 4.1 PTC

Optionally a PTC or thermistor can be mounted in/on the amplifier heat sink. When the temperature rises above the Nominal Response Temperature (NRT) the relay will fall off and shut the transformer down until the heatsink has cooled down. A 60°C NRT will be sufficient. Set the PTC-jumper to activate the protection.

NRT C	ID Color
60	white - grey
70	white - brown
80	white-white
90	green-green
100	red - red
110	brown - brown
120	grey - grey
130	blue - blue

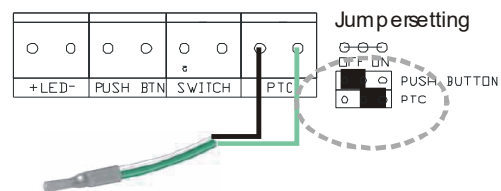

The Softstart will not operate unless the jumper is in the right position. Both jumpers are default in 'Off' position. Under normal conditions, PTC monitoring is not necessary.

### 4.2 LED

Two LED's (connected anti-parallel) indicate the state of the Softstart, enabled or standby. A bi-colour LED can also be connected between these outputs.

Parameter	Conditions	Symbol	Min	Typ	Max	Unit	Note
Voltage	Open clamps			3,7		Vdc	1)
Series resistor	Both polarities to ground	R <sub>led</sub>		3k3		Ω	

**Note 1:** Open clamp voltage is limited by Zener diodes. The internal supply voltage is actually approximately 15Vdc, therefore the current through your LED is  $(15Vdc - V_{fled}) / 3300 = I_{led}$ . Where  $V_{fled}$  is the forward voltage of your LED. This information is provided for more advanced DIY'ers. In most cases, just connecting two standard LED's is sufficient.

## 5 Connector Pinouts

This chapter describes the functional connectors of the power supply module. A connector not stated in this chapter is only used for production or quality control and must remain unconnected in the end user application. The arrow point towards pin1 of the connector.

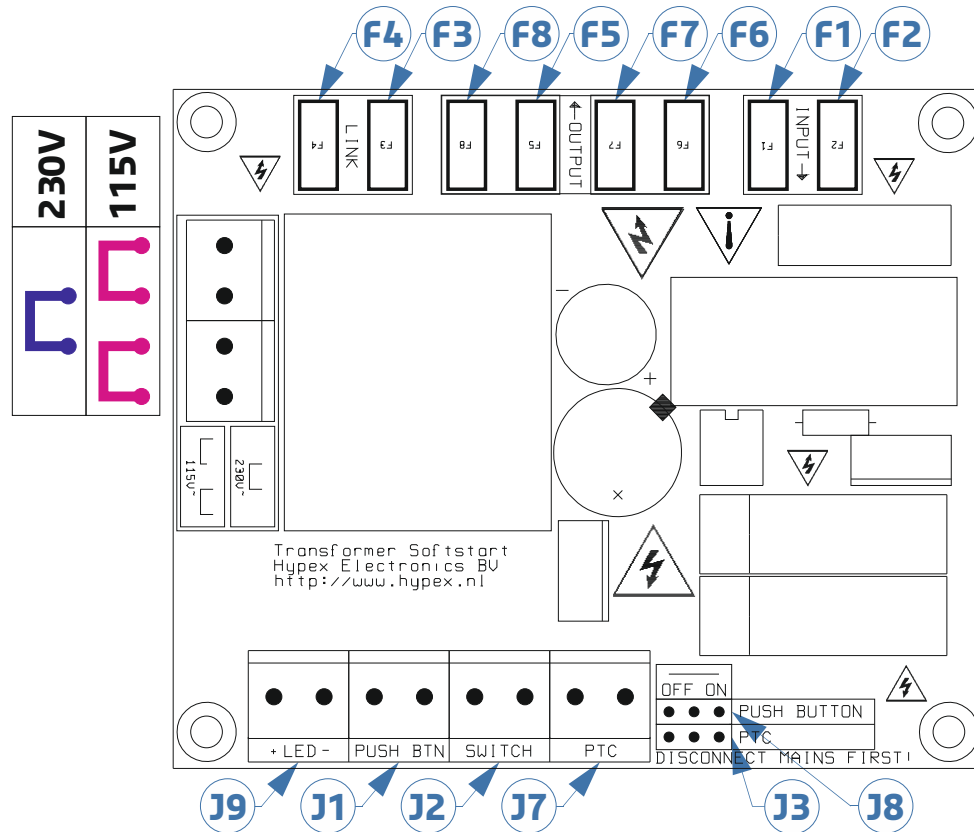

### 5.1 Push button connect

A push button can be connected to terminal J1. If a push button is connected, jumper J8 must be set to the 'on' position. Default position is 'off'.

**Maximum wire thickness:** 2.5 mm<sup>2</sup>

**Recommended/maximum tightening torque:** 0.5/0.6 Nm

### 5.2 Switch

A switch can be connected to terminal J2.

**Maximum wire thickness:** 2.5 mm<sup>2</sup>

**Recommended/maximum tightening torque:** 0.5/0.6 Nm

### 5.3 PTC Connect

Optionally a PTC can be connected to terminal J7. If a PTC is connected, jumper J3 must be set to the on position. If no PTC is connected, jumper J3 must be set to the 'off' position. Default position is 'off'. For more information see section 4.1 PTC.

**Maximum wire thickness:** 2.5 mm<sup>2</sup>

**Recommended/maximum tightening torque:** 0.5/0.6 Nm

### 5.4 LED output

Pin	Direction	Function	Remarks
J9.1	Output	Positive	See section 4.2 LED
J9.2	Output	Negative	See section 4.2 LED

**Maximum wire thickness:** 2.5 mm<sup>2</sup>

**Recommended/maximum tightening torque:** 0.5/0.6 Nm

### 5.5 Fastons

TAB	Direction	Function	Remarks
F1	Input	Mains input	
F2	Input	Mains input	
F6 F7	Output	Direct mains output from F1	F5 and F6 are conductively linked
F5 F8	Output	Switched mains output from F2	F5 and F8 are conductively linked
F3 F4	Link	Transformer link for 230V input use.	F3 and F4 are conductively linked

**Connector type equivalent:** 6,3x0,8 mm FASTON<sup>®</sup> tab

### 5.6 Input voltage select

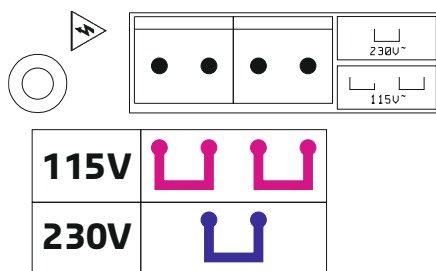

## 6 Dimensions and Drill pattern

### 6.1 Top view

If printed correctly (scale 100%, A4), the scale of the image below should be 1:1. You may use it as a model to drill holes in your casing. Please verify before drilling!

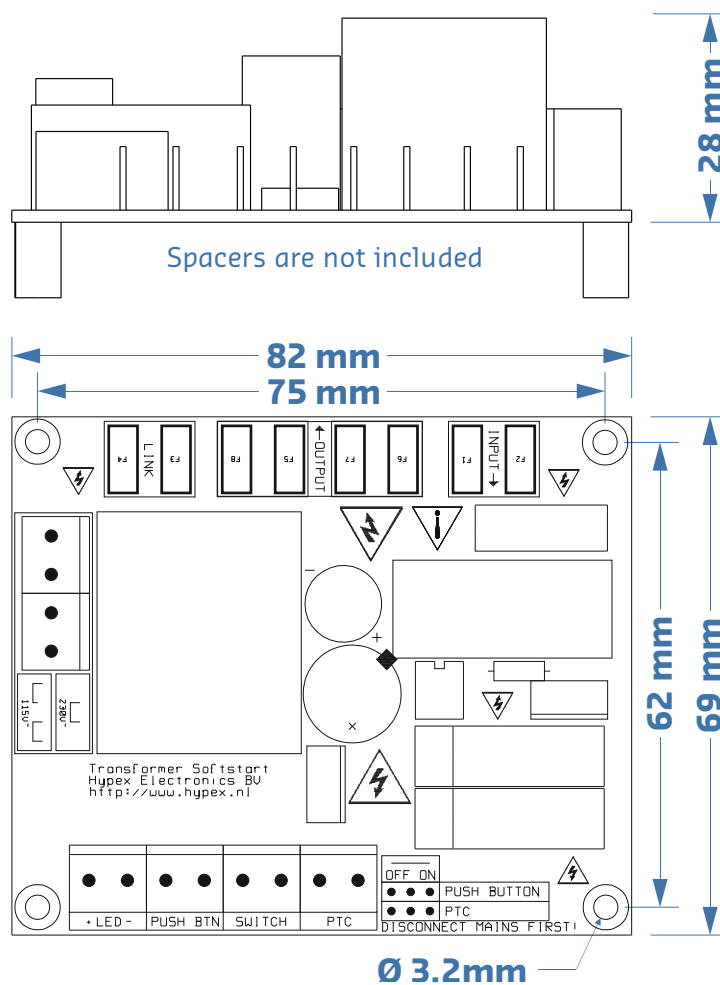

## 7 Connection examples

### 7.1 115Vac mains operation

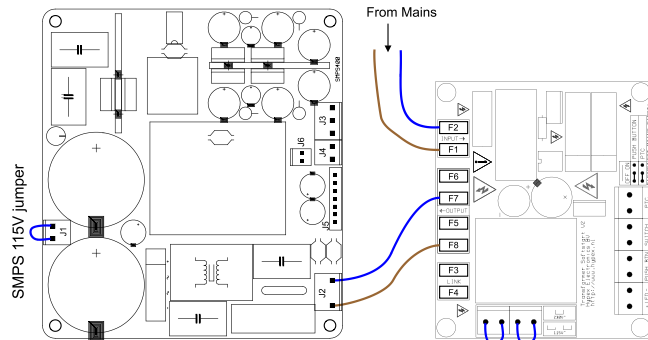
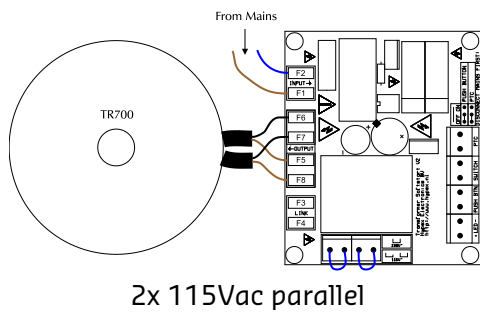

### 7.2 230Vac mains operation

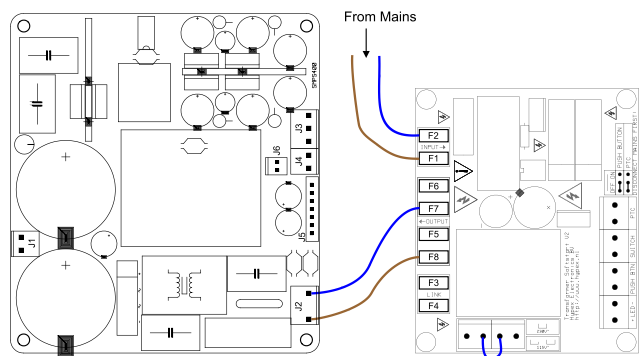
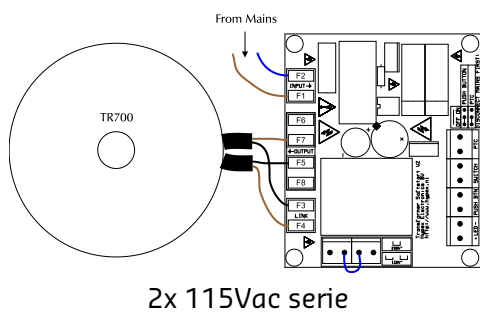

### 7.3 Example connection configurations

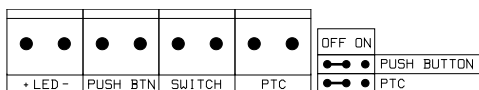

Default jumper settings. No extra's needed. Softstart module will automatically switch on after the mains power is applied.

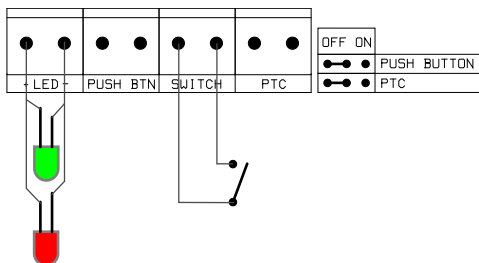

Two LED's (connected anti-parallel) indicate the state of the Softstart depending on the position of the switch.

Switch closed: Softstart is in standby. LED1 is lit.  
Switch opened: Softstart is switched on. LED2 is lit.

This switch can be a low voltage, low current type.

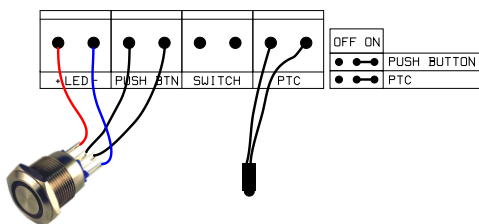

In this example a push button with LED integration and a PTC is connected.

To enable the PTC function, set jumper 'PTC' to the 'on' position.

To enable the push button function, set jumper 'push button' to the on position.



## 8 Revisions

Document revision	Module revision	Change log	Date
01	01xx	Release version	-
02	02xx	Updated and corrected	July '16

## 9 Disclaimer

All products, product specifications and data are subject to change without notice to improve reliability, function or design or otherwise.

Hypex Electronics BV, its affiliates, agents, and employees, and all persons acting on its or their behalf (collectively, "Hypex Electronics"), disclaim any and all liability for any errors, inaccuracies or incompleteness contained in any datasheet or in any other disclosure relating to any product.

This subassembly is designed for use in music reproduction equipment only. No representations are made as to fitness for other uses. Except where noted otherwise any specifications given pertain to this subassembly only. Responsibility for verifying the performance, safety, reliability and compliance with legal standards of end products using this subassembly falls to the manufacturer of said end product.

**LIFE SUPPORT POLICY:** Use of Hypex products in life support equipment or equipment whose failure can reasonably be expected to result in injury or death is not permitted except by explicit written consent from Hypex Electronics BV.