

26 mm Dome Tweeter

D2908/714000

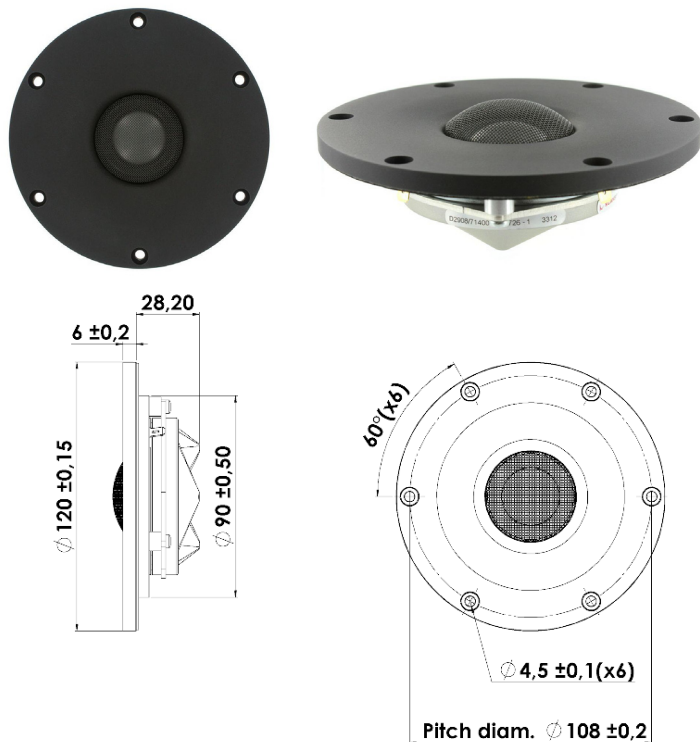

Key Features:

- Beryllium Diaphragm (99% Pure Be)
- Rear Mount Magnet System
- Patented Symmetrical Drive (SD-2) motor
- Titanium Voice Coil Former
- Black Anodized Ø120mm Machined Alu Faceplate
- Non Resonant Aluminium Rear Chamber

Recommendations (please see Tech Note):

- Operating frequency range: 2500-40000 Hz
- Cabinet volume - closed box: N.a.
- Cabinet volume - vented box: N.a.

T-S Parameters:

Resonance frequency [fs]	534 Hz
Mechanical Q factor [Qms]	7.3
Electrical Q factor [Qes]	0.50
Total Q factor [Qts]	0.47
Force factor [Bl]	3.6 Tm
Mechanical resistance [Rms]	0.15 kg/s
Moving mass [Mms]	0.33 g
Compliance [Cms]	0.26 mm/N
Effective diaph. diameter [D]	30 mm
Effective piston area [Sd]	7 cm ²
Equivalent volume [Vas]	0.02 l
Sensitivity (2,83V/1m)	92 dB

Mechanical Data:

Voice coil diameter	26 mm
Voice coil height	2.1 mm
Voice coil layers	2
Gap height	2.5 mm
Linear excursion	± 0.2 mm
Max mech. excursion	± 1.6 mm
Unit weight	0.5 kg
Cabinet Displacement Volume	- l

Electrical Data:

Nominal impedance [Zn]	8 Ω
Minimum impedance [Zmin]	6.5 Ω
Maximum impedance [Zo]	90 Ω
DC resistance [Re]	5.7 Ω
Voice coil inductance [Le]	0.02 mH

Power Handling:

100h RMS noise test (IEC 18.4)	160 W
Long-term max power (IEC 18.2)	200 W
X-over: 2. order HP Butterworth, 2.5 kHz	

