

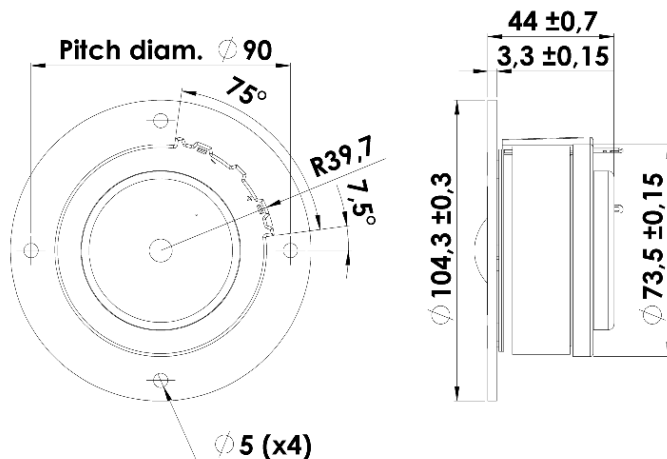

## TWEETER

## D2905/970000

The Classic tweeters are among the many highly praised designs in Classic series. They have enjoyed success over 3 decades. And still among the best tweeters available. The D2905/9000 tweeter kick-started a new era with a line of very high quality 1" tweeters, today known as -9300, -9500, -9700 and -9800. Despite their many years on the market still used in many top High-End speakers around the world.



### KEY FEATURES:

- 1" Textile Dome Diaphragm
- Patented Symmetrical Drive (SD-2) motor
- Frequency Extension to above 30KHz
- Low Resonance Rear Chamber
- Black Painted Alu Face Plate

#### T-S Parameters

Resonance frequency [fs]	500 Hz
Mechanical Q factor [Qms]	3.45
Electrical Q factor [Qes]	0.54
Total Q factor [Qts]	0.47
Force factor [Bl]	3.5 Tm
Mechanical resistance [Rms]	0.41 kg/s
Moving mass [Mms]	0.45 g
Compliance [Cms]	0.23 mm/N
Effective diaph. diameter [D]	33 mm
Effective piston area [Sd]	8.5 cm <sup>2</sup>
Equivalent volume [Vas]	0.02 l
Sensitivity (2.83V/1m)	89.5 dB
Ratio Bl/ $\sqrt{Re}$	1.61 N/ $\sqrt{W}$
Ratio fs/Qts	1068 Hz

#### Notes:

IEC specs. refer to IEC 60268-5 third edition.  
All Scan-Speak products are RoHS compliant.  
Data are subject to change without notice.  
Datasheet updated: April 30, 2013.

#### Electrical Data

Nominal impedance [Zn]	6 $\Omega$
Minimum impedance [Zmin]	5.7 $\Omega$
Maximum impedance [Zo]	34.6 $\Omega$
DC resistance [Re]	4.7 $\Omega$
Voice coil inductance [Le]	0.01 mH

#### Power Handling

100h RMS noise test (IEC 17.1)*	225 W
Long-term max power (IEC 17.3)*	460 W

\*Filter: 2. order HP Butterworth, 2.8 kHz

#### Voice Coil & Magnet Data

Voice coil diameter	28 mm
Voice coil height	3.3 mm
Voice coil layers	2
Height of gap	2.5 mm
Linear excursion	$\pm 0.4$ mm
Max mech. excursion	$\pm 1.5$ mm
Unit weight	0.7 kg



# TWEETER

# D2905/970000

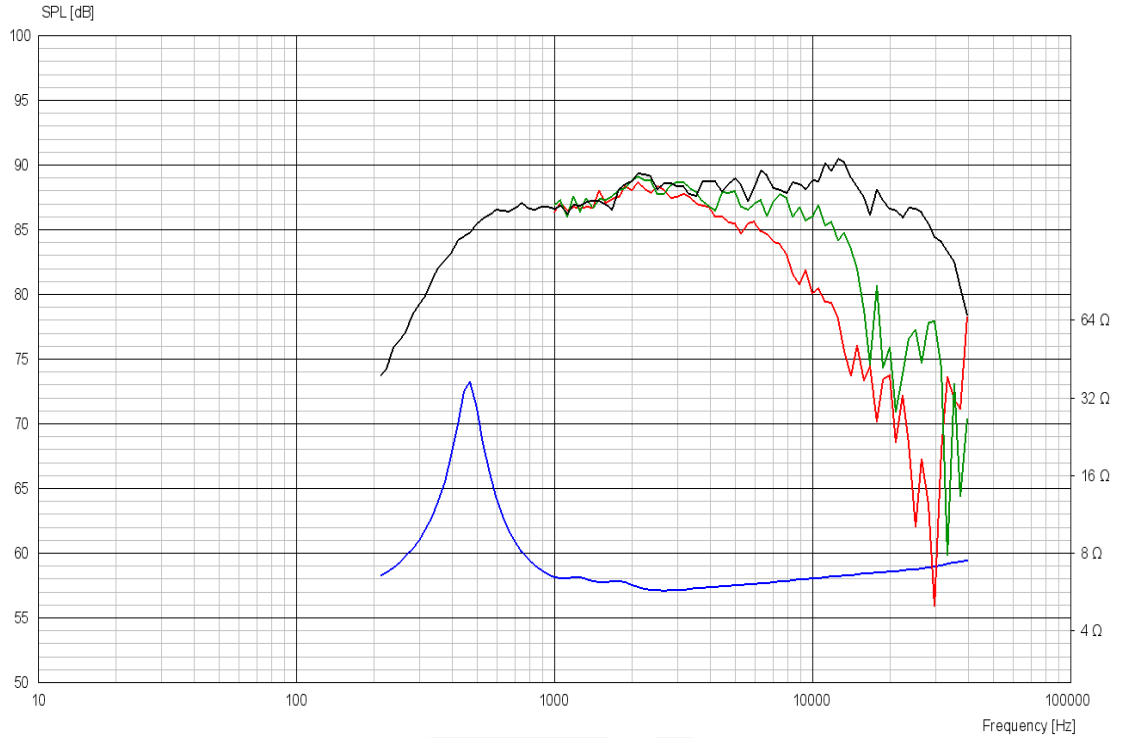

## Advanced Parameters (Preliminary)

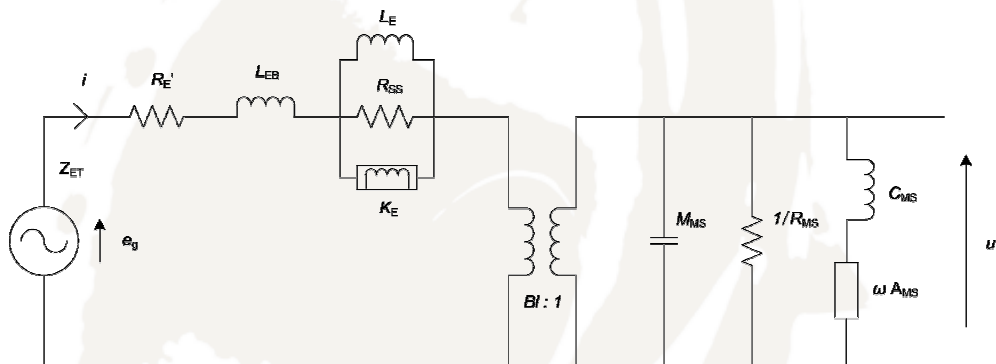

### Electrical data

Resistance [Re']	- Ω
Free inductance [Leb]	- mH
Bound inductance [Le]	- mH
Semi-inductance [Ke]	- SH
Shunt resistance [Rss]	- Ω

### Mechanical Data

Force Factor [Bl]	- Tm
Moving mass [Mms]	- g
Compliance [Cms]	- mm/N
Mechanical resistance [Rms]	- kg/s
Admittance [Ams]	- mm/N