

6.5" Woofer

PURE SOUND

Long Stroke driver with
Ultra Low Distortion and
High SPL Handling



PTT6.5W04 DATA SHEET

- ⊙ Negligible Force Factor Modulation and Surround Radiation Distortion
- ⊙ Low Magnetic Hysteresis Distortion
- ⊙ "Real" long-stroke performance: distortion remains low over full excursion
- ⊙ Uncompromised midrange performance

KEY SPECIFICATIONS

| | |
|------------------------------|-----------------------|
| Driver size | 6.5" |
| DC resistance, R_{DC} | 3.6 Ω |
| Resonance freq., f_s | 30 Hz |
| Total Q factor, Q_{ts} | 0.29 |
| Effective piston area | 133 cm ² |
| Equivalent volume, V_{as} | 26 L |
| SPL@2.83V _{rms} /1m | 88.5 dB |
| Linear X_{max} | +/- 10.0 mm |
| Mechanical X_{max} | +/- 14.5 mm |
| IEC Power handling | 350 W |
| Cone material | Proprietary Fibre Mix |

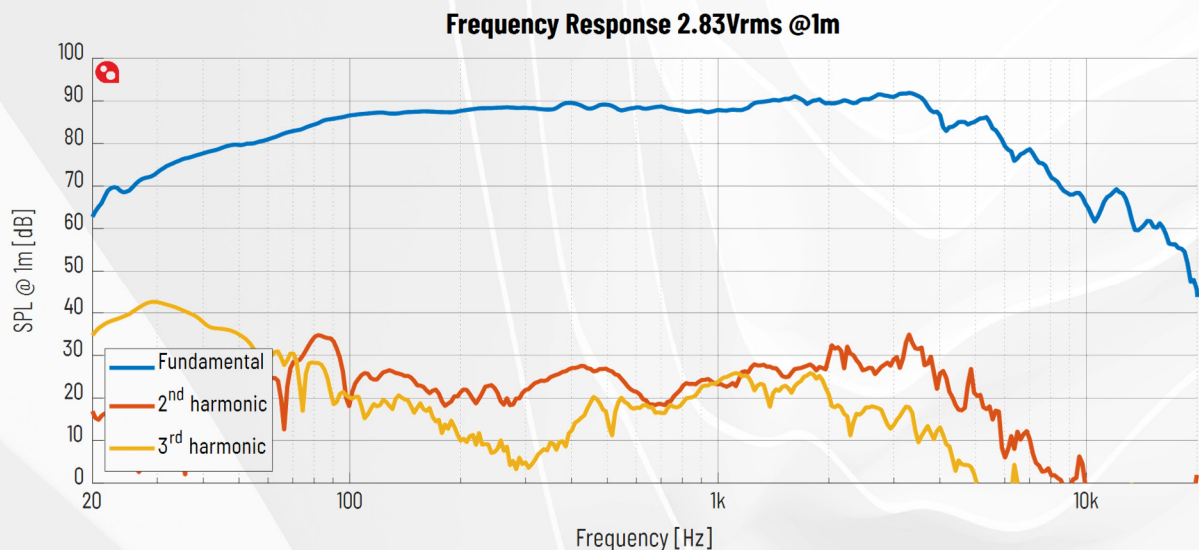

1 Specifications

1.1 Electrical & Acoustical Parameter

| Parameter | | Typ | Unit |
|-----------|---|------|----------|
| Z_n | Nominal impedance | 4 | Ω |
| Z_{min} | Minimum impedance | 4.2 | Ω |
| Z_o | Maximum impedance | 130 | Ω |
| R_{DC} | DC resistance | 3.6 | Ω |
| L_e | Voice Coil inductance @ 1kHz 0mm | 0.37 | mH |
| SPL | SPL@2.83V _{rms} /1m, 300Hz-800Hz, ref. 20 μ Pa | 88.5 | dB |
| | SPL@1W(Z_{min})/1m, 300Hz-800Hz, ref. 20 μ Pa | 85.7 | dB |

Table 1 Electrical & Acoustical Parameters

1.2 T/S & Lumped Parameters

| Parameter | | Typ | Unit |
|-----------|---------------------------|-------|-----------------|
| f_s | Resonance frequency | 30 | Hz |
| Q_{ms} | Mechanical Q factor | 9.0 | - |
| Q_{es} | Electrical Q factor | 0.30 | - |
| Q_{ts} | Total Q factor | 0.29 | - |
| Bl | Force factor | 7.7 | N/A |
| R_{ms} | Mechanical resistance | 0.56 | kg/s |
| M_{ms} | Moving mass | 26.4 | g |
| C_{ms} | Suspension compliance | 1.04 | mm/N |
| S_d | Effective piston area | 132.7 | cm ² |
| D | Effective piston diameter | 13.0 | cm |
| V_{as} | Equivalent volume | 26.0 | L |

Table 2 T/S & Lumped Parameters

1.3 Mechanical Properties

| Parameter | | Typ | Unit |
|------------------------------|--------------------------------|----------|------|
| Excursion Properties | | | |
| X_{max} | Linear excursion | +/- 10.0 | mm |
| | Mechanical excursion | +/- 14.5 | mm |
| Physical Dimensions | | | |
| | Basket diameter | 176 | mm |
| | Cutout diameter | 145 | mm |
| | Mounting hole pattern diameter | 166 | mm |
| | Mounting hole diameter | 5.1 | mm |
| | Magnet diameter | 100 | mm |
| | Outer flange height | 3.5 | mm |
| | Build-in depth | 85.2 | mm |
| Voice Coil Properties | | | |
| | VC diameter | 39 | mm |
| | VC length | 23.7 | mm |
| | VC layers | 4 | - |
| | Airgap height | 4 | mm |
| | Winding material | CCAW | - |

Table 3 Mechanical Properties

1.4 Power Handling

| Parameter | | Typ | Unit |
|-----------|---|-----|------|
| | Long term maximum power (IEC268-5 18.2) | 350 | W |
| | Rated noise power, 100h (IEC268-5 18.4) | 100 | W |

Table 4 Power Handling

1.5 Typical Performance, Graphs

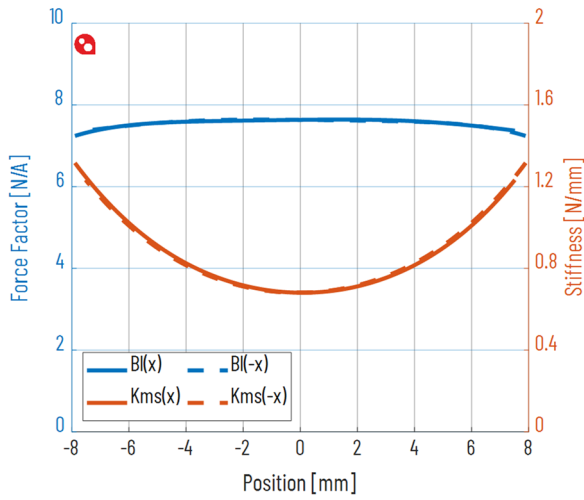

Figure 1 Force Factor and Stiffness vs Voice Coil Position

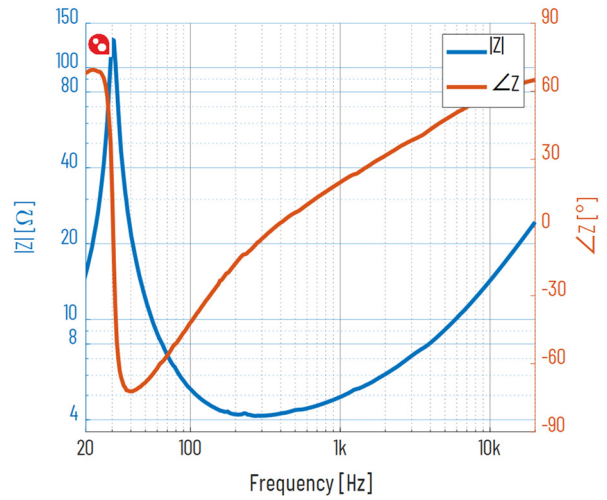

Figure 2 Impedance Response @ 0.5V

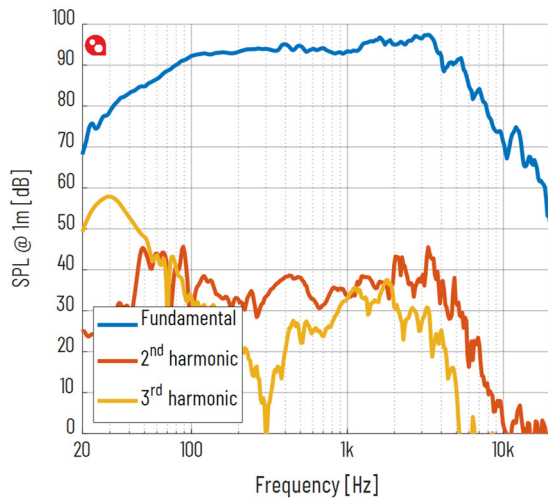

Figure 3 Frequency Response @ 1m, 94dB

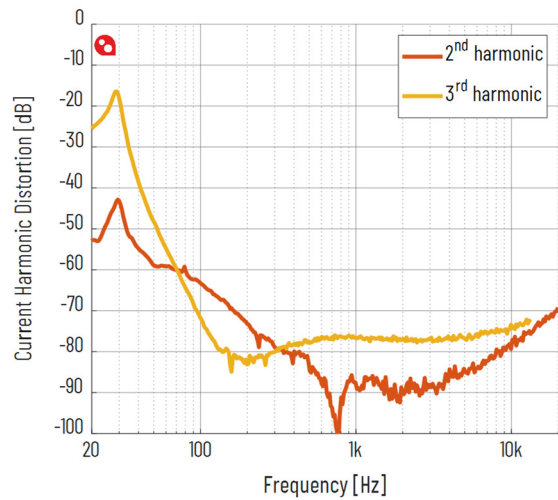

Figure 4 Current Harmonic Distortion Ratio @ 2.83Vrms

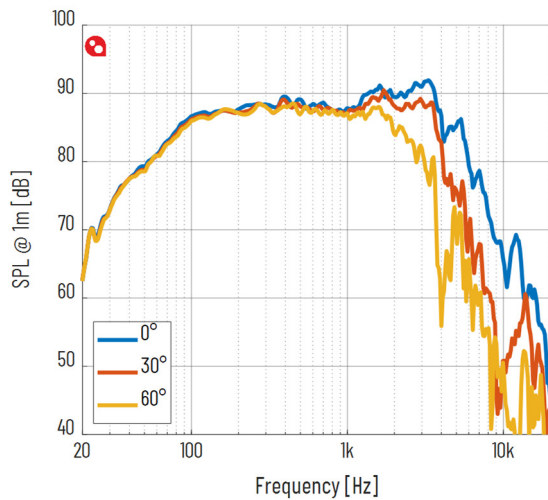

Figure 5 Axial Frequency Response @ 1m, 2.83Vrms

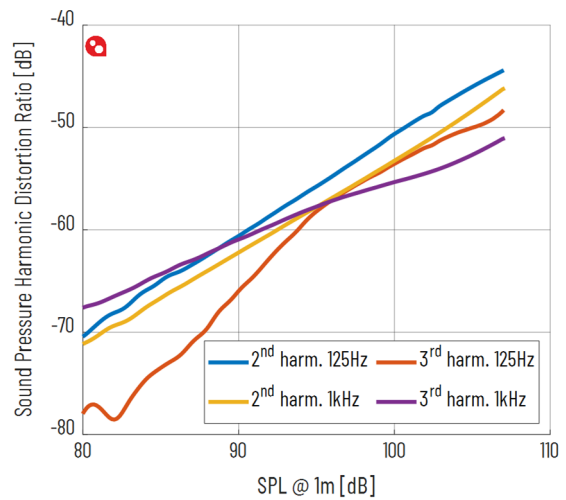
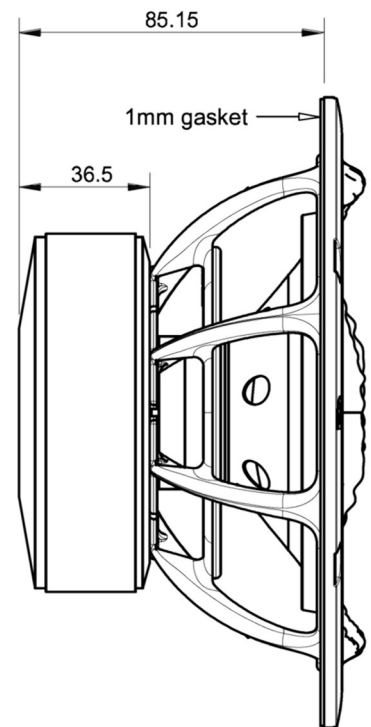
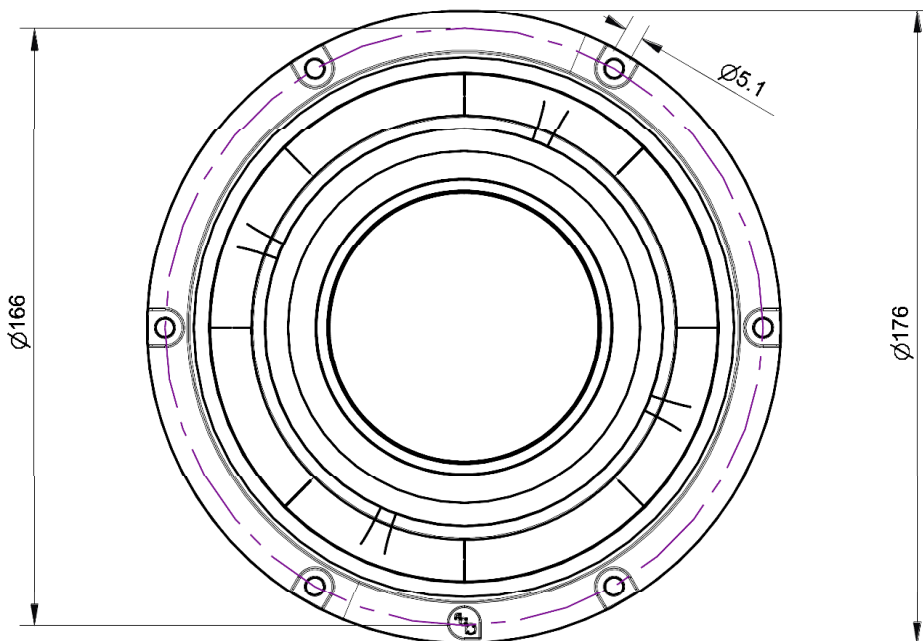
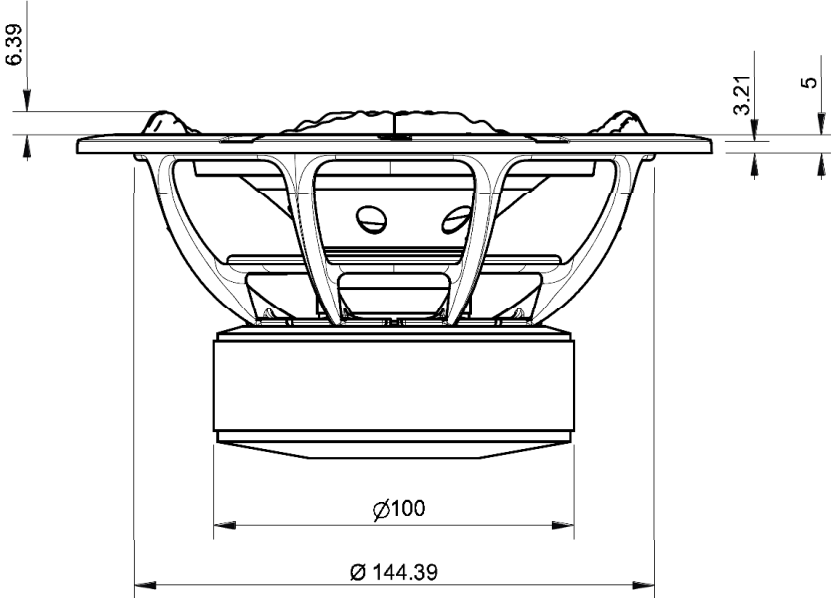

Figure 6 Sound Pressure Harmonic Distortion @ 1m, 0-28.3Vrms

2 Drawings



3 Description

The PTT6.5W04 is a 6.5" driver that truly cracks the long-stroke code. PURIFI's research has identified the parameters that have so far prevented long stroke drivers from breaking through in truly high performance audio. The distortion of the acoustic output of a driver is a combination of several separate distortion mechanisms in the motor, cone and suspension. When testing a complete driver with sine waves, a situation often arises where a small tweak seemingly improves harmonic distortion (HD) by letting two mechanisms counteract each other. This always leads to a clear worsening of intermodulation distortion (IMD) that becomes obvious when testing the unit with a more complex signal. This is why traditional HD tests fail to predict subjective sound quality.

PURIFI takes care to optimize the various distortion mechanisms separately, thus guaranteeing that any measured improvement truly reflects a real audible improvement no matter what the signal is. Accurate mathematical models are developed for the motor, suspension and the vibroacoustics of the dome and surround. These models clearly explain several distortion mechanisms in each domain, which provides fundamental insights into better ways of constructing the motor, cone and suspension. Finally, the same models are used to numerically fine-tune the geometry. This way of working reliably reduces multiple distortions mechanisms which secures low IMD for complex signals.

- **Low Force Factor Modulation**
 - Prevents voice coil current from modulating Force Factor (Bl). The PURIFI motor completely avoids this classical Achilles' heel of long stroke drivers. This translates into low intermodulation (IMD): clean, undistorted midrange even in the presence of a heavy bass.
 - Equates to low impedance modulation, meaning that drive current is not distorted by cone motion.
- **Very Constant Force Factor over Excursion**
 - Prevents voice coil position from modulating the force factor. This is the classical cause of "burbling" i.e. amplitude modulation of the midrange by large low-frequency cone excursions.
- **Low Surround Radiation Distortion**
 - The surround contributes to sound output. Conventional surrounds produce distortion as they deform. PURIFI's Neutral Surround geometry avoids this mechanism without constraining motion. This reduces harmonic distortion as well as intermodulation distortion.
- **Low Magnetic Hysteresis Distortion**
 - Hysteresis means that magnetic domains in iron retain traces of previous magnetization/demagnetization cycles which cause distortion when magnetized or demagnetized again. This distortion masquerades as benign harmonic distortion when tested with a sine wave but takes on a crackling or noisy character with more complex signals.
 - Removing hysteresis distortion translates into a very "fluid" presentation with excellent front/back separation in the stereo image and a perfectly black background between instruments.
- **Cleaner than large-cone short-stroke drivers**
 - The combination of the above characteristics results in a compact long-stroke driver that delivers complex sound with a clarity and lack of effort that was previously the exclusive province of large-area short-stroke drivers. Additionally, thanks to the small cone size, the driver has excellent mid-range reproduction. It is highly suited for two-way systems.

Accuracy of Information: To the extent PURIFI ApS provides information on function and specifications, PURIFI ApS attempts to be as accurate as possible. However, PURIFI ApS does not warrant the accuracy of information on its website and other documents as accurate, complete, reliable, current, or error-free. All data and information in the Data Sheet are subject to change.