

ICEpower500A

500W General Purpose ICEpower Amplifier

Version 2.2

Contents

General Description.....	2
Block Diagram	3
Connection Diagram.....	3
Absolute Maximum Ratings.....	5
Electrical Specifications.....	5
Timing Specifications	6
Typical Performance Characteristics.....	6
Application Information.....	9
Operational Timing Diagram	11
Features	12
Thermal Design	14
Power Supply	14
Physical Dimensions	15
Contact	16
Legal Notes	16

General Description

The ICEpower500A is a general purpose amplifier solution. By using patented, state-of-the-art ICEpower® analogue technology, the ICEpower500A achieves extremely high fidelity in a compact package.

The full audio bandwidth and the ability to operate from a variety of power sources means the ICEpower500A can be used in:

- Active speakers and subwoofers
- A/V amplifiers/receivers
- Automotive amplifiers
- Musical instrument amplifiers
- Marine audio products
- Installation audio products



Figure 1: ICEpower500A
Size: 9 x 9 x 2.7cm

True high-end performance is guaranteed by the patented, proprietary COM modulation and MECC control techniques and the integrated, turn-key design reduces design-in cost and shortens Time-to-Market for the end product.

Key Specifications

- 500W @ 0.02% THD+N, 1 kHz, 4Ω.
- Peak output current > 45A.
- 117dBA dynamic range.
- THD = 0.0009% @ 100mW, 5kHz.
- THD+N < 0.1%, 0.1W – 500W, 4Ω.
- Efficiency = 93% @ 300W /8Ω.
- Output impedance < 5mΩ @ 1kHz.
- Power Supply Rejection Ratio >60dB.
- Output DC-offset < 25mV.

Key Features

- Very rugged design for demanding use
- Soft mute/de-mute
- Stand-by mode for low power consumption
- Under voltage protection
- Monitor output
- Balanced input and output
- Excellent EMI performance
- No heat sink required
- Safety: IEC 60065 ed. 8.

Document History

Version	Date	Revised by	Description
2.2	15-01-2018	DIT	Address updated Legal Notes updated Document History added

Block Diagram

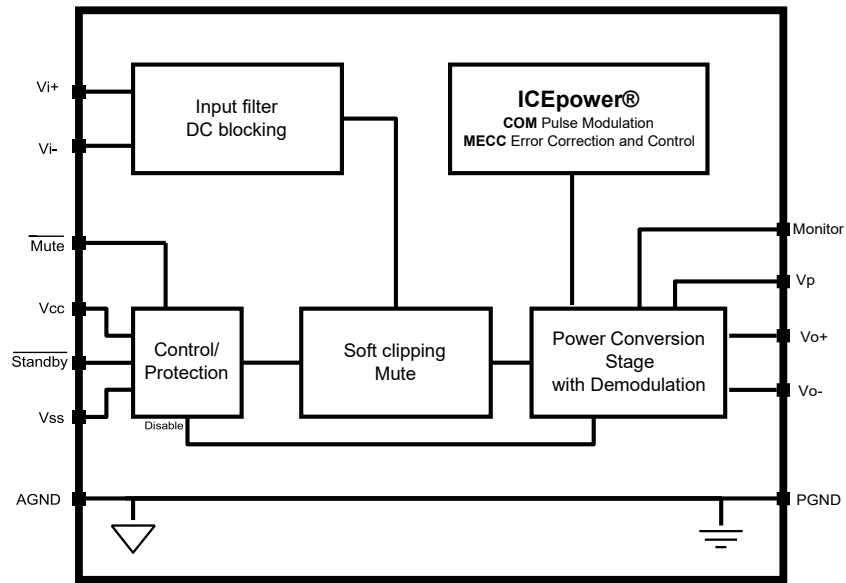

Figure 2: ICEpower500A block diagram.

Connection Diagram

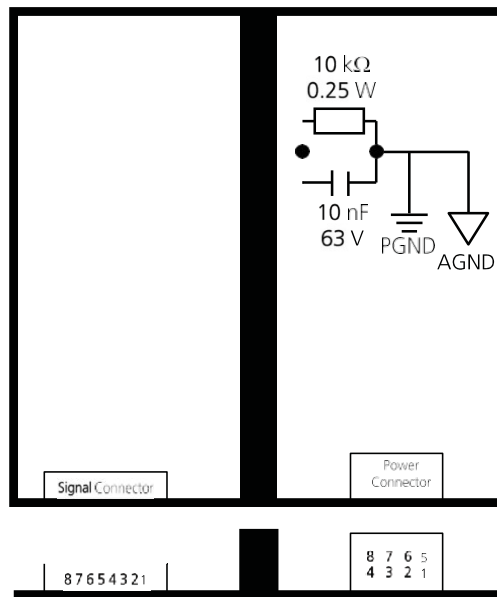

Figure 3: ICEpower500A-IC connections.

The plug interface of the ICEpower500A has two industry standard connectors selected for long-term reliability. The power Molex Micro-Fit™ connector is used for power input and speaker output. The JST PH-connector is used for low level power supply, audio input and the control features.

Power Connector Specification

Pin	Function	Description
7, 8	PGND	Power GND for the single ended power supply input V_p .
3, 4	V_p	Power Supply (single) for the power stage
1, 2	V_{o-}	“ Cold ” balanced power output terminals. In phase with V_{i-}
5, 6	V_{o+}	“ Hot ” balanced power output terminals. In phase with V_{i+}

Table 1: Power Connector Specifications.

Signal Connector Specification

ICEpower* Pin numbering	Function	Description	JST** Pin numbering
1	Vcc	Positive power supply input for the signal section.	8
2	Vss	Negative power supply input for the signal section.	7
3	AGND	Ground terminal for the signal section.	6
4	Monitor	Unbalanced attenuated output signal.	5
5	V_{i+}	Positive input (balanced input buffer).	4
6	V_{i-}	Negative input (balanced input buffer).	3
7	Mute	Mute input (Internal pull-up).	2
8	Standby	Control pin for standby control. (Internal pull-up).	1

* This pin numbering is used by ICEpower in all ICEpower documentation

**This pin numbering is used by JST- JST is the manufacturer of the PHR-08 connector.

Table 2: Signal Connector Specification.

Absolute Maximum Ratings

Absolute maximum ratings indicate limits beyond which damage may occur.

Symbol	Parameter	Value	Unit
V _p	Operating power supply level	85	V
V _{cc}	Positive analog supply	15	V
V _{ss}	Negative analog supply	-15	V
V _{in}	Maximum differential input voltage	±12	V
T _{case}	Maximum case temperature	90	°C
T _a	Maximum operating ambient temperature	60	°C
R _{th, case-rib}	Thermal resistance, case – rib	2	K/W
T _{ZOBEL} ¹⁾	Maximum duration of 25V _{RMS} output @ 20kHz	30	s
C _L	Maximum pure capacitive loading	470	nF

Table 3: Absolute Maximum ratings.

1) The output RC-Zobel network is designed for music loads. Continuous stress at frequencies above 10 kHz may damage the device.

Electrical Specifications

Unless otherwise specified, f=1kHz, P_O=1W, T_a= 25 °C.

Symbol	Parameter	Conditions	Min	Typ	Max	Unit
V _p	Power Supply	Operation	42	75	80	V
V _{cc}	Positive analog supply	Operation	10	12	15	V
V _{ss}	Negative analog supply	Operation	-10	-12	-15	V
P _O	Output power @ 0.1%THD+N 10Hz < f < 20kHz (AES17 measurement filter) ²⁾	R _L = 4Ω. V _p = 75V R _L = 8Ω. V _p = 80V		500 220		W
THD+N	THD+N in 4Ω (AES17 measurement filter) ²⁾	f = 1kHz, P _O =1W		0.006	0.01	%
THD+N	Maximal THD+N in 4Ω (AES17 measurement filter) ²⁾	10Hz < f < 20kHz 100mW < P _O < 500W		0.1	0.12	%
I _{Vp}	Quiescent current	V _p = 75V	20	25	30	mA
I _{Vp, standby}	Standby current	V _p = 75V		1.6		mA
I _{Vcc}	Quiescent current	V _{cc} = 12V		200		mA
I _{Vcc, standby}	Standby current	V _{cc} = 12V		54		mA
I _{Vss}	Quiescent current	V _{ss} = -12V		25		mA
I _{Vss, standby}	Standby current	V _{ss} = -12V		25		mA
f _o	Offset switching frequency	Idle	420	460	500	kHz
f _s	Switching frequency range	Idle to full scale variation	60		500	kHz
η	Power stage Efficiency	R _L = 8Ω, P _O = 300W		93		%
PSRR	Power Supply Rejection Ratio of V _p	Voltage ripple @, f = 100 – 120 Hz	60			dB
V _{N,O}	Output referenced idle noise	A-weighted 10Hz < f < 20kHz	65	75	115	μV
V _{OFF,Diff}	Differential offset on output terminals	Input terminated.			±25	mV
V _{OFF,CM}	Common mode offset on output terminals	Input terminated.		V _p / 2	±10%	V
A _V	Nominal Voltage Gain	f = 1 kHz	26.8	27.1	27.4	dB
f	Frequency response	20Hz - 20kHz, All loads		±0.5	±1.0	dB
f _u	Upper bandwidth limit (-3dB)	R _L = 8Ω		60		kHz
f _l	Lower bandwidth limit (-3dB)	R _L = 8Ω		4		Hz
Z _o	Abs. output impedance	f = 1kHz		5	10	mΩ
Z _L	Load impedance range		2	4	≡	Ω
D	Dynamic range	A-weighted		117		dB
IMD1	Intermodulation (CCIF)	f = 19kHz, 20kHz, P _O =10W		0.002	0.001	%
IMD2	Intermodulation (SMPTE)	f = 60Hz, 7kHz(1:4), P _O =10W		0.02	0.03	%
TIM	Transient intermodulation (TIM)	f ₁ = 3.15kHz square, f ₂ = 15kHz, P _O =10W		0.003	0.005	%

Table 4: Electrical Specifications.

2) AES17, 22kHz 7th order Audio Precision measurement filter is used.

Timing Specifications

Symbol	Parameter	Conditions	Min	Typ	Max	Unit
t_{sd}	Switching start up delay	Time from when all power supplies ³⁾ are within operational limits	200	250	300	ms
t_{pdm}	Output delay	Time delay to signal ³⁾	350	400	500	ms
t_{md}	Mute delay	Time delay to mute ³⁾	30	50	100	ms
t_{dmd}	De-mute delay	Time to demute ³⁾	300	350	400	ms
t_{psd}	Shutdown delay	Supply failure or Standby pin ³⁾		1	5	μ s

Table 5: Timing Specifications.

3) For details see Figure 12 and Figure 13.

Typical Performance Characteristics

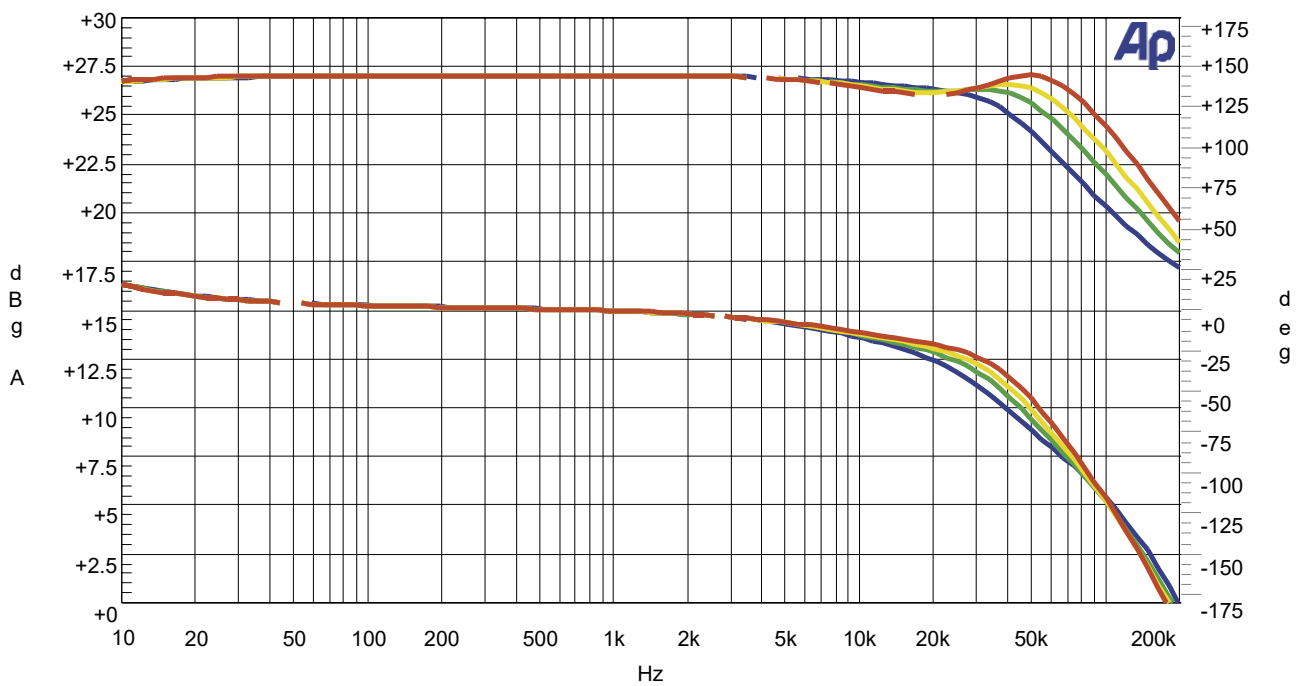

Figure 4: Frequency response in 4Ω, 8Ω, 16Ω and open load. Top – amplitude. Bottom – phase.

Efficiency vs. Output Power

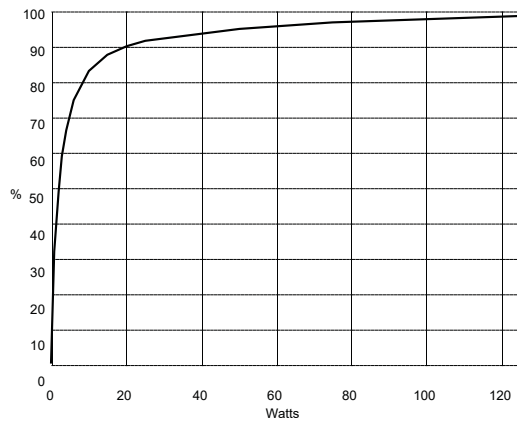

Figure 5: Efficiency vs. output power (16Ω).

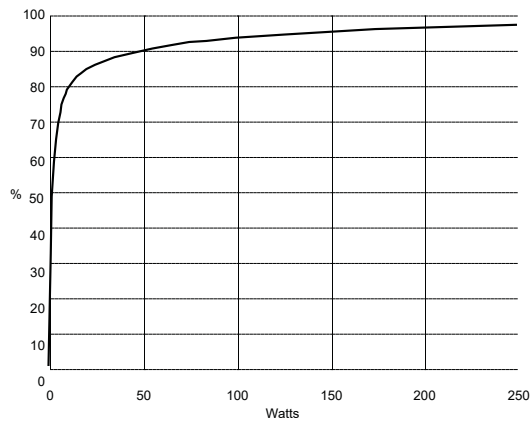

Figure 6: Efficiency vs. output power (8Ω).

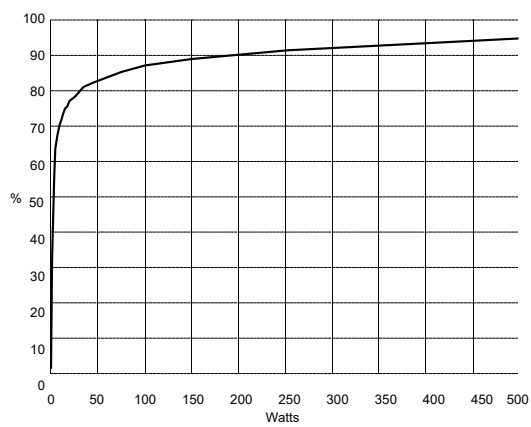
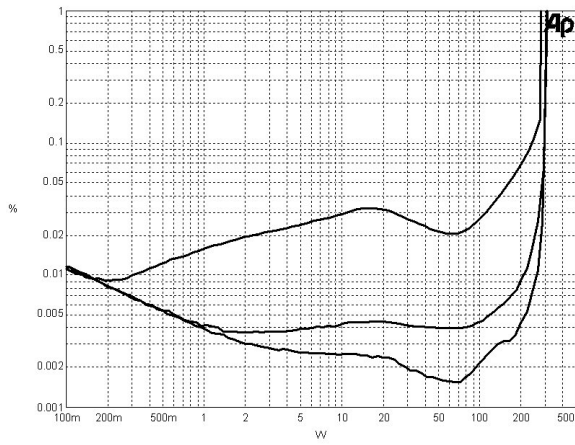
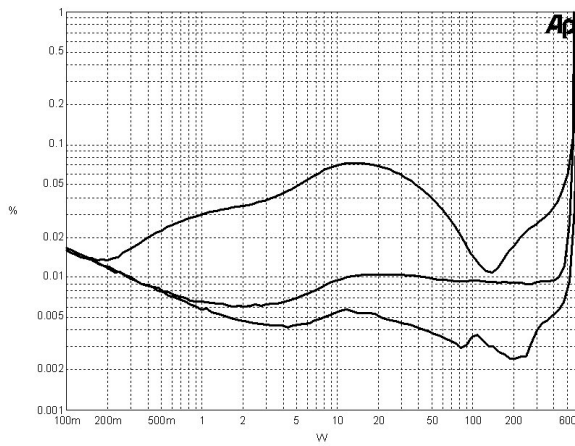

Figure 7: Efficiency vs. output power (4Ω).

Harmonic Distortion & Noise



THD+N vs. output power at 100Hz, 1kHz and 7kHz⁴⁾ (8Ω).



THD+N vs. output power at 100Hz, 1kHz and 7kHz⁴⁾ (4Ω).

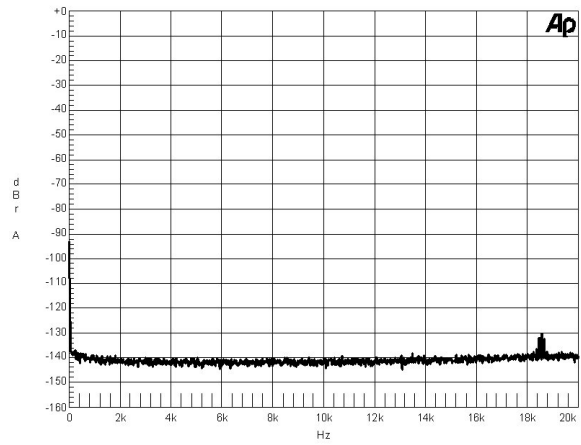

Idle noise (16K FFT). Residual = 75μV(A).

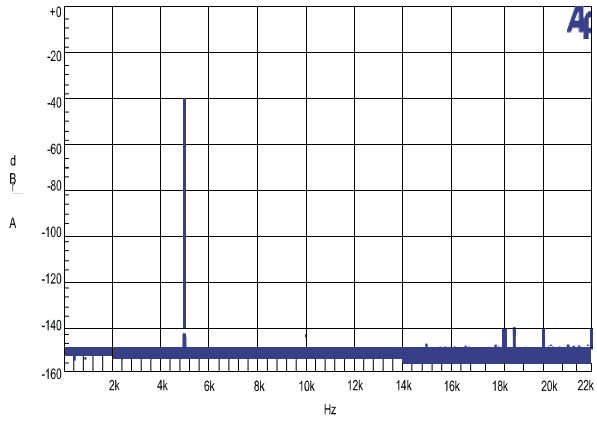

FFT Analysis. f = 5kHz/100mW 4Ω loading. THD = -101dB (0.0009%)

Figure 8: Harmonic Distortion & Noise.
4) AES17, 22kHz 7th order Audio Precision measurement filter is used.

Application Information

To simplify product development, the ICEpower500A is designed as a “complete” component electrically and mechanically. A typical ICEpower500A component application is a single channel application (e.g. an active speaker system). An example is shown in Figure 9.

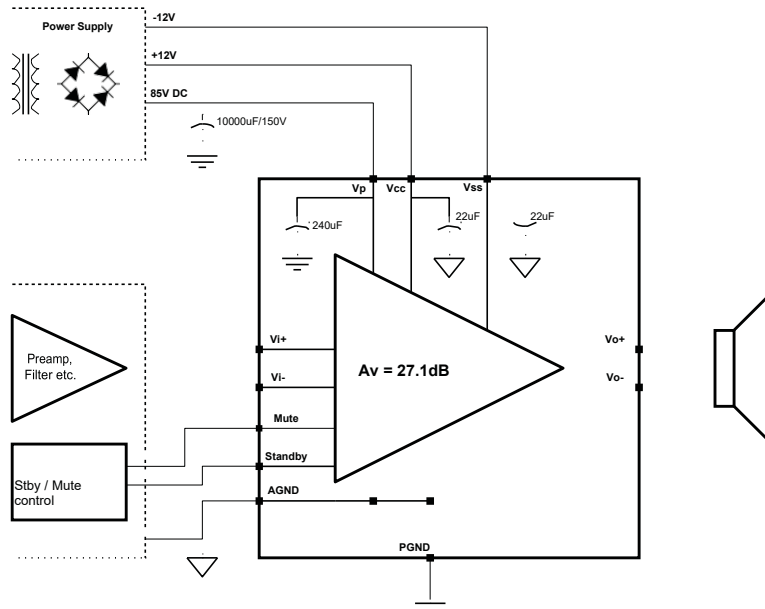

Figure 9: Typical application.

Input/Output Interfaces

The balanced input section provides signal buffering and anti-alias filtering. The balanced configuration helps to avoid hum and noise pick-up. If an unbalanced input be preferred this can be set by shorting Vi- and AGND.

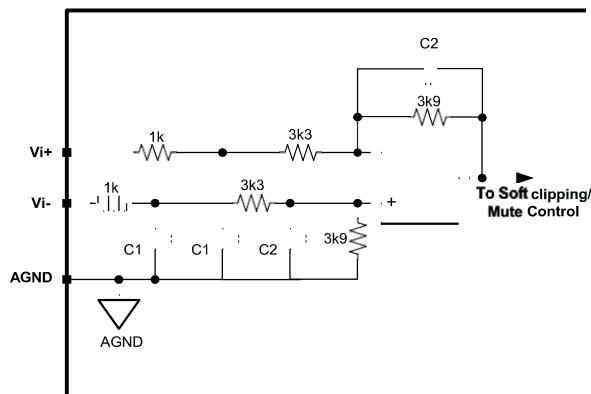

Figure 10: Balanced input buffer / anti-aliasing filter.

The anti-aliasing filter bandwidth is 100 kHz and the filter characteristics are shaped to match the power amplification section. The audio bandwidth is 60 kHz and the input impedance is approximately 8kΩ over the audio bandwidth. This presents an acceptable load for most pre-amps, active crossover outputs etc.

Output Stage

The output stage is a bridge topology with a 2nd order filter. This leads to a balanced power output on the terminals Vo+ and Vo-. The filter design is a part of the proprietary MECC topology and has been chosen as a compromise between demodulation, efficiency and filter volume.

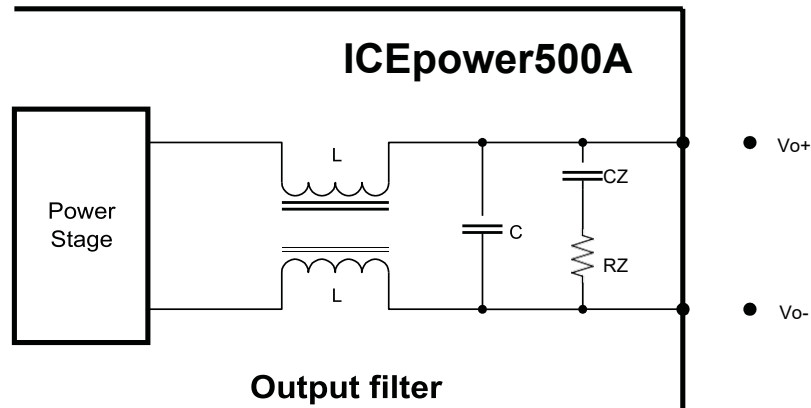

Figure 11: Output filter section with compensating Zobel network.

The essential output characteristics are:

- The output impedance is below $25\text{m}\Omega$ @ 20 kHz.
- The output residual basically consists of a single frequency component at the carrier fundamental of approximately 460 kHz. In a standard application set-up, the output characteristics lead to compliance with the EN and FCC directives on EMI.
- The system bandwidth is 70 kHz with an 8Ω load.

The ICEpower500A is designed to have low output impedance at all frequencies (see Figure 4) and thus be unaffected by loading characteristics. Care should however be taken with *purely* capacitive loads. The ICEpower500A is designed to be stable with purely capacitive loads up to 470nF. Higher capacitive loads may compromise stability and thus damage the device.

Warning! The balanced speaker outputs are both “hot” with a common-mode DC level equal to $V_p/2$. Always use balanced probes for monitoring and measurements. Shorting one of the terminals to ground results in an over current situation. As the module has no internal current limiter even a brief short circuit (phase-to-phase or phase-to-GND) will damage the device beyond repair. Current limiting circuitry must be connected externally.

Operational Timing Diagram

The power supply input pins, the Standby pin and the Mute pin control the ICEpower500A. If the supplies are not above their minimum values the amplifier will enter standby mode. The amplifier can be forced into standby mode by pulling the standby pin low. The Mute pin will not stop the switching of the amplifier, but attenuates the output signal by 60dB when pulled low.

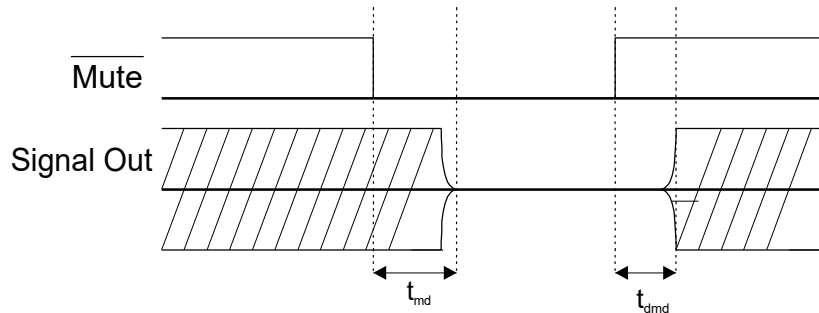

Figure 12: Mute and de-mute timing definitions.

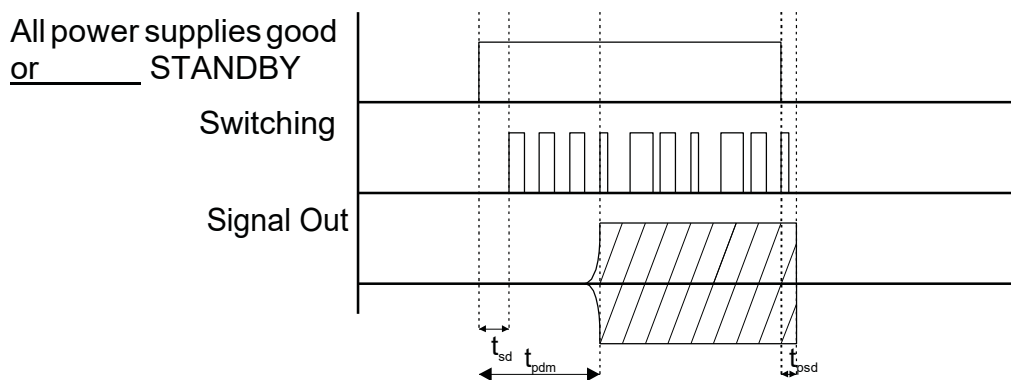

Figure 13: Supply startup and shut down timing definitions.

Power-up Sequence

The power supplies control power-up of the ICEpower500A. When the power supplies reach operational power levels the switching output stage is enabled with a 50% duty-cycle (zero modulation). To ensure power supply stability before start-up, a propagation delay of $t_{sd} = 250\text{ms}$ (typical value) has been introduced. The built-in mute function subsequently releases the input signal with a timed delay of $t_{dmd} = 350\text{ms}$ for a soft, controlled start-up sequence. The total delay from power is applied until full signal amplification is available is thus 600ms.

Power-down Sequence

The module will enter standby mode if:

1. One of the power supplies drops below the minimum acceptable level or falls out completely.
2. The standby pin is pulled low.

In either case the ICEpower500A will shut off instantly ($1\mu\text{s}$) by muting the signal and disabling the output stage. After a power-down, meaning when the standby pin is released and/or the power supplies return to nominal values, the ICEpower500A will power up using the standard power-up sequence as described above.

Features

Mute Control

The mute function has been implemented to allow soft mute/de-mute of the module. The recommended external interface circuit for this pin can be seen on Figure 14. Timing specifications are only valid with the shown interface.

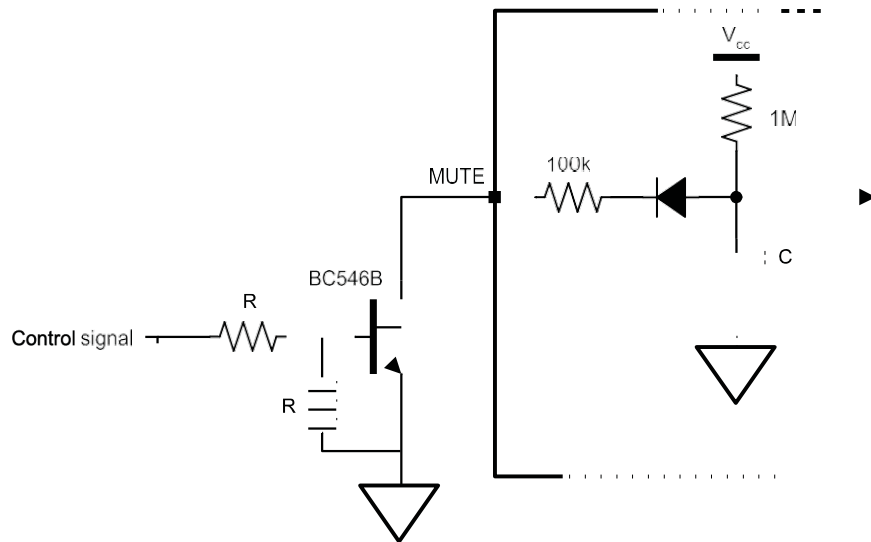

Figure 14: Interface and simplified internal circuit for the MUTE pin.

Standby Control

The Standby pin can be used to put the module in a low power consumption mode. Pulling the standby pin low sets the standby mode. This function allows quick shutdown of the module and can be used for protection of the module. The recommended external circuit is shown in Figure 15. The timing specifications are only valid with the interface circuit shown.

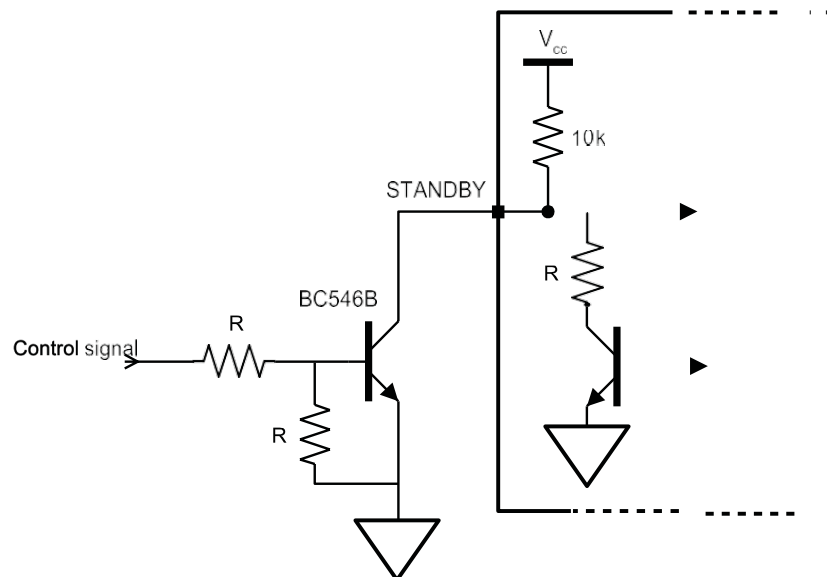

Figure 15: Interface and simplified internal circuit for STANDBY pin.

Monitor Output

The monitor output has been implemented as an attenuated, ground referenced version of the balanced output signal. The internal output circuit of this output is shown in Figure 16. The bandwidth for the monitor output is limited to 45 kHz.

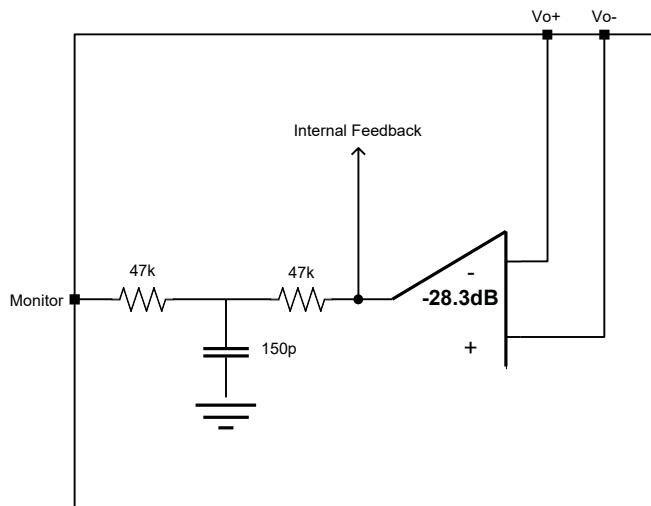

Figure 16: Internal circuitry of the monitor output.

Thermal Design

Thermal design is generally a great challenge in power amplifier systems. Linear amplifier designs operating in class A or AB are normally very inefficient and therefore equipped with extensive heat sinking to keep the transistor junction temperature low. The ICEpower500A is based on highly efficient ICEpower switching technology providing high overall efficiency characteristics at all levels of operation. Refer to the efficiency vs. output power graph in the section “Typical performance characteristics” for more information.

With $R_{th, case-rib} = 2 \text{ K/W}$ the heat sink can be designed using normal thermal design considerations. Mounting the ICEpower500A to an aluminum backplane or enclosure is normally sufficient to ensure trouble-free operation even under continuous loading. Please note that the module relies on both the heat sink and the ambient air for cooling and so it must be ensured that neither T_{case} nor T_a is exceeded during operation. The ICEpower500A has no thermal shutdown feature and a suitable thermal monitoring circuit must be connected externally if the application requires protection against thermal overload.

Power Supply

The ICEpower500A has excellent power supply rejection on the main supply line (V_p) due to the use of ICEpower’s patented COM modulation, and as such there are no specific requirements for power supply stabilization. The ICEpower500A runs well even on an unstabilized supply, linear or switch-mode, with several volts of ripple. The COM modulation technology also means that power supply bypassing and layout are not critical and that poor layouts will not cause stability problems as can be the case in linear amplifier designs.

The analog V_{cc} and V_{ss} supply lines must be regulated. Noise and ripple on these supplies will directly affect overall system performance and voltages exceeding 15V on either line will damage the device.

Physical Dimensions

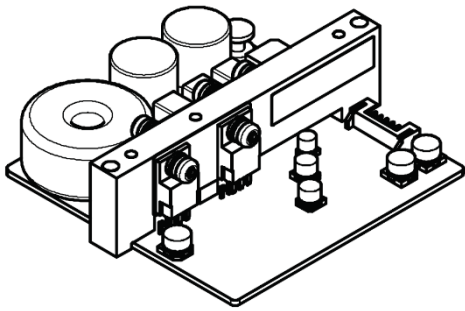

SCALE 1:2

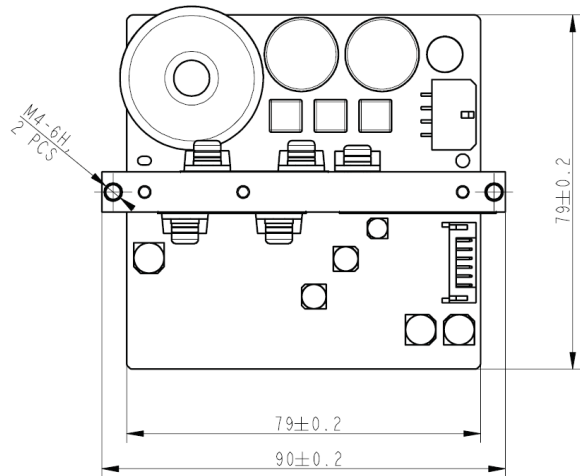
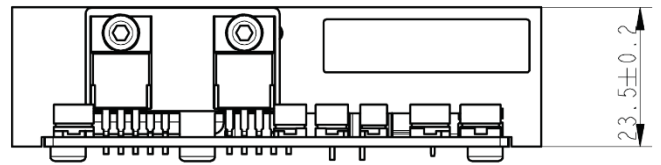
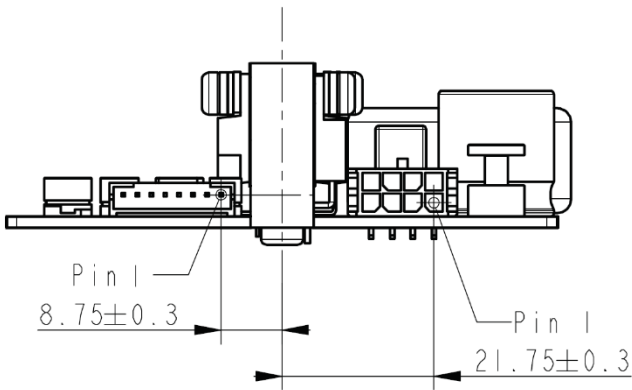
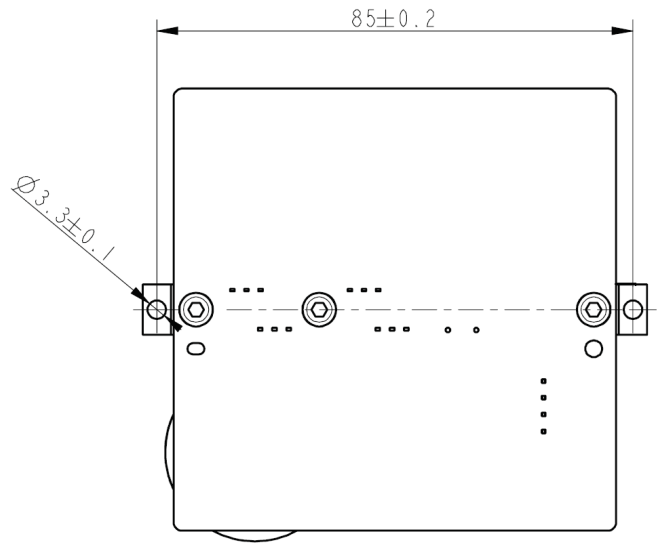

Figure 17: Physical dimensions ICEpower 500A-IC

Contact

For additional information about the ICEpower® technology from ICEpower a/s, visit our web site or contact us.

ICEpower a/s
Vandtårnsvej 62A. 3rd floor B
DK-2860 Søborg
Denmark

www.icepower.dk
info@icepower.dk

Legal Notes

ICEpower a/s believes that the information in this datasheet is accurate and reliable. However it is provided "as is" without any warranties of any kind. ICEpower a/s and its suppliers, to the fullest extent permitted by law, disclaim all warranties, including the warranty of merchantability, warranty of non-infringement of third-party rights, and the warranty of fitness for a particular purpose. ICEpower a/s and its suppliers make no warranties about the accuracy, reliability, completeness, or timeliness of the material, services, software, text, graphics and links. In no event will ICEpower a/s be liable to any party for any damages whether direct, indirect, special, consequential or other for any use or inability to use of this datasheet, including, without limitation, any damages for lost profits, business interruption, loss of programs or other data on your information handling system or otherwise, even if we are expressly advised of the possibility of such damages.

Information in this datasheet may contain technical inaccuracies or typographical errors. The information in the datasheet may be changed at any time without prior notice or obligation.

ICEpower® is a trademark of ICEpower a/s.

ICEpower a/s products are not authorized for use as critical components in life support devices or life support systems without the express written approval of the president and general counsel of ICEpower a/s. As used herein:

- Life support devices or systems are devices or systems which, (a) are intended for surgical implant into the body, or (b) support or sustain life, and whose failure to perform when properly used in accordance with instructions for use provided in the labelling, can be reasonably expected to result in a significant injury to the user.
- A critical component is any component of a life support device or system whose failure to perform can be reasonably expected to cause the failure of the life support device or system, or to affect its safety or effectiveness.

ICEpower a/s ©2016