

ICEpower200ASC

200W ICEpower Amplifier with integrated ICEpower Supply

Version 2.7

Contents

General Description	3
Release Notes.....	4
Block Diagram	5
Connection Diagram.....	5
Absolute Maximum Ratings	7
Power Specifications	9
Audio Specifications	10
General Audio Specifications	11
Electrical Specifications.....	11
Timing Specifications.....	12
Disturbances on the Mains	12
Mechanical Specifications	12

Typical Performance Characteristics	13
Loading	20
Dissipated Power vs. Output Power	20
Features.....	21
Protection Features.....	24
Input/Output Interfaces.....	25
Operational Timing Diagram	26
Thermal Design	27
Physical Dimensions.....	29
Safety Standards	31
EMI Standards	31
ESD Warning.....	31
Packaging and Storing	32
Contact	33
Legal Notes.....	33

General Description

The ICEpower200ASC is a fully integrated, intelligent audio power conversion module designed particularly for highly competitive consumer and professional audio applications. The ICEpower200ASC is pre-approved for EMC and safety and the “black-box” completeness allows for fast design-in and minimized time to market. Key benefits include:

- ICEpower’s patented COM modulation and MECC control techniques ensure excellent audio performance.
- Integrated ICEpower supply with separate AUX converter and standby functionality makes for a compact, turnkey power solution.
- A comprehensive set of features for plug-and-play implementation in a wide range of applications such as active speakers/subwoofers, HTIB, and A/V amplifiers/receivers.
- Compliance with 2013 regulatory standby requirements 1275/2008/EC step II and Energy Star®, with 0.25W@230V_{AC} standby current consumption with no payload.

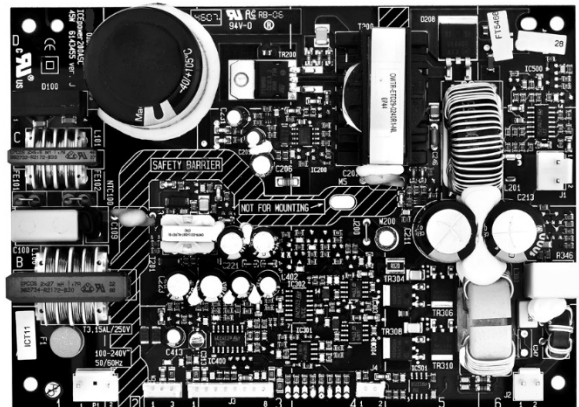

The ICEpower200ASC is an integrated power solution which completely eliminates the need for heat sinks and EMI shields. The ICEpower200ASC also provides an auxiliary +/-12V supply for external signal conditioning circuitry and the DC-bus output for powering additional ICEpower200AC amplifiers makes designing compact multi-way or multi-channel solutions easy.

Key Specifications

- 200W @ 0.2% THD+N (10Hz – 20kHz, 4Ω)
- 110dBA dynamic range @ 200W, 4Ω
- Max output voltage / current: 43V_p / 12.5A_p, 4Ω
- THD+N = 0.006% (1W, 8Ω, 1kHz)
- THD+N < 0.2% (0.1W – 200W, 4Ω)
- 79 % total efficiency @ 200W, 4Ω
- CCIF Intermodulation distortion = 0.0005% (10W, 4Ω, 14kHz/15kHz)
- Damping factor = 4000 (100Hz, 8Ω)
- Stand-by power consumption 0.25W@230 V_{AC}

Key Features

- Rugged construction
- Suitable for CE and FCC approved designs
- ±12V auxiliary DC output
- Universal mains 85-264V_{AC}
- Thermal protection
- Over current protection
- DC output protection
- Sound optimized soft clipping
- EMI conforms to: EN55013 and others.
- Safety conforms to: UL60065, 62368 and others

Release Notes

Version	Date	Revised by	Changes
2.5	2017-09-19	LBH / DIT	Output voltage / current spec. added Safety and EMI standards updated Address updated Legal Notes updated
2.6	2019-09-19	ASP / LBH	Output voltage / current spec. with AUX added
2.7	2020-07-01	NKK	Safety update

Block Diagram

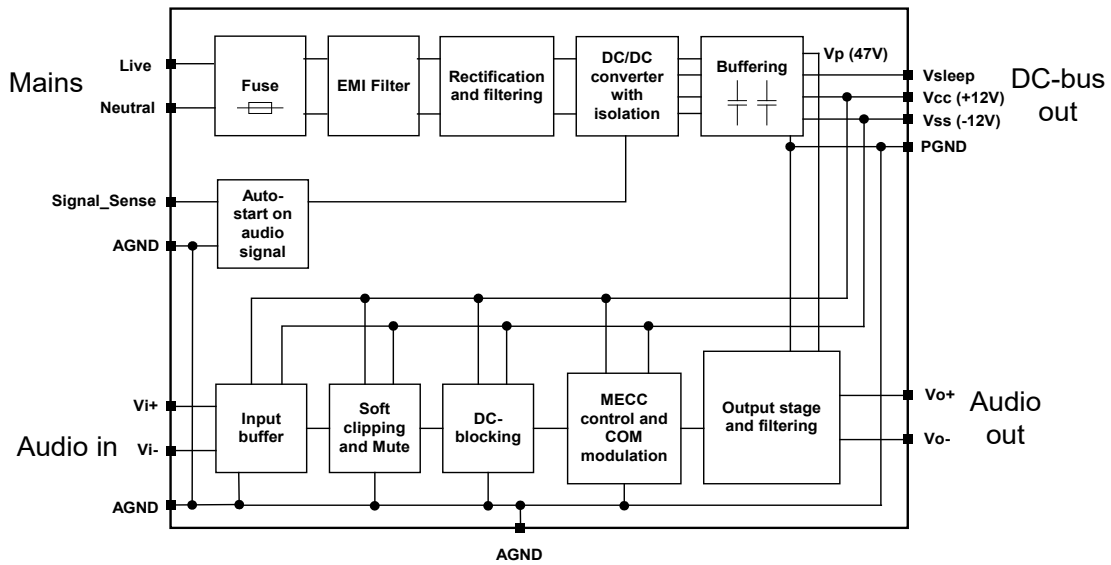

Connection Diagram

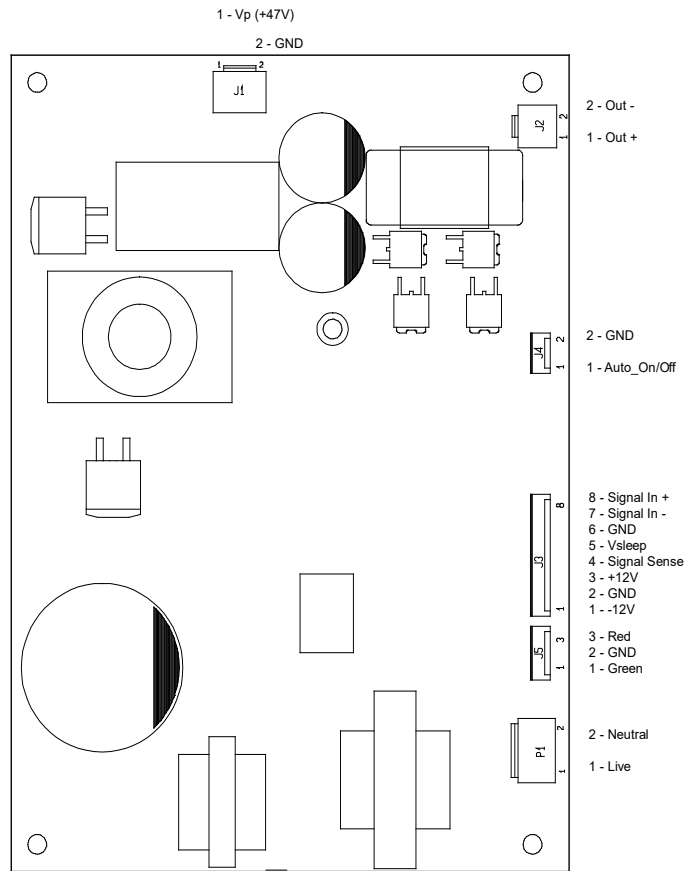

Figure 1: ICEpower200ASC connections

The plug interface of the ICEpower200ASC modules has five industry standard connectors selected for long-term reliability.

AC header specification (P1)

Type: B2P3-VH (LF)(SN)			
PIN	Function	Description	Type
1	Live	Live AC	Input
2	Neutral	Neutral AC	Input

Table 1: AC connector specification

DC-bus header specification (J1)

Type: JST B2P-NV			
PIN	Function	Description	Type
1	Vp (47V)	Power supply +47V	Output
2	GND	Ground terminal for the power section	Output

Table 2: Speaker connector specifications.

Speaker header specification (J2)

Type: JST B2P-VH			
PIN	Function	Description	Type
1	Vo+	“Hot” balanced audio power output terminal.	Output
2	Vo-	“Cold” balanced audio power output terminal.	Output

Table 3: Speaker connector specifications.

Signal header specification (J3)

Type: JST B8B-EH-A			
PIN	Function	Description	Type
1	Vss (-12V)	Power supply -12V	Output
2	GND	Ground terminal for the signal section.	Output
3	Vcc (+12V)	Power supply +12V	Output
4	Signal Sense	Control pin for start up when signal present.	Input
5	Vsleep	Low power standby supply	Output
6	GND	Ground terminal for the signal section.	GND
7	Vi-	Negative input (balanced input buffer).	Audio Input
8	Vi+	Positive input (balanced input buffer).	Audio Input

Table 4: Signal connector specification.

Auto start header specification (J4)

Type: JST B2B-EH-A			
PIN	Function	Description	Type
1	Auto Off	Control pin for automatic on/off	Input
2	GND	Ground terminal for the signal section.	GND

Table 5: Auto Start Switch specification.

LED Output header specification (J5)

Type: JST B3B-EH-A			
PIN	Function	Description	Type
1	Green	LED drive for green "On" indicator	Output
2	GND	Ground terminal for the signal section.	GND
3	Red	LED drive for red "Standby" indicator	Output

Table 6: LED Output specification.

Absolute Maximum Ratings

Absolute maximum ratings indicate limits beyond which damage may occur.

Mains input section

Symbol	Parameter	Value	Units
AC_{max}	Maximum off-line voltage	264	V_{AC}
AC_{min}	Minimum off-line voltage	85 ¹⁾	V_{AC}
F	Mains frequency range $85V_{AC} - 264V_{AC}$	45 – 65	Hz

Table 7: Absolute maximum ratings mains input section.

1) The ICEpower200ASC will operate at lower levels but the output power will be reduced. If the off-line voltage is too low the ICEpower200ASC switches off.

DC-bus

Symbol	Parameter	Value	Units
$I_{+12V}^{2)}$	Maximum current draw from Vcc (+12V)	300	mA
$I_{-12V}^{2)}$	Maximum current draw from Vss (-12V)	200	mA
$I_{AUX}^{2)}$	Maximum current draw from Vcc and Vss (sum of I_{+12V} and I_{-12V})	400	mA
I_{sleep}	Maximum current draw from Vsleep	6	mA

Table 8: Absolute maximum ratings DC-bus.

2) The +/-12V outputs are not over current protected. Exceeding these limits may permanently damage the device.

Input section

Symbol	Parameter	Value	Units
Vin+ , Vin-	Maximum voltage range on pin	± 12	V
Auto Off	Maximum voltage range on pin	0 - Vp	V
Signal Sense	Maximum voltage range on pin	± 12	V

Table 9: Absolute maximum ratings input section.

Output section

Symbol	Parameter	Value	Units
R_{load}	Minimum load	3	Ω
C_L	Maximal pure capacitive loading	330	nF

Table 10: Absolute maximum ratings output section.

3) The over current protection will act to protect the amplifier. (See "Protection features")

Thermal section

Symbol	Parameter	Value	Unit
T_a	Max. operating ambient temperature	50	$^{\circ}\text{C}$

Table 11: Absolute maximum ratings thermal section.

Power Specifications

Unless otherwise specified. $T_a=25^{\circ}\text{C}$, $f=1\text{kHz}$, Load= 4Ω , 230V mains

Symbol	Parameter	Conditions	Min	Typ	Max	Units
V_p	Nominal DC voltage	Off-line input within range	46	47	48	V
V_{cc}	Positive analog supply	Off-line input within range	11.4	12	12.4	V
V_{ss}	Negative analog supply	Off-line input within range	-11.4	-12	-12.4	V
t_{pmax}	Time of maximum rated output power	150W out. No preheating.	-	120	-	s
P_T	Continuous output power ⁴⁾ without thermal shutdown. 0 - 8kHz ⁵⁾	Thermal stab. @ $T_a = 25^{\circ}\text{C}$.	-	40	-	W
P_T	Continuous output power ⁴⁾ without thermal shutdown. 0 - 8kHz ⁵⁾	Thermal stab. @ $T_a = 50^{\circ}\text{C}$.	-	25	-	W
P_{FTC}	FTC rated output power 0 - 8kHz ⁵⁾		-	55	-	W
P_q	Quiescent power consumption	$P_o = 0\text{W}$	-	5	-	W
P_{stby}	Stand-by power consumption	Module in standby at 115V _{AC} 230V _{AC}	- -	0.14 0.25	- -	W
P_{stby}	Stand-by power consumption with Red LED	Module in standby 115V _{AC} 230V _{AC}	- -	0.18 0.28	- -	W
P_{stby}	Stand-by power consumption with Red LED and 6mA supplied by V_{sleep}	Module in standby 115V _{AC} 230V _{AC}	- -	0.26 0.36	- -	W
η	Total power efficiency	$P_o = 200\text{W}$, $R_L = 4\Omega$ $P_o = 100\text{W}$, $R_L = 8\Omega$	-	79 78	-	%

Table 12: Power specifications

4) The module is mounted vertically in free air.

5) The power bandwidth is limited due to the output Zobel network. (See further details on page 11-12)

Audio Specifications

Symbol	Parameter	Conditions	Min	Typ	Max	Units
P _o	Output power @ 0.2%THD+N 10Hz < f < 20kHz (AES17 measurement filter) ⁶⁾	R _L = 4Ω				
		230V _{ac} / 50Hz,	-	200	-	W
		120V _{ac} / 60Hz	-	195	-	
		100V _{ac} / 50Hz	-	190	-	
P _o	Output power @ 0.2%THD+N 10Hz < f < 20kHz (AES17 measurement filter) ⁶⁾	R _L = 8Ω				
		230V _{ac} / 50Hz,	-	100	-	W
		120V _{ac} / 60Hz	-	100	-	
		100V _{ac} / 50Hz	-	100	-	
P _o	Output power @ 1%THD+N 10Hz < f < 20kHz (AES17 measurement filter) ⁶⁾	R _L = 4Ω				
		230V _{ac} / 50Hz,	-	230	-	W
		120V _{ac} / 60Hz	-	220	-	
		100V _{ac} / 50Hz	-	210	-	
P _o	Output power @ 10%THD+N 10Hz < f < 20kHz (AES17 measurement filter) ⁶⁾	R _L = 4Ω				
		230V _{ac} / 50Hz,	-	290	-	W
		120V _{ac} / 60Hz	-	260	-	
		100V _{ac} / 50Hz	-	250	-	
V _{o-max}	Max output voltage	R _L = 4Ω	-	43	-	V _p
I _{o-max}	Max output current	(output current limited)	-	12.5	-	A _p
THD+N	Maximal THD+N in 4Ω (AES17 measurement filter) ⁶⁾	230V _{ac} / 50Hz	-	0.2	0.3	%
		10Hz < f < 20kHz				
		100mW < P _o < 200W				
THD+N	Maximal THD+N in 4Ω (AES17 measurement filter) ⁶⁾	120V _{ac} / 60Hz	-	0.2	0.3	%
		10Hz < f < 20kHz				
		100mW < P _o < 195W				
THD+N	Maximal THD+N in 4Ω (AES17 measurement filter) ⁶⁾	100V _{ac} / 50Hz	-	0.2	0.3	%
		10Hz < f < 20kHz				
		100mW < P _o < 190W				

Table 13: Audio specifications.

6) An Audio Precision AES17 20 kHz 7th order measurement filter is used for measurements. The frequency 6.67kHz corresponds to the worst-case situation where 2nd and 3rd harmonics are within the audio band.

General Audio Specifications

Unless otherwise specified, $f=1\text{kHz}$, $P_O=1\text{W}$, $T_a=25^\circ\text{C}$.

Symbol	Parameter	Conditions	Min	Typ	Max	Units
THD+N	THD+N in 4Ω (AES17 measurement filter) ⁶⁾	$f = 100\text{Hz}$, $P_O=1\text{W}$	-	0.008	0.02	%
$V_{N,O}$	Output referenced idle noise	A-weighted $10\text{Hz} < f < 20\text{kHz}$	75	90	125	μV
A_V	Nominal Voltage Gain	$f = 1\text{ kHz}$	26.3	26.8	27.3	dB
f	Frequency response	20Hz - 20kHz, All loads	-	± 0.5	± 1.0	dB
f_u	Upper bandwidth limit (-3dB)	$R_L = 8\Omega$ $R_L = 4\Omega$	-	65 45	-	kHz
f_l	Lower bandwidth limit (-3dB)	$R_L = \text{All loads}$	-	3.5	-	Hz
Z_o	Absolute output impedance	$f = 1\text{ kHz}$	-	10	20	$\text{m}\Omega$
Z_L	Load impedance range		3	4	∞	Ω
D	Dynamic range	A-weighted at $200\text{W}@4\Omega$	107	110	111	dB
IMD	Intermodulation Distortion (CCIF)	$f = 14\text{kHz}$, 15kHz , $P_O = 10\text{W}$	-	0.0005	-	%
TIM	Transient Intermodulation Distortion (TIM)	$f_1 = 3.15\text{kHz}$ square, $f_2 = 15\text{kHz}$, $P_O = 10\text{W}$	-	0.004	-	%

Table 14: General audio specifications

7) An Audio Precision AES17 20 kHz 7th order measurement filter is used for measurements. The frequency 6.67kHz corresponds to the worst-case situation where 2nd and 3rd harmonics are within the audio band.

Electrical Specifications

Unless otherwise specified, $T_a=25^\circ\text{C}$.

Symbol	Parameter	Conditions	Min	Typ	Max	Units
f_o	Switching frequency	Idle	400	430	460	kHz
f_s	Switching frequency range	Idle to full scale variation	0	-	460	kHz
f_{smps}	Switching frequency power supply		-	65	-	kHz
$V_{OFF,Diff}$	Differential offset on output terminals	Input terminated	-	-	± 30	mV
$V_{OFF,CM}$	Common mode offset on output terminals	Input terminated	-	23.5	-	V
V_{trig}	Signal Sense trigger level			1	3	mV_{RMS}

Table 15: Electrical specifications

Timing Specifications

Symbol	Parameter	Conditions	Min	Typ	Max	Units
t_{acd}	Power supply start up delay.	Time from reaching AC_{min} to all power supplies are good.	-	600	-	ms
t_{sd}	Switching delay at start up	Time from all power supplies are good to startup.	-	3.3	-	s
$t_{standby}$	Shutdown delay	Time to shutdown from signal on Signal Sense disappears	-	13	-	min

Table 16: Timing specifications.

Disturbances on the Mains

The signal on the mains connection is often very noisy and large surge voltages are present. The ICEpower200ASC is equipped with mains filtering to suppress surges and noise.

Lightning

To avoid damage to the ICEpower200ASC in case of surges caused by lightning, special care and component selection have resulted in capability of withstanding surges up to 8kV. (Tested with surge generator meeting IEC1000-4-5 at 8kV).

Mechanical Specifications

During development, the ICEpower200ASC has sustained tough mechanical tests to ensure high reliability

Test	Acceleration	Amount
Unpowered tests: The unit is powered after the test to verify functionality.		
Random vibration	$2g_{RMS}$	3x20min
Bump	10g/16ms, 2-4 Hz	1000 bumps in each of 6 directions ⁸⁾
Shock	70g/12ms	3 shocks in each of 6 directions ⁸⁾
Powered tests: The unit is tested with power applied.		
Sinusoidal vibrations	2.5mm, 5-10Hz 1g, 10-100Hz	2 hours in each of 3 directions ⁸⁾
Random vibrations	0.01g, 10-20Hz 0.7g _{RMS} -3dB/oct, 20-150Hz	2 hours in each of 3 directions ⁸⁾

Table 17: Mechanical tests

8) 6 directions: (up, down, left, right forward and backward). 3 directions: (up and down, left and right, forward and backward)

Typical Performance Characteristics

Standby performance

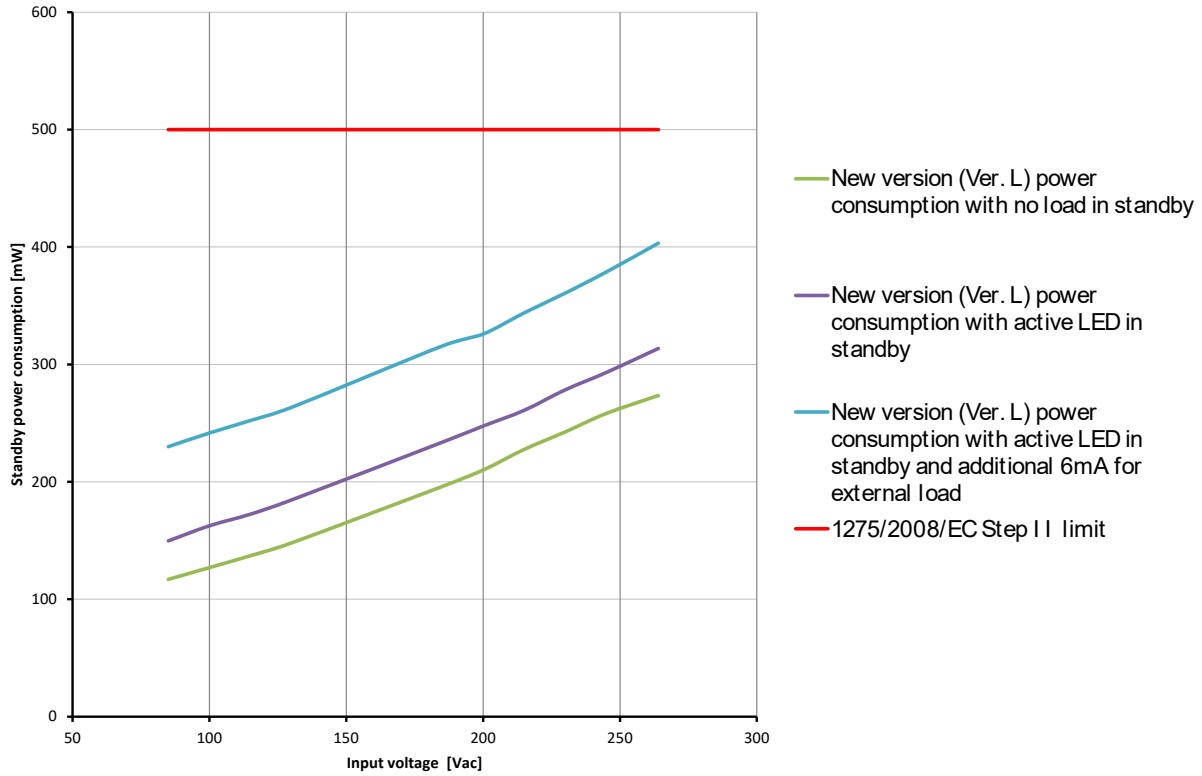

Frequency Response

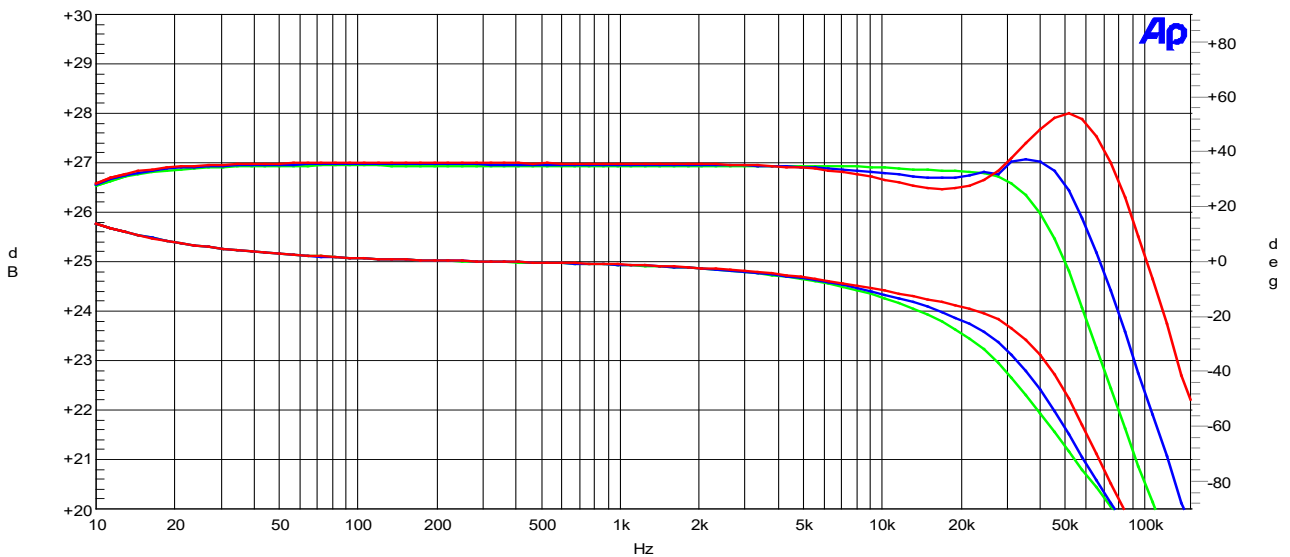
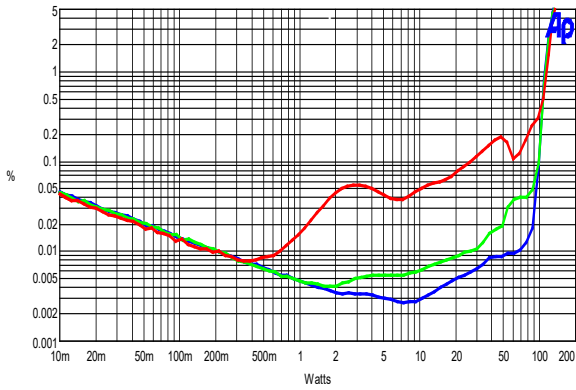
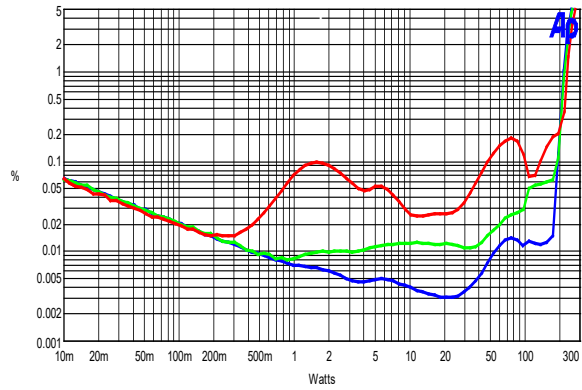

Figure 2: Frequency response in 4Ω (green), 8Ω (blue) and open load (red). Top – amplitude. Bottom – phase.

Harmonic Distortion & Noise



THD+N vs. Po at 100Hz, 1kHz and 6.67kHz⁸⁾ (8Ω), 230Vac/50Hz



THD+N vs. Po at 100Hz, 1kHz and 6.67kHz⁸⁾ (4Ω), 230Vac/50Hz

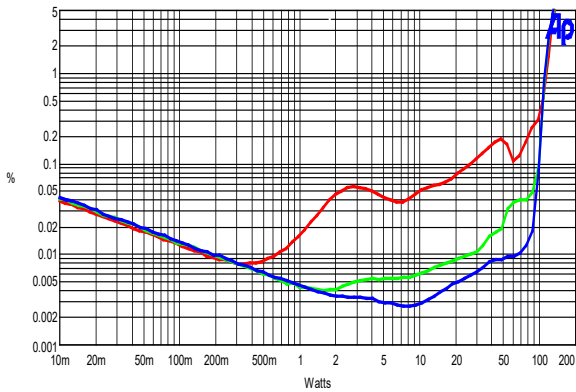

THD+N vs. Po at 100Hz, 1kHz and 6.67kHz⁹⁾ (8Ω), 110Vac/50Hz

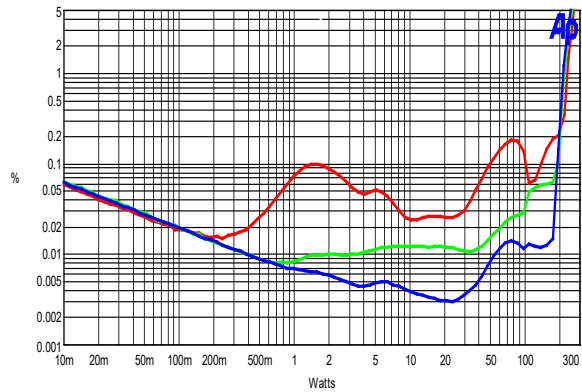

THD+N vs. Po at 100Hz, 1kHz and 6.67kHz⁹⁾ (4Ω), 110Vac/60Hz

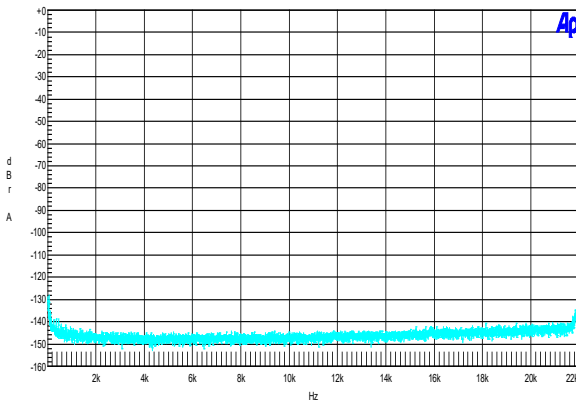

Idle noise (16K FFT). Residual = 90μV(A).

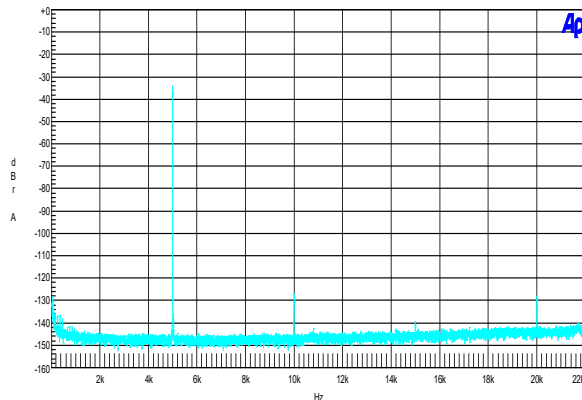

f = 5kHz. Po = 100mW. 4Ω loading.

Figure 3: Total harmonic distortion & noise.

9) An Audio Precision AES17 20 kHz 7th order measurement filter is used for measurements. The frequency 6.67kHz corresponds to the worst-case situation where 2nd and 3rd harmonics are within the audio band.

Intermodulation Distortion (CCIF & TIM)

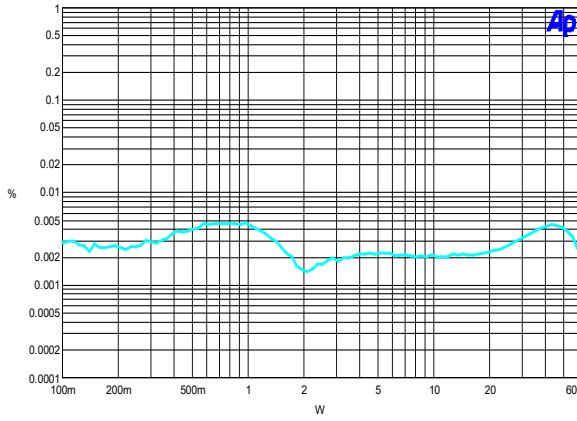

CCIF IMD vs. P_o, R_L = 4Ω, f₁ = 14kHz, f₂ = 15kHz.

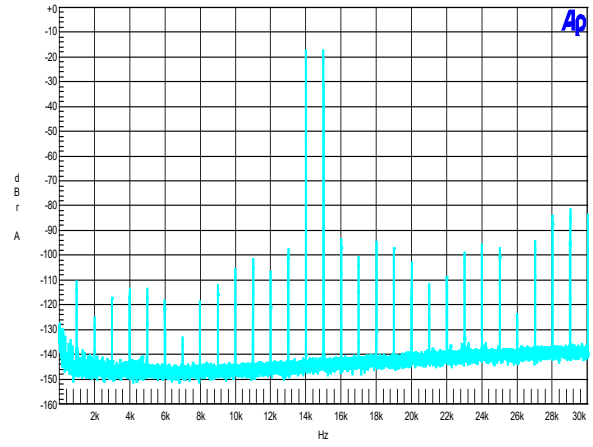

CCIF IMD analysis. R_L = 4Ω, P_o = 10W, IMD = 0.0005%.

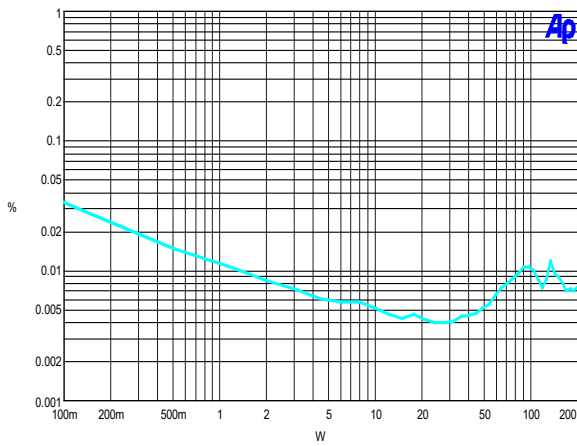

TIM vs. output power. R_L = 4Ω.

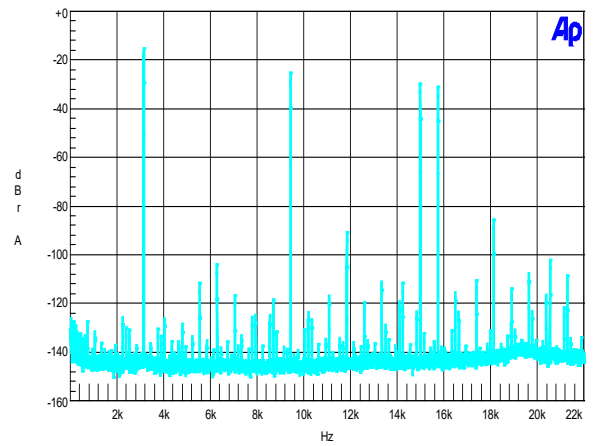

TIM FFT analysis. R_L = 4Ω, P_o = 10W, TIM = 0.004%.

Figure 4: Intermodulation distortion

Power vs. Frequency

Due to the compensating Zobel network in the output stage, the maximum allowable short-term output power is frequency-dependant. The short-term output power is defined as the maximum undistorted (THD+N < 0.2%) output power until thermal shutdown occurs.

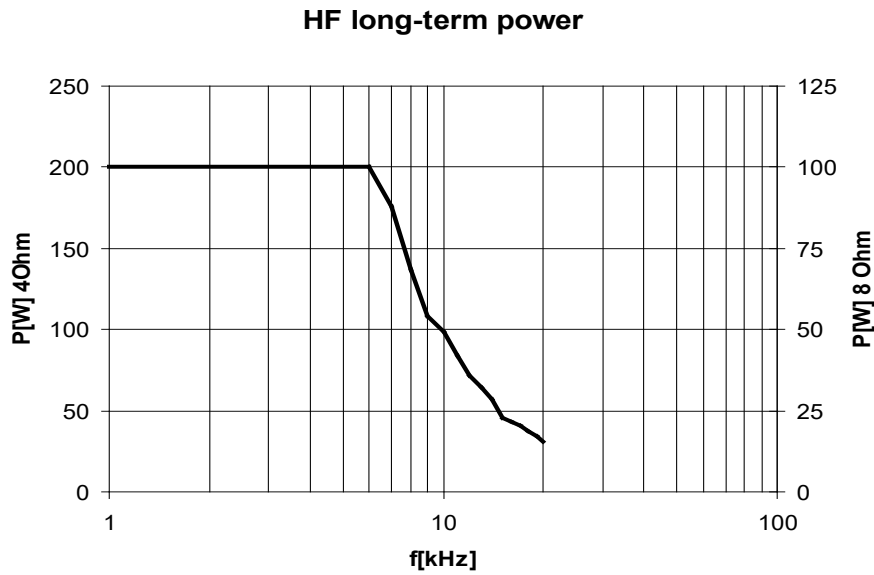

Figure 5: HF long-term output power

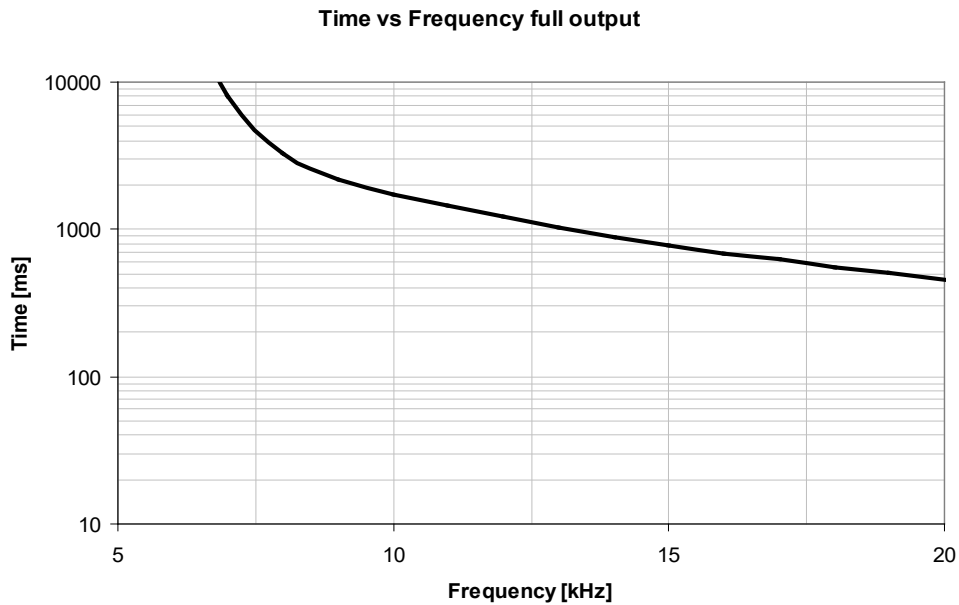

Figure 6: Time at full output vs. frequency

Note that this limitation will never cause problems when the amplifier is fed a music signal at the input, but the limit must be taken into consideration when the amplifier is tested under laboratory conditions using sine waves or noise signals.

The figure below shows the relationship between output power and duration for three different frequencies (10kHz, 15kHz & 20kHz). The figure shows the absolute maximum rating before the Zobel-circuit will be permanently damaged.

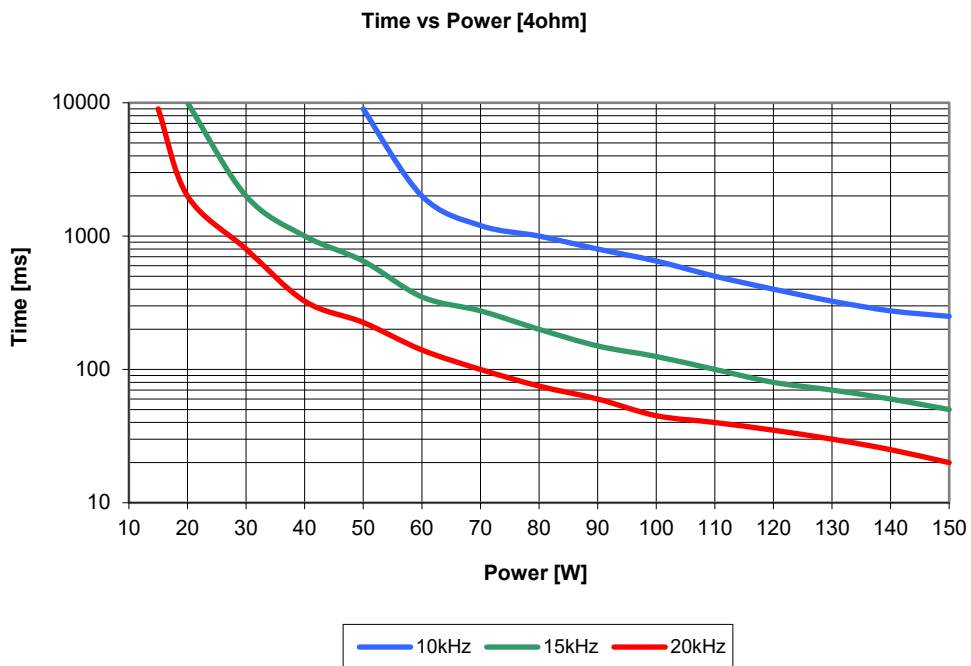

Figure 7: Power vs. Time [4Ω] 10kHz, 15kHz, 20kHz

Output Impedance

The output impedance is measured by feeding 1A_{RMS} into the output of the amplifier measuring the voltage on the output. The voltage then corresponds to the output impedance. The output impedance is measured directly on the terminals on the PCB.

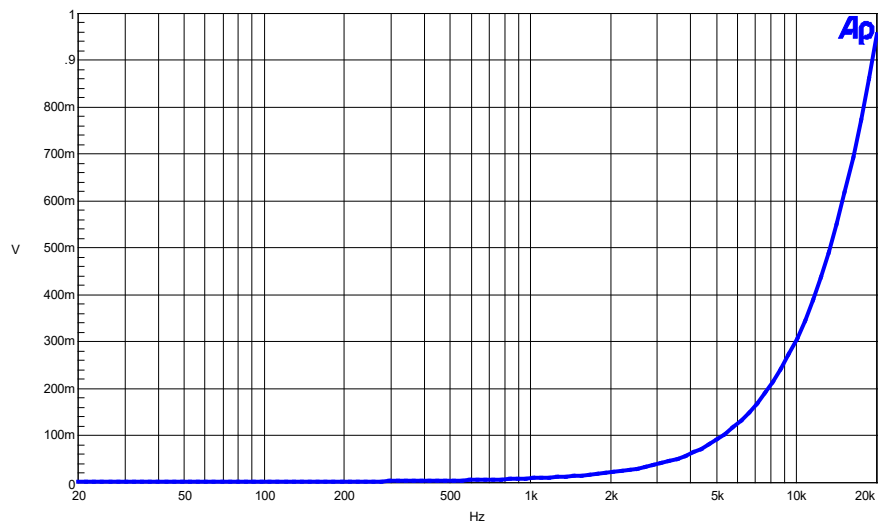

Figure 8: Measured voltage at output terminals while feeding 1ARMS into the output of the amplifier at PCB.

The figure below shows a zoom of the output impedance from 20Hz – 5kHz.

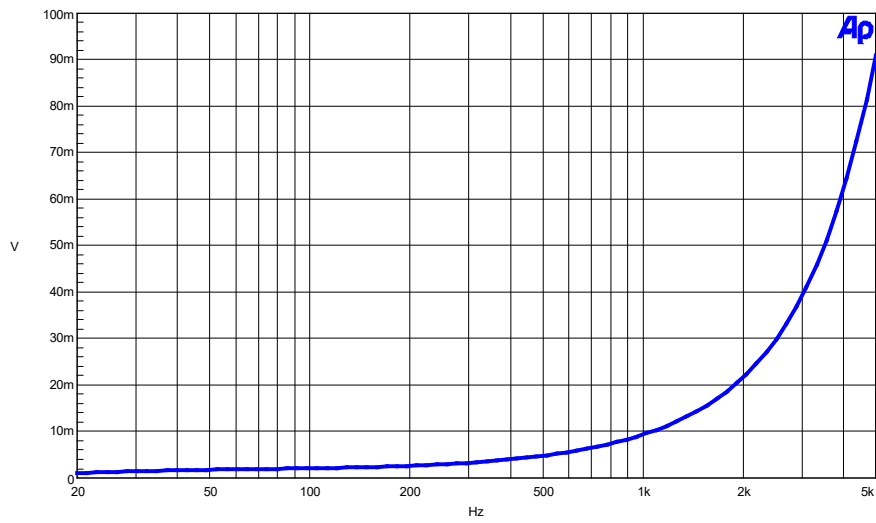

Figure 9: Measured voltage at output terminals while feeding 1A_{RMS} into the output of the amplifier at PCB.

Damping Factor

The damping factor is calculated as the ration between the output impedance of the amplifier and the load impedance.

Damping Factor

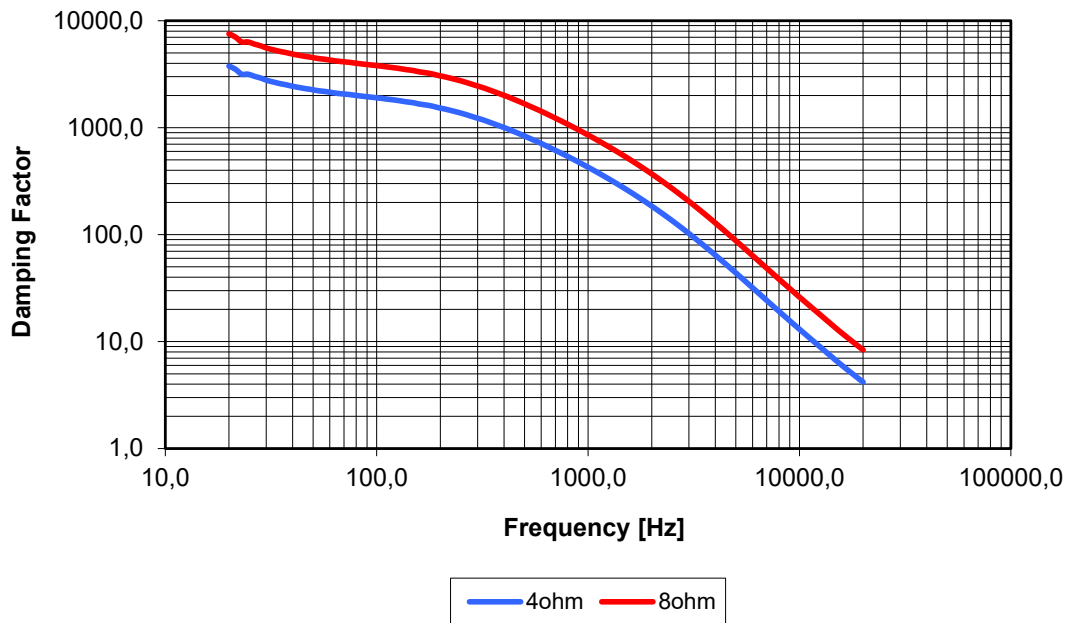

Figure 10: Damping factor vs. frequency 4Ω

Loading

With its low output impedance, the ICEpower200ASC is designed to be unaffected by loudspeaker loading characteristics. However, care should be taken with *purely* capacitive loads.

Traditionally amplifiers have been tested extensively in laboratories with purely capacitive loads. This was done to test the amplifier's stability and performance but it does not relate to any normal speaker load as even electrostatic speakers do not present a purely capacitive load to the amplifier but include a resistive part as well. The maximum purely capacitive load allowed is 330nF.

Dissipated Power vs. Output Power

The table below shows the dissipated power under three different load conditions and three different mains voltages.

	Load impedance [Ω]	Rated power [W]	Line power [W]	Output power [W]	Dissipated power [W]
Mains voltage V_{in}			100V/50Hz		
Idle ($P_o = 0$ [W])			4		4
1/8 rated power (pink noise)	4	200	37	28	9
	8	100	20	14	6
FTC rated power (pink noise)	4	55	74	57	17
	8	55	73	58	15
Mains voltage V_{in}			120V/60Hz		
Idle ($P_o = 0$ [W])			4.3		4.3
1/8 rated power (pink noise)	4	200	38	28	10
	8	100	21	14	7
FTC rated power (pink noise)	4	55	74	58	16
	8	55	72	58	14
Mains voltage V_{in}			230V/50Hz		
Idle ($P_o = 0$ [W])			4.6		4.6
1/8 rated power (pink noise)	4	200	40	28	12
	8	100	23	14	9
FTC rated power (pink noise)	4	55	74	56	18
	8	55	72	56	16

Table 18: Dissipated power vs. Output power

Input						Output		
Required		Measured				Vrms	W	Ohms
V	Hz	V	Hz	A	W			
100	60	100	60	4.307	302	26.9	180.0	4.02
240	50	240	50	2.140	279	27.1	182.7	4.02
1 kHz sine wave input and 4 ohm output load								

Table 19: Mains power draw vs. Output power with *AUX

Input						Output		
Required		Measured				Vrms	W	Ohms
V	Hz	V	Hz	A	W			
90	60	90	60	1.435	78.6	9.7	23.4	4.02
120	60	120	60	1.158	77.4	9.8	23.9	4.02
200	50	200	50	0.799	77.3	9.7	23.4	4.02
220	50	220	50	0.737	76.5	9.6	22.9	4.02
240	50	240	50	0.700	77.4	9.7	23.4	4.02
264	50	264	50	0.653	77.3	9.7	23.4	4.02
1 kHz sine wave input, 1/8 output power and 4 ohm output load								

Table 20: Mains power draw vs. Output power with *AUX

*AUX Load during test +12Vdc: 0.200 A, -12Vdc: 0.200 A, Vp(47V): 0.660 A.

Speaker load includes cables, output power is calculated based on this value, $V^2/R = W$

Features

The ICEpower200ASC has a number of useful features as described below

Standby/On LED indication

Figure 11 shows how to connect the external LEDs for indicating On/Standby modes. The figure also shows the internal circuit that drives the two LED's. If LED indication is not required, any of the two LED's can be left out without affecting operation of the board. Red light indicates Standby mode and green light indicates On mode.

The red LED will turn on if any of the amplifier protection features are activated. The red light will also illuminate during the power up sequence, and not switch off until the amplifier is enabled and ready to play. The green LED will remain turned on during protection indication.

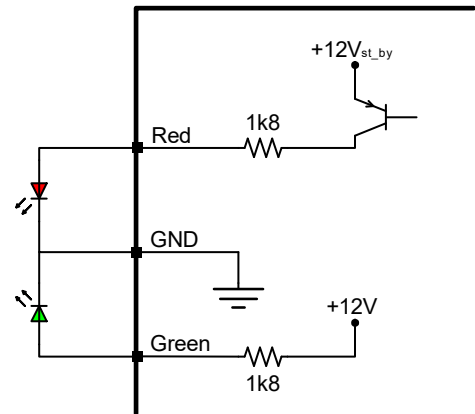

Figure 11: LED indication for St-By/On

Signal Sense

The board is able to power up from standby mode by applying an audio signal to the Signal_Sense input pin.

When an audio signal is detected the power supply will switch from standby mode to on mode and the amplifier will turn on. The power supply will return to standby mode again if no audio signal has been detected for 13 minutes. If the this feature is not required the input it can be left unconnected or connected to ground.

The internal circuit for the Signal_Sense input pin is shown in figure 12.

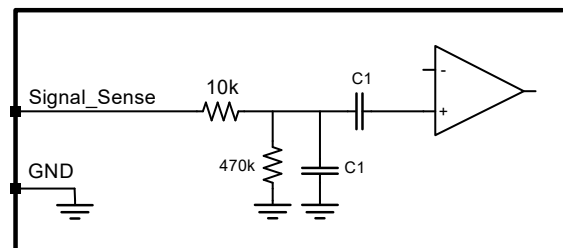

Figure 12: Signal_Sense input

Vsleep

This low power DC output can be used for supplying external wake-up circuits such as microprocessors. The output can supply up to 6mA. The output impedance is quite high as shown in figure 14. This means that the output voltage drops as a function of the loading on this pin.

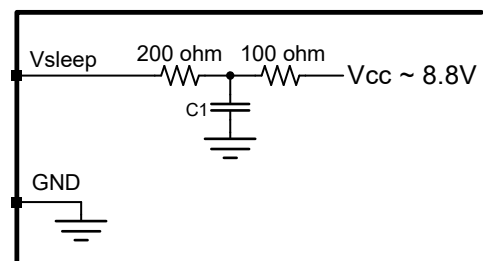

Figure 13: Vsleep output

Auto On/Off Application

The Auto on/off input pin can be used in several ways to control the on/off behavior of the ICEpower200ASC.

- On/Off by Signal sense: If the ICEpower200ASC should power up when an input signal is detected, the Auto-on/off pin should be unconnected and the Signal Sense pin connected to the input signal. The board will then turn on when an input signal is detected and automatically shut down app. 13 minutes after the input signal has been removed.
- On/Off by mains switch: If the board should power up when mains voltage is present, the Auto_On/Off pin should be connected to GND as shown in figure 15 to disable the Signal Sense feature.
- On/Off by control signal: The Auto on/off input pin can also be used to control the standby/on mode via an external control signal. The recommended external circuit for this is illustrated in figure 16. The board will turn on when the external transistor turns on.

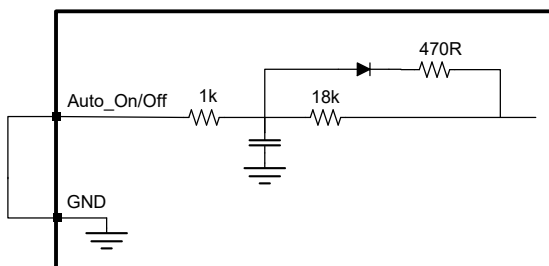

Figure 14: Normal On/Off application

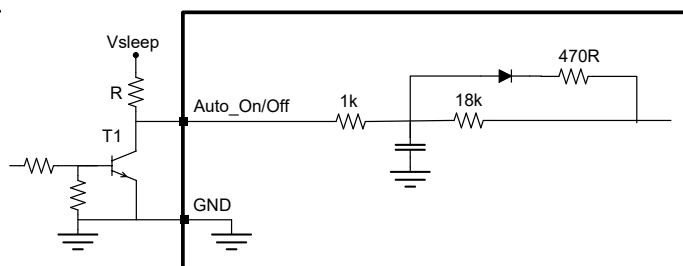

Figure 15: Controlled On/Off application

Please refer to the ICEpower200ASC Designer's Manual for additional information.

Protection Features

The ICEpower200ASC is equipped with several protection features for surviving overload without damage.

The schematic below illustrates the different protection features.

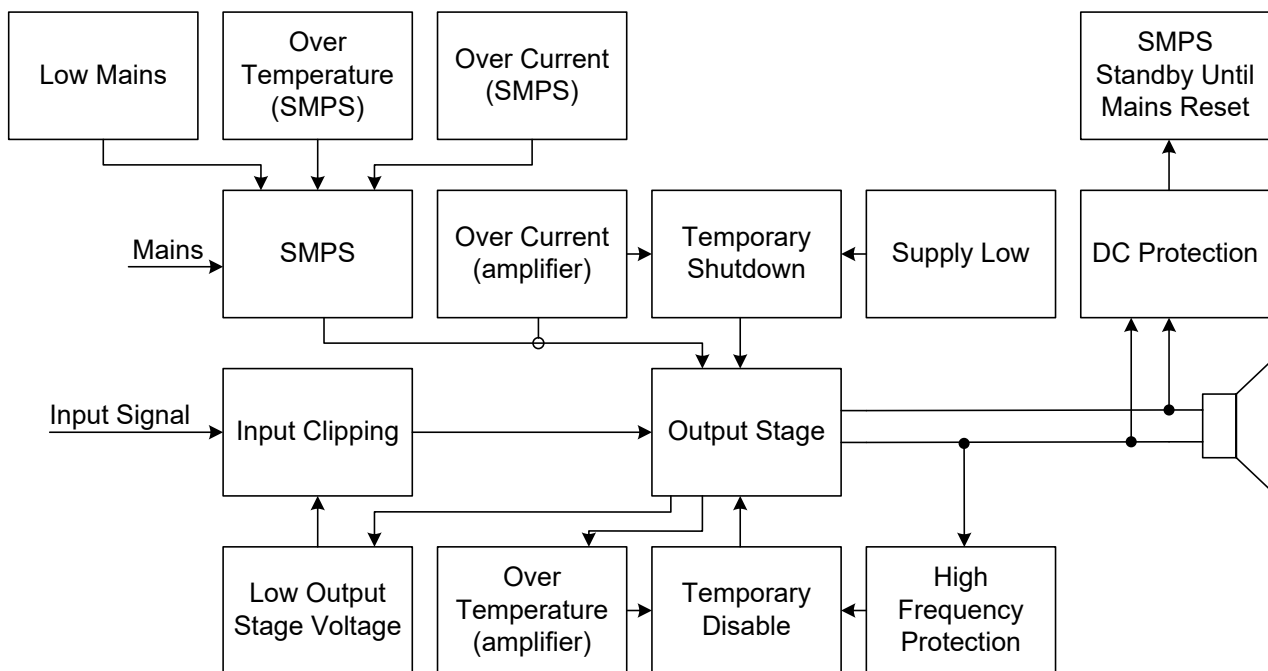

Figure 16: Block diagram of protection features.

Overcurrent protection (amplifier)

This feature protects the amplifier in case the output current exceeds 12.5A. When the current reaches 12.5A the amplifier will be briefly disabled then automatically restart. Upon restarting, if the current still is too high the amplifier is disabled again. This means that the amplifier will perform automatic current clipping. The red LED will illuminate when clipping is active and the green Power LED will continue to be on. Note that shorting one of the output terminals to GND, either on the module itself or on an external part such as a shielding box, will cause irreparable damage to the module.

Thermal protection (power supply & amplifier)

The ICEpower200ASC is equipped with two thermal protection circuits. The first circuit monitors the temperature of the power supply and disables it if the temperature becomes too high. The other protection circuit monitors the amplifier temperature and disables/shuts down the amplifier if the temperature of the output stage becomes too high.

In case of thermal shutdown in the amplifier section the red LED will turn on and the green LED will remain turned on. If the thermal shutdown is caused by the power supply the board shuts completely down and all LED indication is turned off. In both instances the ICEpower200ASC will be momentarily disabled and then start again. Thermal shut down is only expected to occur in case of abuse or under fault conditions.

High-frequency protection (amplifier)

The output filter of the amplifier is not capable of handling large long-term high frequency signals due to the output Zobel-network and the high-frequency protection circuit disables the amplifier in case of overload to protect the Zobel-network. If overload occurs, the red LED will turn on while the green LED will remain turned on. The amplifier will be momentarily disabled and then start again.

Input/Output Interfaces

Input Stage

The balanced input section provides signal buffering and anti-aliasing filtering. The balanced configuration helps to avoid hum and noise pick-up from poorly shielded cables. An unbalanced input can be obtained by applying a short between Vi- and AGND. This does not affect the overall gain.

The input impedance of the input section is approximately $10k\Omega$ over the audio bandwidth, which is an acceptable loading condition for pre-amps, active crossover outputs etc.

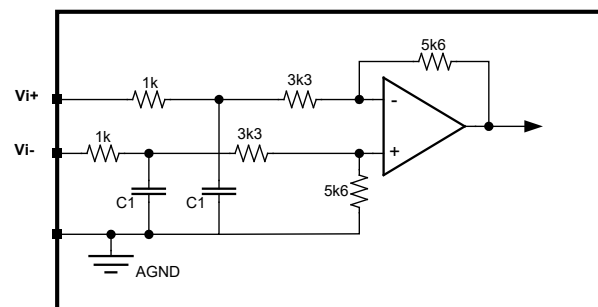

Figure 17: Balanced input buffer.

Output Stage

The output stage is a full bridge topology with a 2nd order filter, thus the power output on the terminals Vo+ and Vo- is balanced. The filter design is a part of the proprietary MECC topology and has been chosen as a compromise between demodulation characteristics, efficiency and filter compactness.

The essential output characteristics are:

- The switching residual on the output primarily consists of a single frequency component at the carrier fundamental f_s .
- The system bandwidth is 65kHz in 8Ω .

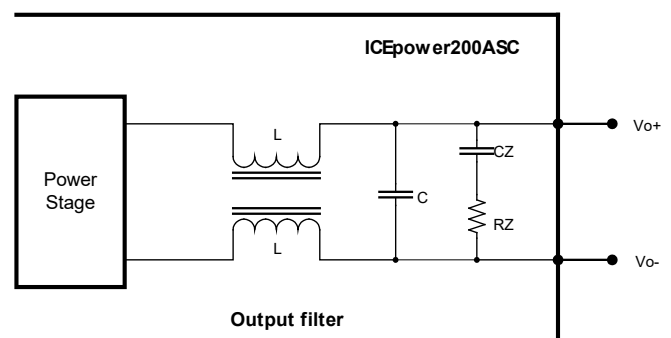

Figure 18: Output filter section with compensating Zobel network.

Warning! The balanced speaker outputs are both “hot” with a common-mode DC level equal to $V_p/2$. Shorting one of the terminals to ground will cause irreparable damage to the module. Balanced probes should always be used for monitoring and measurements.

Operational Timing Diagram

The following diagrams show selected signals during power up/power down.

Timing when Auto_On/Off is connected to ground

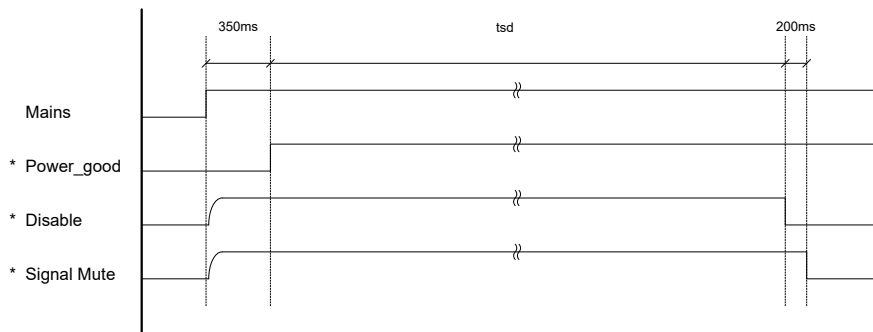

Figure 19: Power up from mains on. * denotes an internal signal.

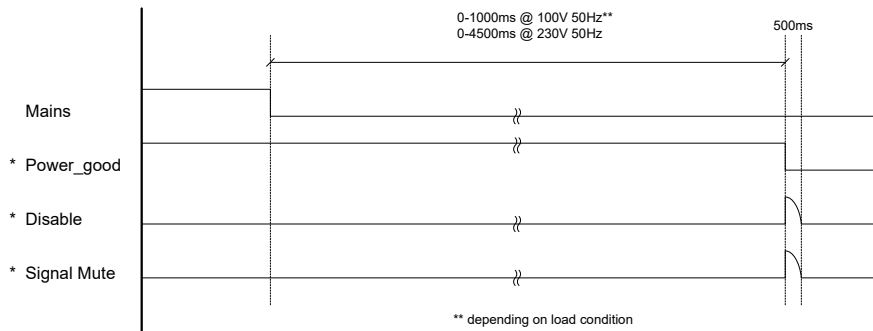

Figure 20: Power down after mains off. * denotes an internal signal.

Timing with Signal Sense

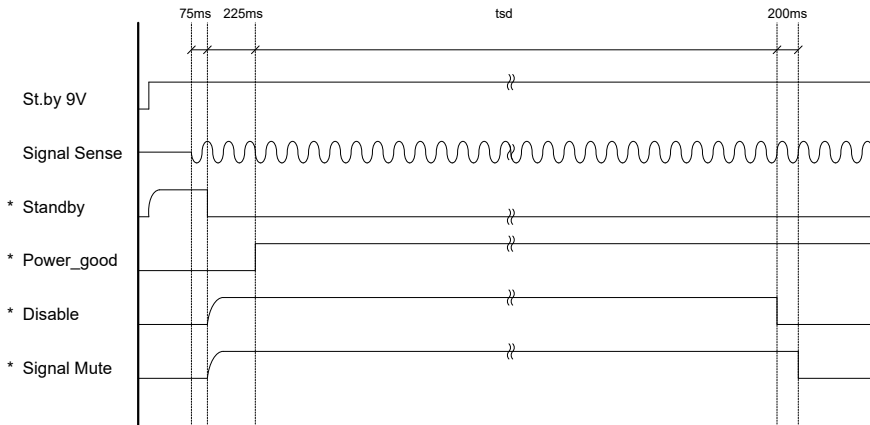

Figure 21: Power up on Signal Sense. * denotes an internal signal.

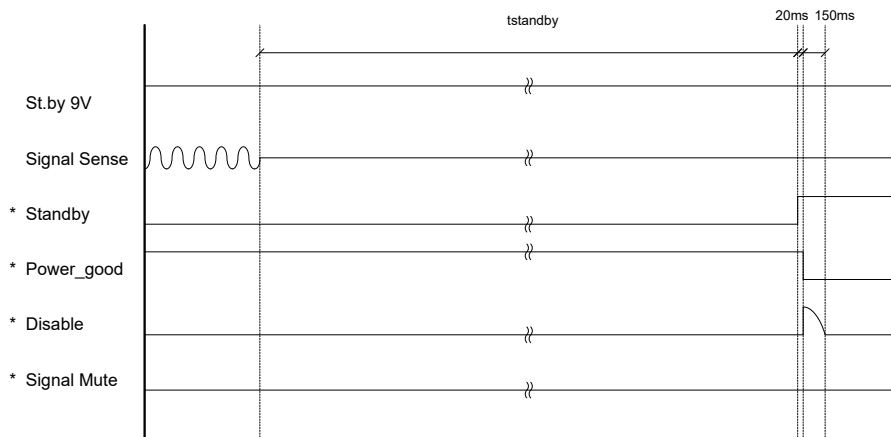

Figure 22: Power down controlled by Signal Sense. * denotes an internal signal.

Thermal Design

Thermal design is generally a great challenge in power amplifier systems. Linear amplifier designs operating in class A or AB are normally very inefficient and therefore equipped with extensive heat sinking to keep the transistor junction temperature low. The ICEpower200ASC is based on highly efficient ICEpower switching technology providing high overall efficiency characteristics at all levels of operation.

Part of the “component” philosophy of the ASC-series is to provide a self-cooled component thus eliminating the need for special attention to thermal design.

The ICEpower200ASC module is designed for music reproduction, which means that the output power of the amplifier will never be continuous. If the average power exceeds 40W @ 4Ω (typical) for a long time at 25°C ambient temperature, the module will reach its maximum allowable temperature and the temperature protection will be activated. At 50°C ambient temperature more than 25W @ 4Ω (typical) average power will activate the temperature protection.

Further information is located in the ICEpower ASC Designer's Manual.

Physical Dimensions

All dimensions are in mm.

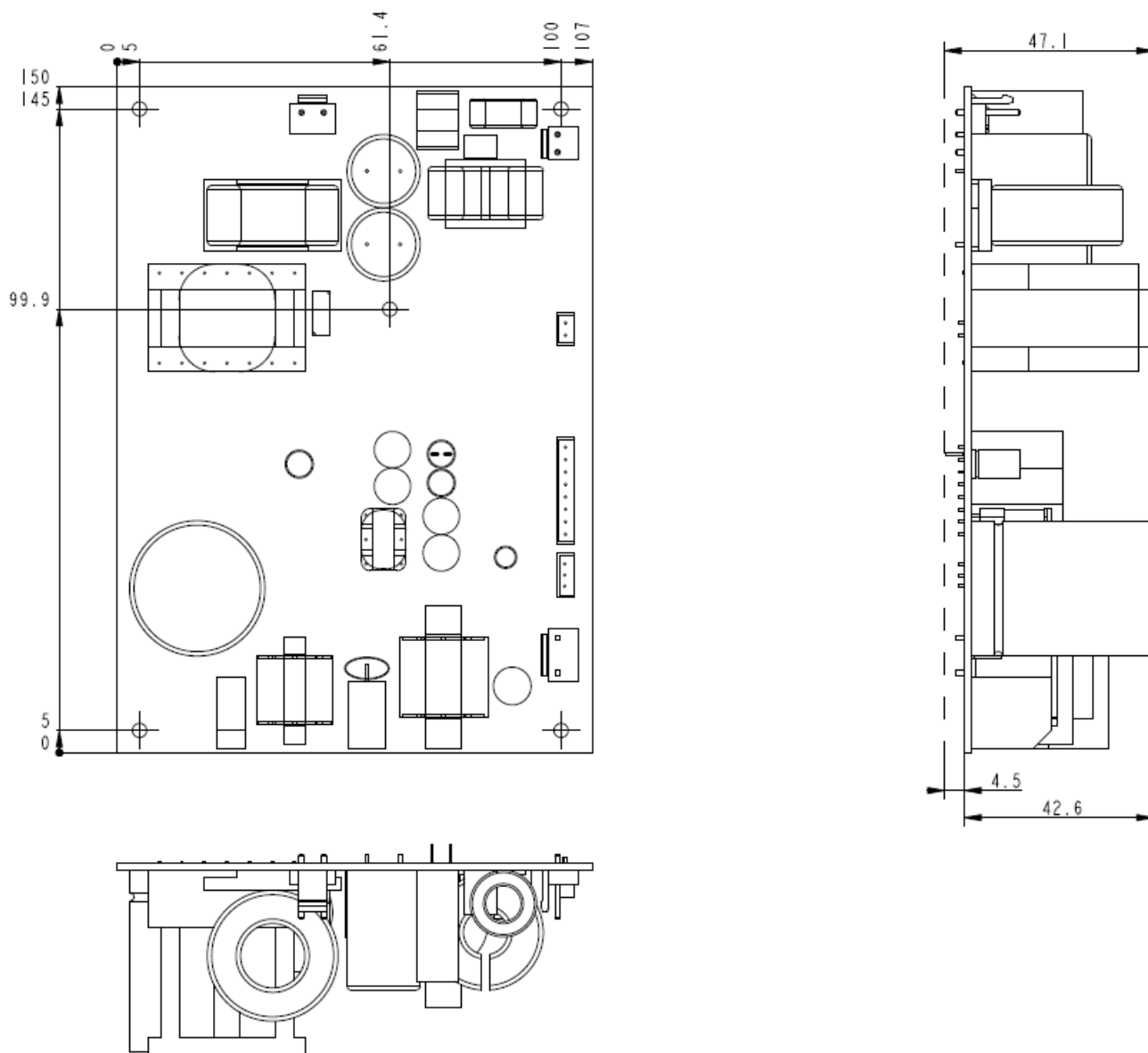

Figure 23: Physical dimensions in mm.

Note: A minimum clearance of 12 mm. around the module is required for safety and ventilation reasons.

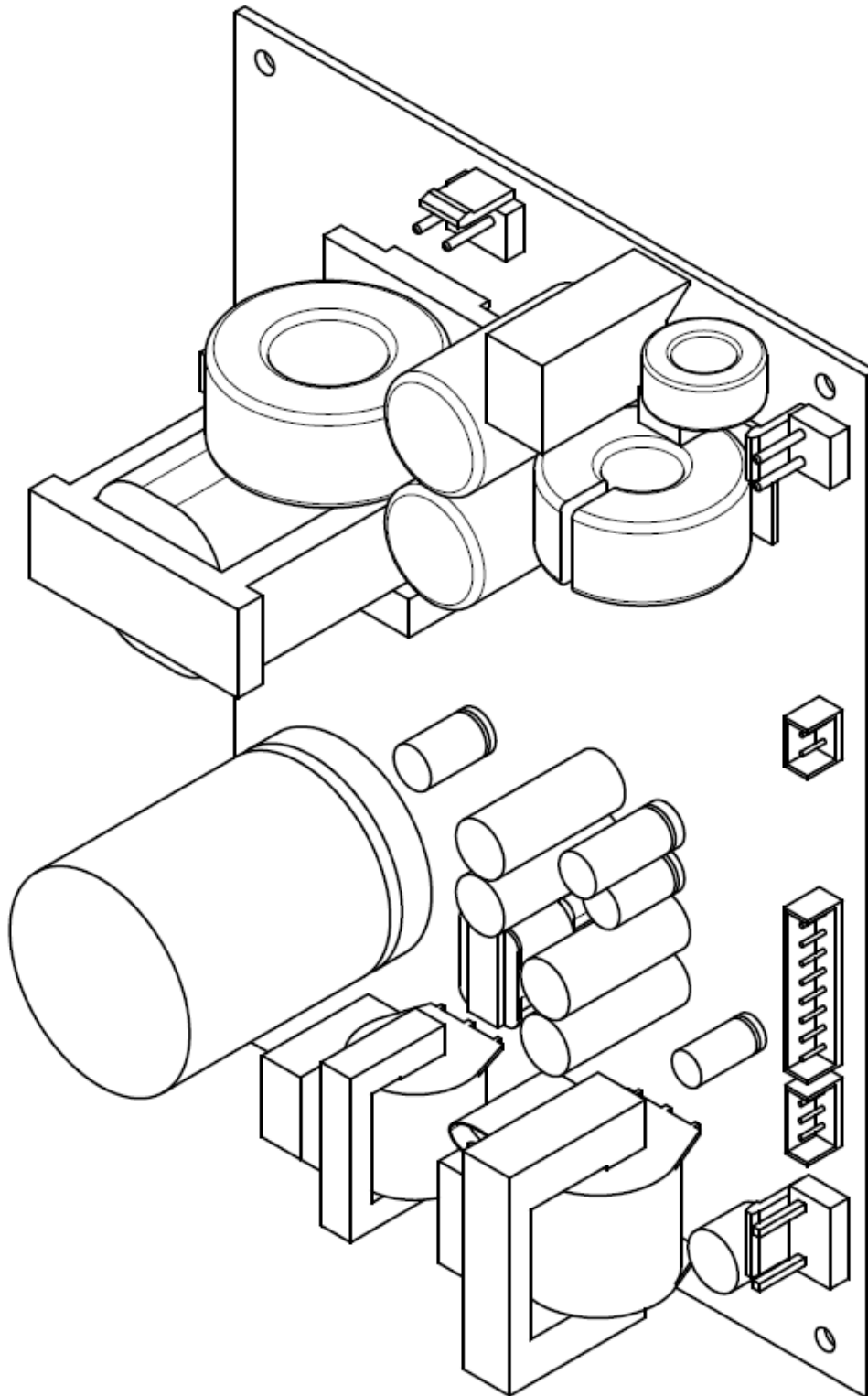

Figure 24: 3D view of the board.

Safety Standards

The ICEpower200ASC has been pre-approved for safety by CSA to ease the design-in procedure and complies with the following standards:

Europe:

IEC 62368-1:2014 (Second Edition)
IEC 62368-1:2014 / A11: 2017
IEC 60065 7th ed. + AM1 + AM2
IEC 60065 8th ed
EN 60065:2002 + A1:2006 + A11:2008 + A2:2010 + A12:2011
EN 60065:2014

US:

UL 62368-1 and CAN/CSA C22.2 No. 62368-1-14
UL 60065, 7th Edition, 2013-07-24
CAN/CSA-C22.2 No. 60065-03, 1st Edition + A1:2006 + A2:2012

Safety class

Class 2 (without earth)

EMI Standards

EMI Conforms to:

EN55013
EN55020
EN61000-3-2
EN61000-3-3
CISPR 13
CISPR 20
IEC 61000-3-2
IEC 61000-3-3
FCC part 15-B
EN 55032: Note 1

Note1: Depends on cable routing on the mains/amplifier outputs and load characteristics. Connecting safety ground to the mains side/ Additional filtering may be needed.

ESD Warning

ICEpower products are manufactured according to the following ESD precautions:

- IEC 61340-5-1: Protection of electronic devices from electrostatic phenomena. General Requirements.
- IEC 61340-5-2: Protection of electronic devices from electrostatic phenomena. User Guide.

- ANSI/ESD-S20.20-1999: Protection of Electrical and Electronic Parts, Assemblies and Equipment.

Further handling of the products should comply with the same standards.

The general warranty policy of ICEpower a/s does not cover ESD damaged products due to improper handling.

Packaging and Storing

Package	Dimensions (w x d x h)	Gross Weight
Carton	76 x 41 x 18 cm.	13.5 kgs.
Pallet	90 x 90 x 135 cm	175 kgs.

ESD safe cardboard is used for wrapping.

Storage humidity

Do not expose the pallets to rain or humidity levels higher than 85%.

Storage temperature

The pallets are to be stored at temperatures from 0°C to 70°C.

Stacking

Pallets may not be stacked on top of each other.

Contact

For additional information about the ICEpower® technology from ICEpower a/s, visit our web site or contact us.

ICEpower a/s
Vandtårnsvej 62A. 3rd floor B
DK-2860 Søborg
Denmark

www.icepower.dk
info@icepower.dk

Legal Notes

ICEpower a/s believes that the information in this datasheet is accurate and reliable. However it is provided "as is" without any warranties of any kind. ICEpower a/s and its suppliers, to the fullest extent permitted by law, disclaim all warranties, including the warranty of merchantability, warranty of non-infringement of third-party rights, and the warranty of fitness for a particular purpose. ICEpower a/s and its suppliers make no warranties about the accuracy, reliability, completeness, or timeliness of the material, services, software, text, graphics and links. In no event will ICEpower a/s be liable to any party for any damages whether direct, indirect, special, consequential or other for any use or inability to use of this datasheet, including, without limitation, any damages for lost profits, business interruption, loss of programs or other data on your information handling system or otherwise, even if we are expressly advised of the possibility of such damages.

Information in this datasheet may contain technical inaccuracies or typographical errors. The information in the datasheet may be changed at any time without prior notice or obligation.

ICEpower® is a trademark of ICEpower a/s.

ICEpower a/s products are not authorized for use as critical components in life support devices or life support systems without the express written approval of the president and general counsel of ICEpower a/s. As used herein:

- Life support devices or systems are devices or systems which, (a) are intended for surgical implant into the body, or (b) support or sustain life, and whose failure to perform when properly used in accordance with instructions for use provided in the labelling, can be reasonably expected to result in a significant injury to the user.
- A critical component is any component of a life support device or system whose failure to perform can be reasonably expected to cause the failure of the life support device or system, or to affect its safety or effectiveness.

ICEpower a/s ©2016