

ICEpower a/s, Vandtårnsvej 62A 3B, DK-2860 Søborg  
Phone +45 31 71 00 01, CVR-no. 25053591  
info@icepower.dk, [www.icepower.dk](http://www.icepower.dk)

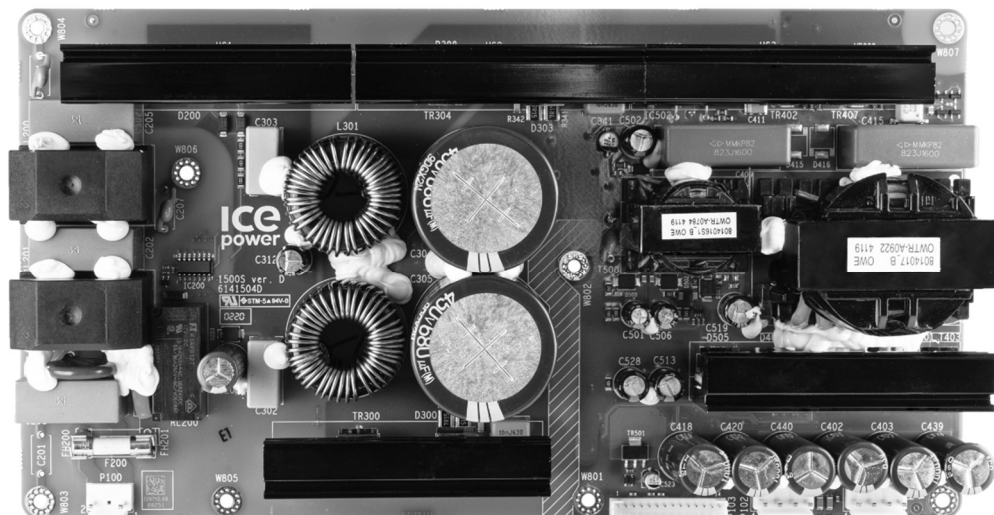

## ICEpower 1500S

Universal mains power supply for professional audio. Features unity power factor correction for optimal usage of available AC power and an AUX converter.

# 1 Contents

1	Contents .....	2
2	General Description .....	4
2.1	Features .....	4
2.2	Key Specifications .....	4
3	Document History .....	4
4	Getting Started .....	5
4.1	Identification of model .....	5
5	Block Diagram .....	5
6	Connectors .....	6
6.1	P100: AC Mains Connector .....	7
6.2	P101/P102: Hanger Rail Supply Connector .....	7
6.3	P103: Control Connector .....	7
7	Absolute Maximum Rating .....	8
8	Electrical Specifications .....	8
8.1	Power .....	9
8.2	Control and Status .....	10
8.3	Timing .....	10
8.4	Power Supply – Main Output – 47V variant .....	11
8.5	Power Supply – Main Output – 57V variant .....	11
8.6	Power Supply – Main Output – 69V variant .....	12
8.7	Power Supply – Auxiliary Outputs .....	13
8.8	Power Supply – Common .....	14
9	Mechanical Specification .....	15
9.1	Dimensions .....	15
9.2	Mounting Holes .....	16
9.3	Environmental Specifications .....	16
9.4	Mechanical and Environmental Tests .....	17
10	Typical Performance Characteristics .....	18
10.1	Power versus mains voltage – 1500S .....	18
10.2	Power Efficiency - 1500S .....	18
10.3	Dissipated Power - 1500S .....	19
11	Functional Description .....	20
11.1	AC Mains Input .....	20
11.2	Control and Status .....	21
11.3	Hanger Rail Supply .....	26
12	Interface Schematics .....	26
12.1	Analog Output .....	26
12.2	Control Input .....	27
12.3	Status Output .....	27

12.4	PSU_OK.....	27
13	Integration Guidelines .....	28
13.1	Grounding Scheme.....	28
13.2	EMC Management .....	29
13.3	Thermal Design .....	31
13.4	Safety Certification Notes.....	31
14	Safety and EMC Standards .....	32
14.1	Safety .....	32
14.2	EMC .....	32
15	ESD Warning .....	33
16	Ordering, Packaging and Storage .....	33
16.1	Ordering Information.....	33
16.2	Shipping Dimensions and Weight .....	33
16.3	Storage Conditions.....	33
17	Contact.....	34
18	Legal Notes .....	34

## 2 General Description

ICEpower 1500S is a universal mains power supply for professional audio. It features unity power factor correction for optimal usage of available AC power and an auxiliary power supply.

The ICEpower 1500S provides comprehensive protection and monitoring functions nevertheless with an easy-to-use control interface.

ICEpower 1500S safety pre-approved and verified to comply with EMC standards enabling fast design-in and minimum time to market.

### 2.1 Features

Voltage variants for 100W@8Ω, 150@8Ω and 200W@8Ω available	1500S can supply up to 8 400A2 or 300A2 amplifier modules enabling up to 16 channels
Comprehensive protection and monitoring functions	Keeps track of module operation and protects the module from overload
Powerful 60 W auxiliary power supply	Supply for analog and control circuits in e.g. a signal front-end
Auxiliary power supply with overload protection	Ensures reliable and robust end-products
EMC evaluated and safety pre-approved	Suitable for CE and FCC approved designs and enabling fast design-in and minimum time to market
Universal mains with active Power Factor Correction	No need for region specific variants and designed for optimal usage of available AC power

### 2.2 Key Specifications

- Universal Mains
- 1500 Watt Output power, 2400 Watt peak.
- Power Factor Corrected
- 60W auxiliary Converter

## 3 Document History

Version	Date	Revised by	Changes
2.0.10	2021-02-12	KLK/LBH	Released version
2.0.11	2021-03-17	CS/LBH	Updated Vdrive max output current

# 4 Getting Started

The ICEpower 1500S will start up into disabled mode with only DVDD, AVDD, AVSS and Vdrive active once mains power is connected. To power up main converter an external enable signal is required, on P103, pin 10 PSU\_Enable.

## 4.1 Identification of model

The different models can be identified in two ways. On PCB rev. D and older the model is found in the serial number of the product on the 2D barcode.

- xx074xxxxxxxx -> 1500S-47V
- xx130xxxxxxxx -> 1500S-57V
- xx126xxxxxxxx -> 1500S-69V

From PCB rev. E and forward the model is identified from the silkscreen. A resistor is mounted on the location R47, R57 or R69 to identify the actual model.

1500S-47V	R47
1500S-57V	R57
1500S-69V	R69

# 5 Block Diagram

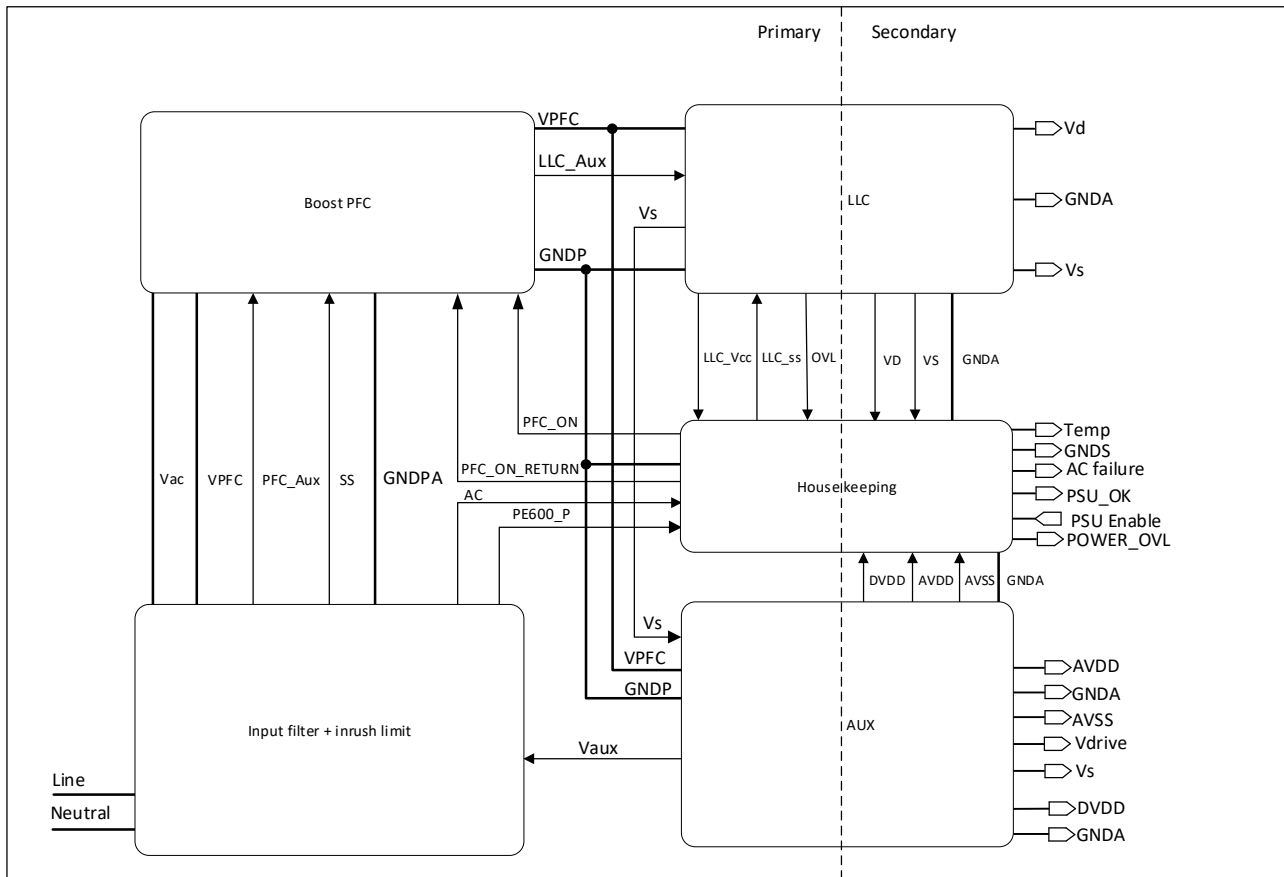

Figure 1: ICEpower 1500S block drawing

## 6 Connectors

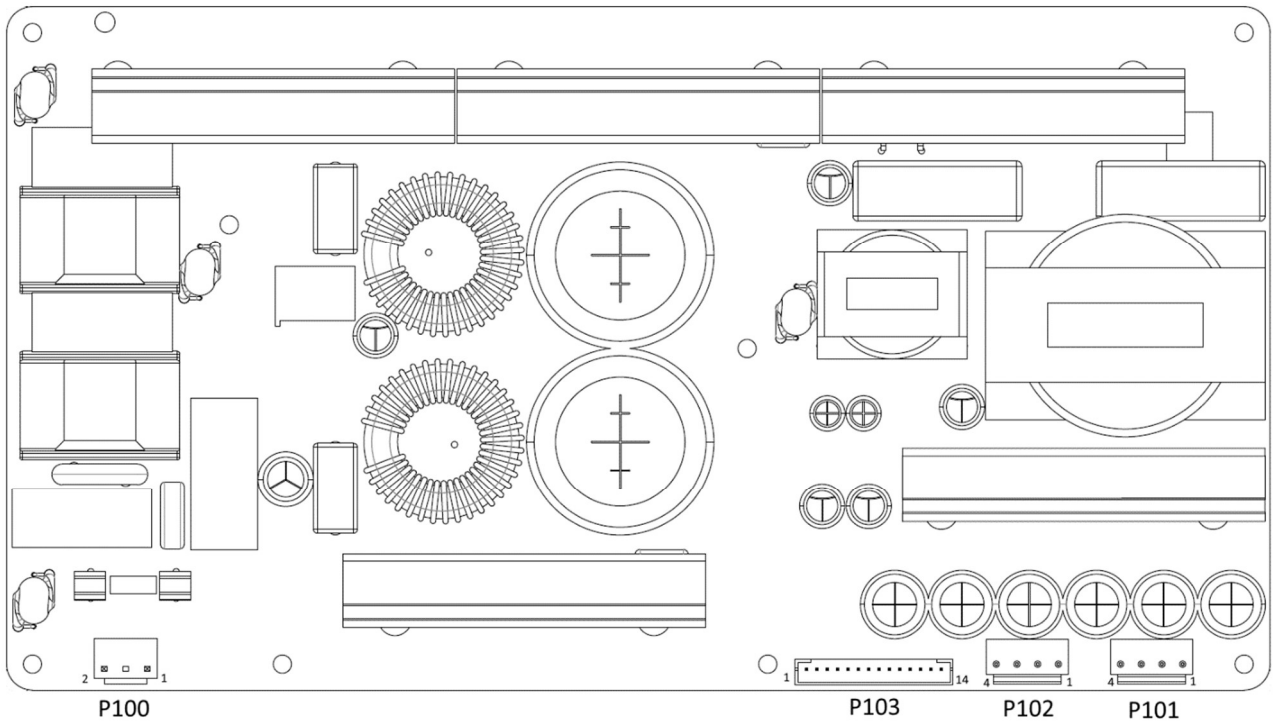

Figure 2 : ICEpower 1500S connector overview

## 6.1 P100: AC Mains Connector

<b>Type: JST, B2P3-VH (LF)(SN)</b>			
Pin	Function	Description	Type
1	Neutral	Neutral AC	Mains input
2	Live	Live AC	Mains input

Table 1: AC Mains Connector

## 6.2 P101/P102: Hanger Rail Supply Connector

<b>Type: JST, B4P-VH(LF)(SN)</b>				
Pin	Function	Description	Type	Reference
1	VD	Positive amplifier DC rail supply	Power output	GND A
2	GND A	Power Ground	GND	
3	VS	Negative amplifier DC rail supply	Power output	GND A
4	Vdrive	Vdrive supply	Power output	Vs

Table 2: Hanger Rail Supply Connector

## 6.3 P103: Control Connector

<b>Type: JST, B14B-PH-K-S (LF)(SN)</b>				
Pin	Function	Description	Type	Reference
1	DVDD	Control auxiliary supply	Power output	GND A
2	GND A	GND A	GND	
3	DVDD	Control auxiliary supply	Power output	GND A
4	DVDD	Control auxiliary supply	Power output	GND A
5	AVDD	Positive analog auxiliary supply	Power output	GND A
6	GND A	GND A	GND	
7	AVSS	Negative analog auxiliary supply	Power output	GND A
8	Power_OVL	Module overload protection indicator	Status output open collector, active low	GND A
9	PSU_OK	Power Good	Status output, active high	GND A
10	PSU_Enable	Module Enable	Control input, active high	GND A
11	Temp	Module temperature monitor	Analog Output	GND S
12	GND S	GND return for temperature monitor output	GND	
13	AC_Failure	AC Power Fail	Status output open collector, active low	GND A
14	GND A	GND A	GND	

Table 3: Control Connector

## 7 Absolute Maximum Rating

Symbol	Parameter	Min	Max	Units
$V_{ac}$	Mains input voltage (safety test) – <b>Note 1</b>	85	264	$V_{RMS}$
$f_{mains}$	Mains frequency	45	65	Hz
$V_{control}$	Control inputs voltage	GND - 0.7	25	V
$V_{status}$	Status output external pull up voltage	GND - 0.7	DVDD + 0.7	V
$I_{status}$	Status output sink current	0	20	mA

Table 4: Absolut maximum ratings

**Note 1:** The maximum operating/usage mains voltage is 240 Vac and the minimum operating/usage mains voltage is 100 Vac.

## 8 Electrical Specifications

Unless otherwise specified:

- A fan with 70 cfm is used to cool the module.
- Resistive load is used to emulate a power amplifier.
- $T_a = 25\text{ °C}$ , 230 Vac / 50 Hz mains
- Full load on aux means all aux outputs are loaded with the maximum current as specified in 8.7, except for DVDD which is loaded with 3,8 A, in order to limit the total aux power to 60 W.



## 8.1 Power

Symbol	Parameter	Condition	Min	Typ	Max	Unit
$P_o$	Rated combined Vd/Vs output power	$f_{in} = 1 \text{ kHz}$ , 60 W aux load 230 V <sub>ac</sub> / 50 Hz 120 V <sub>ac</sub> / 60 Hz 100 V <sub>ac</sub> / 50 Hz		1500 1500 1200		W
$t_{P_{max}}$	Duration of rated combined Vd/Vs output power 1500S-47V version	$f_{in} = 1 \text{ kHz}$ , no fan, No preheating, 60 W aux load 230 V <sub>ac</sub> / 50 Hz, $P_o=1500W$ 120 V <sub>ac</sub> / 60 Hz, $P_o=1500W$ 100 V <sub>ac</sub> / 50 Hz, $P_o=1200W$		190 190 290		s
$t_{P_{max}}$	Duration of rated combined Vd/Vs output power 1500S-69V version	$f_{in} = 1 \text{ kHz}$ , no fan, No preheating, 60 W aux load 230 V <sub>ac</sub> / 50 Hz, $P_o=1500W$ 120 V <sub>ac</sub> / 60 Hz, $P_o=1500W$ 100 V <sub>ac</sub> / 50 Hz, $P_o=1200W$		330 265 275		s
$P_{o\_peak}$	Peak power at 20 Hz	Combined peak output power from Vd/Vs while loaded with an amplifier playing 20 Hz sine wave output 230 V <sub>ac</sub> / 50 Hz 120 V <sub>ac</sub> / 60 Hz 100 V <sub>ac</sub> / 50 Hz		2400 2400 2300		W
$P_{o\_con\_fan}$	Continuous combined Vd/Vs output power without thermal shutdown	Mounted in chassis w. fan, 60 W aux load, Temp outside chassis = 25 °C Greatly dependent on chassis and fan airflow/design 230 V <sub>ac</sub> / 50 Hz 120 V <sub>ac</sub> / 60 Hz 100 V <sub>ac</sub> / 50 Hz		700 700 600		W
$P_{o\_con}$	Continuous combined Vd/Vs output power without thermal shutdown 1500S-47V version	Mounted on standoffs horizontal on plain surface, no fan, 60 W aux load, $T_a = 25 \text{ °C}$ 230 V <sub>ac</sub> / 50 Hz 120 V <sub>ac</sub> / 60 Hz 100 V <sub>ac</sub> / 50 Hz		390 390 380		W
$P_{o\_con}$	Continuous combined Vd/Vs output power without thermal shutdown 1500S-69V version	Mounted on standoffs horizontal on plain surface, no fan, 60 W aux load, $T_a = 25 \text{ °C}$ 230 V <sub>ac</sub> / 50 Hz 120 V <sub>ac</sub> / 60 Hz 100 V <sub>ac</sub> / 50 Hz		560 560 550		W
$I_{o\_max}$	Peak output current 1500S-47V	(Output current limited) Corresponding to ~2400 W from Vd/Vs		26		A <sub>p</sub>
	Peak output current 1500S-57V	(Output current limited) Corresponding to ~2400 W from Vd/Vs		21		A <sub>p</sub>
	Peak output current 1500S-69V	(Output current limited) Corresponding to ~2400 W from Vd/Vs		17.5		A <sub>p</sub>

Table 5: Power performance

## 8.2 Control and Status

Symbol	Parameter	Conditions	Min	Typ	Max	Units
V <sub>control</sub>	Control input voltage range		0		DVDD	V
V <sub>control_low</sub>	Control input low signal				0.8	V
V <sub>control_high</sub>	Control input high signal		2.5			V
Z <sub>control</sub>	Control input impedance	Internal pull down		50		kOhm
V <sub>status</sub>	Status output voltage range	Open collector, external pull up	0		DVDD	V
V <sub>status_low</sub>	Status output low	I <sub>out</sub> = 1mA		0.5		V
I <sub>status</sub>	Status output sink current		0		20	mA
Z <sub>status</sub>	Status output series impedance			240		Ohm
V <sub>PSU-OT-limit</sub>	PSU over temperature limit (shut down)			1.385		V
V <sub>Temp_47V</sub>	Temperature monitor output		1.385 (~97°C)		2.6 (~23°C)	V

Table 6: Control and Status specifications

## 8.3 Timing

For detailed description of the below listed timing values, please consult Section 0 of this datasheet.

Symbol	Parameter	Conditions	Min	Typ	Max	Units
t <sub>Mains-PSU_OK-set</sub>	Mains input – PSU_OK delay	PSU_Enable high P <sub>o</sub> = 400 W, Full aux load		5		s
t <sub>Mains-PSU_OK-hold</sub>	Mains input – PSU_OK hold time	PSU_Enable high P <sub>o</sub> = 400 W, Full aux load		27		ms
t <sub>Mains-Aux-set</sub>	Mains input – aux supply delay	PSU_Enable Low Full aux load		4,5		s
t <sub>Mains-Aux-hold</sub>	Mains input – aux supply hold time	PSU_Enable Low Full aux load		0,9		s
t <sub>Dis-PSU_OK-set</sub>	Disabled mode set delay	PSU_Enable low (idle) P <sub>o</sub> = 400 W, Full aux load		25		ms
t <sub>Dis-PSU_OK-release</sub>	Disabled mode release delay	PSU_Enable high (on) Full aux load		0,2	1	s
t <sub>Power_OVL-PSU_OK-release</sub>	PSU_OK (from high/active to low/not active) release delay	From P <sub>o</sub> = 400 W to 2000 W, 230 V <sub>ac</sub> / 50 Hz  From P <sub>o</sub> = 400 W to 1700 W, 120 V <sub>ac</sub> / 60 Hz		10  6		ms
t <sub>Power_OVL-PSU_OK-set</sub>	PSU_OK (from low/not active to high/active) set delay	From P <sub>o</sub> = 2000 W to 400 W, 230 V <sub>ac</sub> / 50 Hz  From P <sub>o</sub> = 1700 W to 400 W, 120 V <sub>ac</sub> / 60 Hz		17  17		ms
t <sub>Mains-AC_Failure-set</sub>	Mains input – AC_Failure set time	PSU_Enable high P <sub>o</sub> = 400 W, Full aux load		16		ms
t <sub>Mains-AC_Failure-release</sub>	Mains input – AC_Failure release time	PSU_Enable high P <sub>o</sub> = 400 W, Full aux load		1		ms

Table 7: Timing specifications

## 8.4 Power Supply - Main Output - 47V variant

Symbol	Parameter	Condition	Min	Typ	Max	Unit
V <sub>VD</sub>	Positive hanger supply, output voltage			46,5		V
I <sub>VD</sub>	Positive hanger supply, output current		26			A
C <sub>VD</sub>	VD external decoupling capacitor				24000	uF
Ripple <sub>VD</sub>	Voltage ripple on VD <b>(Note 2)</b>	Full load, P <sub>o</sub> on VD/VS		350		mVpp
V <sub>VS</sub>	Negative hanger supply, output voltage			-46,5		V
I <sub>VS</sub>	Negative hanger supply, output current				-26	A
C <sub>VS</sub>	VS external decoupling capacitor				24000	uF
Ripple <sub>VS</sub>	Voltage ripple on VS <b>(Note 2)</b>	Full load, P <sub>o</sub> on VD/VS		350		mVpp

Table 8: Power specifications – 47V variant

**Note 2:** Measured with 20MHz BW limited oscilloscope with a short GND loop directly on output connector. No external capacitance.

## 8.5 Power Supply - Main Output - 57V variant

Symbol	Parameter	Condition	Min	Typ	Max	Unit
V <sub>VD</sub>	Positive hanger supply, output voltage			57		V
I <sub>VD</sub>	Positive hanger supply, output current		21			A
C <sub>VD</sub>	VD external decoupling capacitor				16000	uF
Ripple <sub>VD</sub>	Voltage ripple on VD <b>(Note 2)</b>	Full load, P <sub>o</sub> on VD/VS		350		mVpp
V <sub>VS</sub>	Negative hanger supply, output voltage			-57		V
I <sub>VS</sub>	Negative hanger supply, output current				-21	A
C <sub>VS</sub>	VS external decoupling capacitor				16000	uF
Ripple <sub>VS</sub>	Voltage ripple on VS <b>(Note 2)</b>	Full load, P <sub>o</sub> on VD/VS		350		mVpp

Table 9: Power specifications – 57V variant

**Note 2:** Measured with 20MHz BW limited oscilloscope with a short GND loop directly on output connector. No external capacitance.

## 8.6 Power Supply - Main Output - 69V variant

Symbol	Parameter	Condition	Min	Typ	Max	Unit
$V_{VD}$	Positive hanger supply, output voltage			69		V
$I_{VD}$	Positive hanger supply, output current		17.5			A
$C_{VD}$	VD external decoupling capacitor				12000	uF
Ripple $_{VD}$	Voltage ripple on VD <b>(Note 2)</b>	Full load, $P_o$ on VD/VS		350		mVpp
$V_{VS}$	Negative hanger supply, output voltage			-69		V
$I_{VS}$	Negative hanger supply, output current				-17.5	A
$C_{VS}$	VS external decoupling capacitor				12000	uF
Ripple $_{VS}$	Voltage ripple on VS <b>(Note 2)</b>	Full load, $P_o$ on VD/VS		350		mVpp

Table 10: Power specifications – 69V variant

**Note 2:** Measured with 20MHz BW limited oscilloscope with a short GND loop directly on output connector. No external capacitance.

## 8.7 Power Supply - Auxiliary Outputs

Symbol	Parameter	Condition	Min	Typ	Max	Unit
V <sub>DVDD</sub>	Control aux supply, output voltage	I <sub>DVDD</sub> < 4.0 A	7	9	12	V
I <sub>DVDD</sub>	Control aux supply, output current <b>(Note 3)</b>	(Output current limited)			6	A
C <sub>DVDD</sub>	DVDD external decoupling capacitor				2000	uF
Ripple <sub>DVDD</sub>	Voltage ripple on DVDD <b>(Note 2)</b>	Full load on all aux outputs		400		mVpp
V <sub>AVDD</sub>	Positive analog auxiliary supply, output voltage	50mA < I <sub>AVDD</sub> < 1250 mA		7		V
I <sub>AVDD</sub>	Positive analog auxiliary supply, output current <b>(Note 3)</b>	(Output current limited)	50		1250	mA
C <sub>AVDD</sub>	AVDD external decoupling capacitor				680	uF
Ripple <sub>AVDD</sub>	Voltage ripple on AVDD <b>(Note 2)</b>	Full load on all aux outputs		700		mVpp
V <sub>AVSS</sub>	Negative analog auxiliary supply, output voltage	-50mA < I <sub>AVSS</sub> < -900 mA		-7		V
I <sub>AVSS</sub>	Negative analog auxiliary supply, output current <b>(Note 3)</b>	(Output current limited)	-900		-50	mA
C <sub>AVSS</sub>	AVSS external decoupling capacitor				680	uF
Ripple <sub>AVSS</sub>	Voltage ripple on AVSS <b>(Note 2)</b>	Full load on all aux outputs		650		mVpp
V <sub>Vdrive</sub>	Hanger drive supply, output voltage		V <sub>VS</sub> +	V <sub>VS</sub> + 12	V <sub>VS</sub> +	V
C <sub>Vdrive</sub>	Hanger drive external decoupling capacitor				680	uF
I <sub>Vdrive</sub>	Hanger drive supply, output current <b>(Note 3)</b>				850	mA
Ripple <sub>Vdrive</sub>	Voltage ripple on Vdrive <b>(Note 2)</b>	Full load on all aux outputs		75		mVpp

Table 11: Power specifications – Auxiliary

**Note 3:** The sum of the power consumption on the DVDD, AVDD, AVSS, and Vdrive supply outputs must not exceed 60 W.

**Note 2:** Measured with 20MHz BW limited oscilloscope with a short GND loop directly on output connector. No external capacitance.

## 8.8 Power Supply - Common

Symbol	Parameter	Condition	Min	Typ	Max	Unit
$P_{idle}$	Module idle consumption,	No load on all outputs		16,0		W
$P_{main\_disabled}$	Module idle consumption, Main converter Disabled	$P_{aux} = \text{No load}$		3,6		W
$P_{main,400}$	Module consumption at $P_o = 450 \text{ W}$	Full load on all aux outputs. $P_{out} = 450 \text{ W}$ .		615		W
$P_{main,full\ load}$	Module consumption at full load	Full load on all aux outputs. $P_{out} = 1500 \text{ W}$ .		1690		W
$\eta_{Total}$	Module power efficiency	$P_{changer} = 450 \text{ W}$ , Full load on all aux outputs.		91		%
$\eta_{AUX}$	Aux converter power efficiency	Full load on all aux outputs.		81		%
PF	Power factor	$P_{out} = 450 \text{ W}$ , Full load on all aux outputs.		0,94		
		$P_{out} = 1500 \text{ W}$ , Full load on all aux outputs. 230 V <sub>ac</sub> / 50 Hz 120 V <sub>ac</sub> / 60 Hz		0,98 0,99		
$I_{Inrush}$	Inrush current	V <sub>AC</sub> = 264 V		15		Ap
$I_{VAC}$	Mains current ( <b>Note 4</b> )	Full load on all aux outputs. 230 V <sub>ac</sub> / 50 Hz, $P_{out} = 1500 \text{ W}$		7,5		Arms
		120 V <sub>ac</sub> / 60 Hz, $P_{out} = 1500 \text{ W}$		15		
		100 V <sub>ac</sub> / 50 Hz, $P_{out} = 1200 \text{ W}$		14,5		

Table 12: Power specifications - Common

**Note 4:** F200 fuse rating of module is 250VAC T12A\_H. Fuse is not user replaceable.

# 9 Mechanical Specification

## 9.1 Dimensions

Symbol	Parameter	Condition	Min	Typ	Max	Unit
L	Module length			244		mm
W	Module width			132		mm
H	Module height				68	mm
Mass	Weight			1250		g

Table 13: Mechanical dimensions

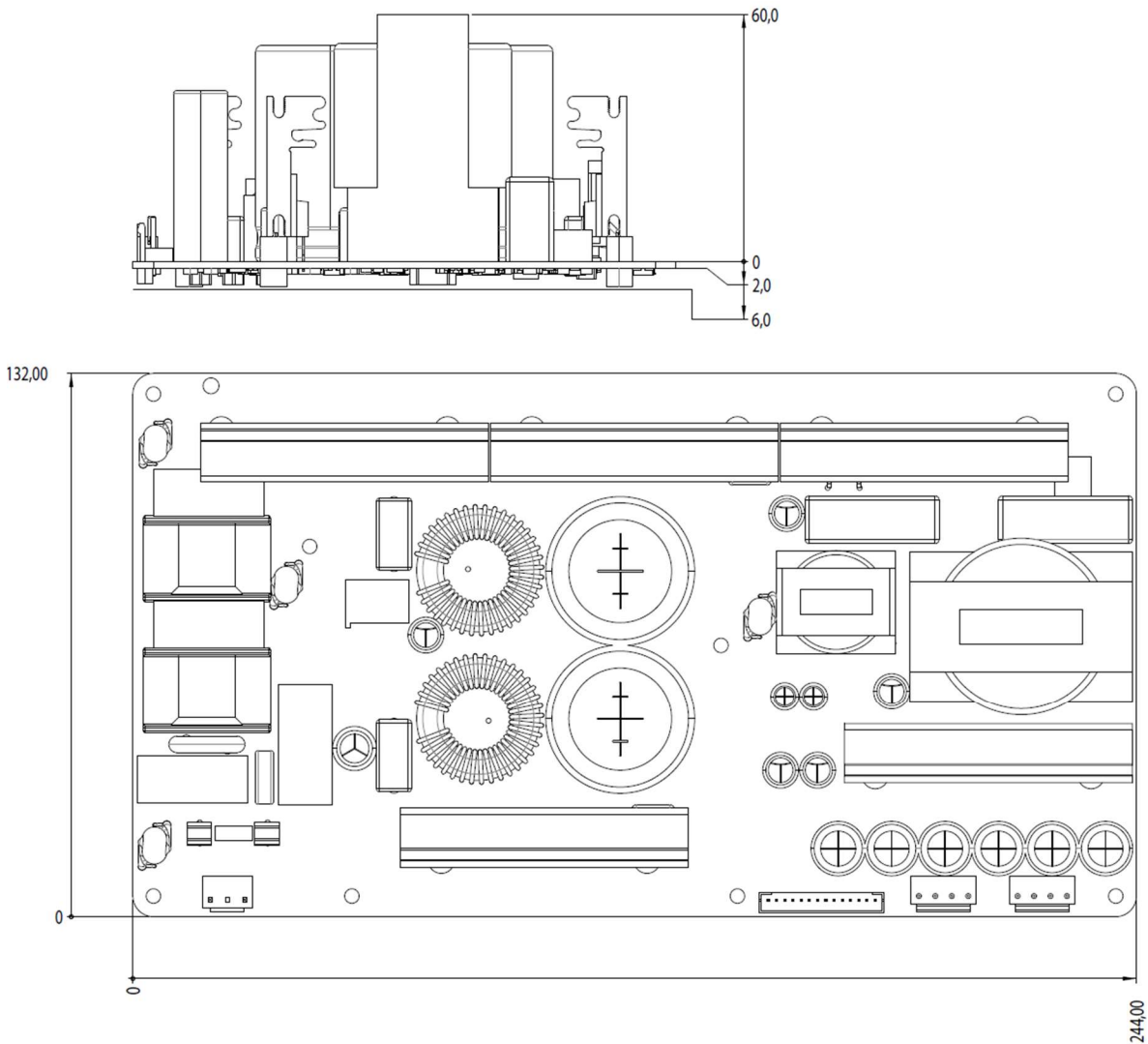

## 9.2 Mounting Holes

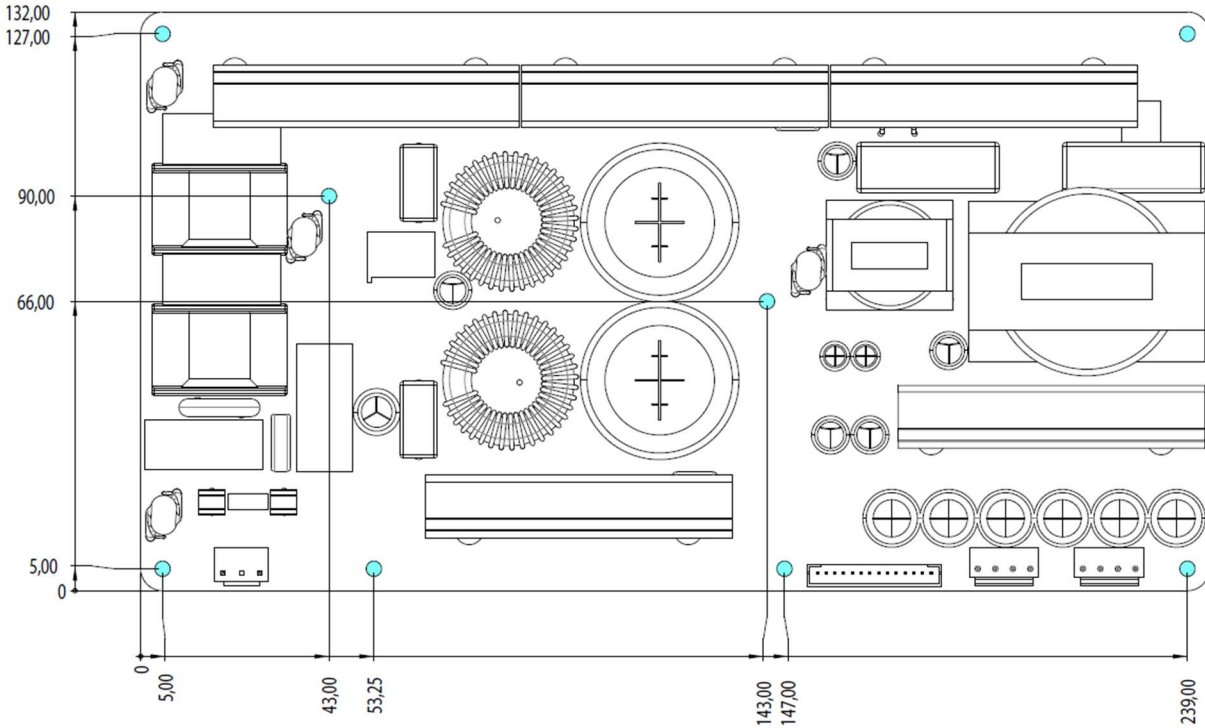

Figure 3: ICEpower 1500S Mounting holes.

**Heatsinks HS1-4 on 1500S are not isolated from mains, so the heatsinks may not be connected to any chassis or ground potential!**

Minimum 8 mm spacers/standoffs are recommended for mounting in order to ensure a proper safety clearance between module and chassis (minimum 5 mm spacers/standoffs if safety isolation foil (for example 0.43 mm Lexan FR 700 Film) is applied between bottom of PCB and mounting plate/chassis).

## 9.3 Environmental Specifications

Symbol	Parameter	Conditions	Min	Typ	Max	Units
T <sub>operating</sub>	Ambient temperature, operating	End-customer use cases	0		40	°C
T <sub>storage</sub>	Ambient temperature, storage	End-customer use cases	-40		70	°C
T <sub>shelf</sub>	Ambient temperature, shelf	Storage before goods sold to end-customer	0		50	°C
RH	Relative humidity	Non-condensing Operating and storage			85	%
	Altitude, operating				2000	m

Table 14: Environment specifications



## 9.4 Mechanical and Environmental Tests

ICEpower 1500S has undergone extensive environmental testing including Highly Accelerated Life Test (HALT).

<b>Test</b>	<b>Acceleration</b>	<b>Amount</b>
Random vibration	2.1 <i>grms</i> , random profile composed of 5 frequencies in the range 5 Hz to 275 Hz	3 perpendicular directions 3 x 20 min. + 3 x 10 min. + 3 x 10 min.
Shock	40 g / 26 ms to 70 g / 12 ms in steps of 10 g	6 directions, 3 shocks per direction

Table 15: Mechanical tests

To ensure overall end-product robustness, ICEpower recommends vibration test of the final product including the ICEpower 1500S module. Excess vibration caused by e.g. insufficiently damped resonances in a mechanical chassis or extensive exposure to high sound pressure level audio from a speaker unit can damage the product.

# 10 Typical Performance Characteristics

## 10.1 Power versus mains voltage - 1500S

Load is an amplifier, Full load on Aux outputs, Ta = 25 °C.

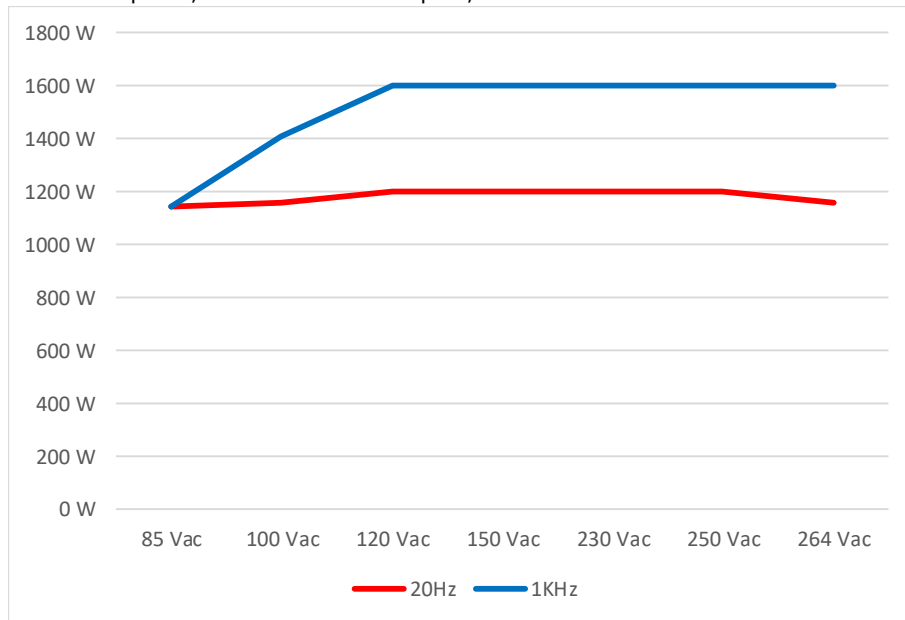

Figure 4: Output power from Vd/Vs, vs mains voltage, Audio freq. 20 Hz (red), 1kHz (blue)

## 10.2 Power Efficiency - 1500S

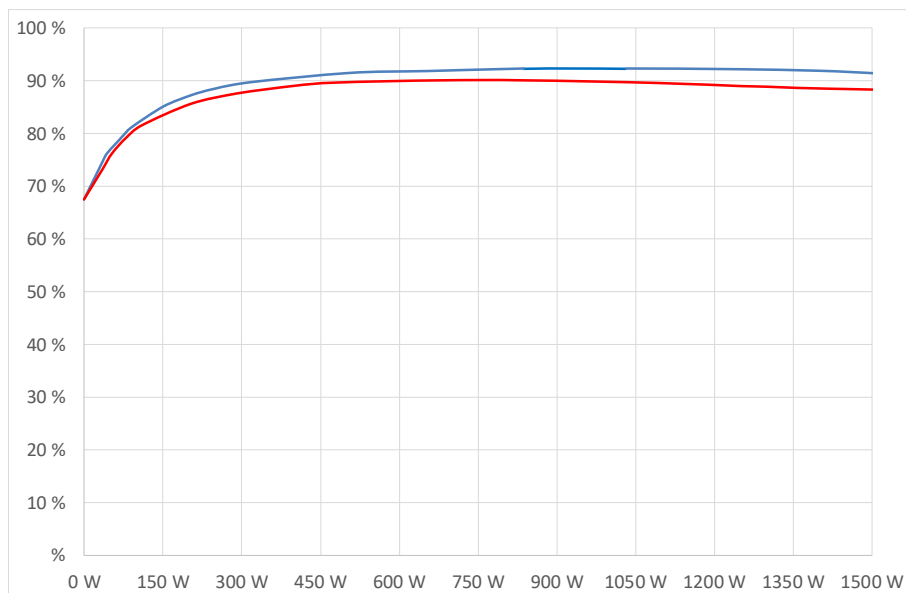

Figure 5: Power efficiency vs. output power from Vd/Vs, 230 V / 50 Hz (blue), 120 V / 60 Hz (red)

### 10.3 Dissipated Power - 1500S

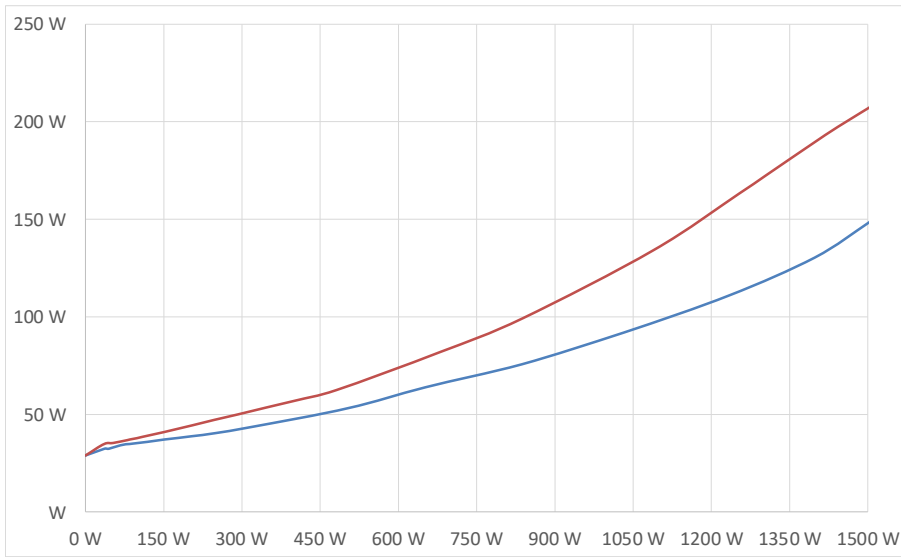

Figure 6: Dissipated power vs. output power from  $V_d/V_s$ , 230 V / 50 Hz (blue), 120 V / 60 Hz (red)

# 11 Functional Description

ICEpower 1500S will start operating in disabled mode when mains power is applied to the module with only DVDD, AVDD, AVSS and Vdrive running. Thus, to enable the main converter an external enable signal is required, or a pull-up from DVDD to PSU\_Enable. For more advanced applications, a wide set of control, status and monitoring inputs and outputs are available.

Following ICEpower's "Music at All Times" philosophy, the module will operate under all conditions except for potentially destructive situations. At power-up, the ICEpower 1500S module performs comprehensive checks to verify operation conditions and to check for errors. If an error is detected, the module will try to reboot after a short delay. As part of the effort to keep music playing, the module monitors numerous internal parameters during operation and reacts proactively if required.

The module will indicate the situation on the TEMP and Power\_OVL signals. These situations are:

- Temperature conditions close to thermal shutdown
- Power supply running at higher than specified power

Should the connected front-end not react to the situation and limit the output power sufficiently to maintain safe operation or if a potentially destructive error should occur, the ICEpower 1500S module will shut down and automatically restart after the overload situation is removed.

In the following subsections, a description is given for all ICEpower 1500S features organized per the connector in which the corresponding input or output is located.

## 11.1 AC Mains Input

ICEpower 1500S has a universal mains input operating on all common mains supplies. No switching between low and high mains is required. Additionally, the power supply includes Power Factor Correction complying with international standards.

When power is applied to the ICEpower 1500S, the module will after a short initialization read the control inputs and start operating accordingly. If the module controls are left unconnected, the module will start in disabled operation mode with only DVDD, AVDD, AVSS and Vdrive active.

The power up and power down timing is shown in Figure 7: Power up timing. PSU\_Enable pulled high. and specific timing values are available in Section 8.3.

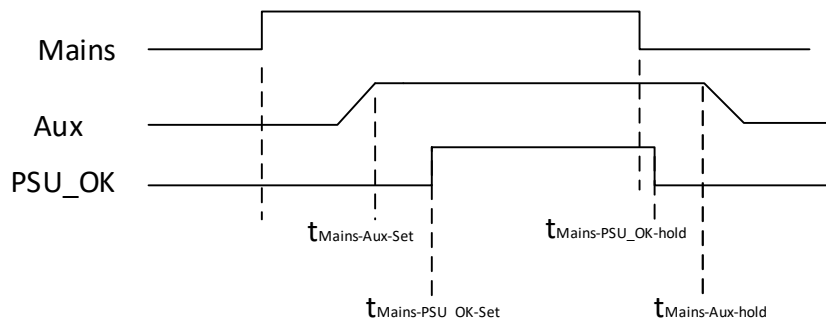

Figure 7: Power up timing. PSU\_Enable pulled high.

## 11.2 Control and Status

The Control and Status connector includes auxiliary power supply outputs for e.g. a signal front-end PCB and the following features:

- PSU\_Enable input – Active High
- Power\_OVL output – Active Low
- AC\_Failure output – Active Low
- Temp output
- PSU\_OK output – Active High
- Auxiliary voltage outputs DVDD, AVDD, AVSS and Vdrive

The recommended connection to the control input and status outputs are shown in Figure 15 and in section 12.

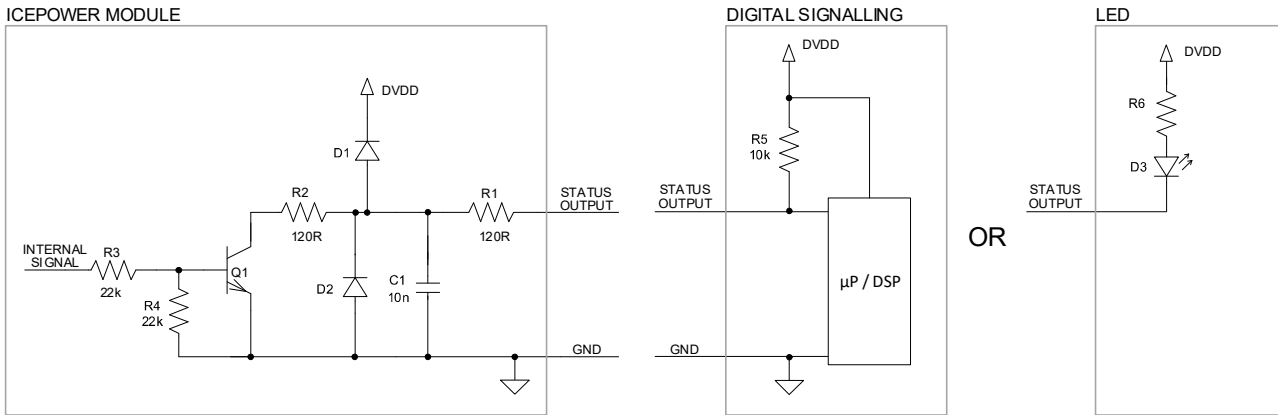

Figure 15: Status output interface schematics

### 11.2.1 PSU Enable Input

The enable input brings the ICEpower 1500S in On-mode when pulled high. An internal pull down ensures disabled operation mode if the enable input is left unconnected. Interface schematics can be found in Section 12.2.

In disabled mode, the main power converter section of the ICEpower 1500S will shut down leaving only the auxiliary power supply operating.

Timing of the enable input is shown in Figure 8: Enable timing, and specific timing / values are available in Section 8.3. Additional information on the enable input is given in Figure 8: Enable timing.

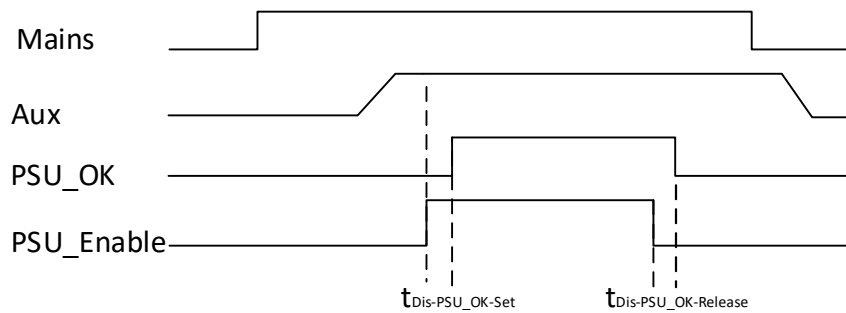

Figure 8: Enable timing

## 11.2.2 Power Overload Output

In case of potential overload situations, the ICEpower 1500S will report the event by a low level on the Power Overload output. If no action is taken by the signal front-end to limit the output power sufficiently to maintain safe operation the ICEpower 1500S will potentially shut down and resume operation after a short delay or after the overload-condition has been removed.

Events that will trigger the Power Overload output are:

- Average power over limit
- Peak power over limit

It should be noted that an overload of the control auxiliary supply will cause a full system power down.

The Power Overload output is an open-collector output pulled high by an external pull up resistor. Interface schematics can be found in Section 12.3.

Timing of the protection events are shown in Figure 9: Power\_OVL timing., and specific timing values are available in Section 8.3.

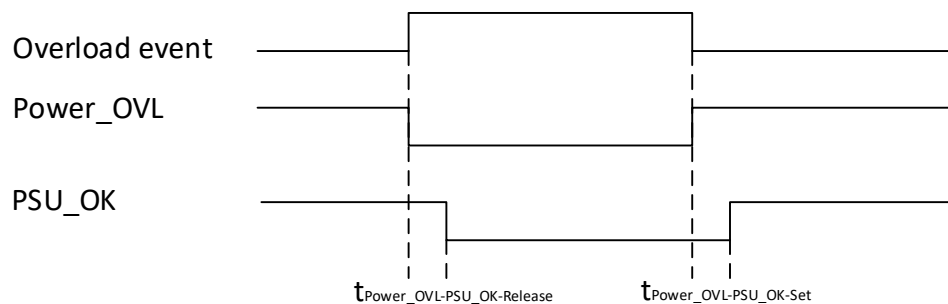

Figure 9: Power\_OVL timing.

Universal mains power supply for professional audio.

### 11.2.3 Mains Failure Output

In case of AC Power drops out, the ICEpower 1500S will report the event by a low level on the AC Power Failure output. This will continue until AC Power has been restored, though the event will only be reported for as long as the power supply decoupling on the DVDD supply can hold up the voltage.

The AC Power Failure output is an open-collector output pulled high by an external pull up resistor. Timing of the AC\_Failure output can be seen in Figure 10: AC\_Failure timing. Interface schematics can be found in Section 12.3

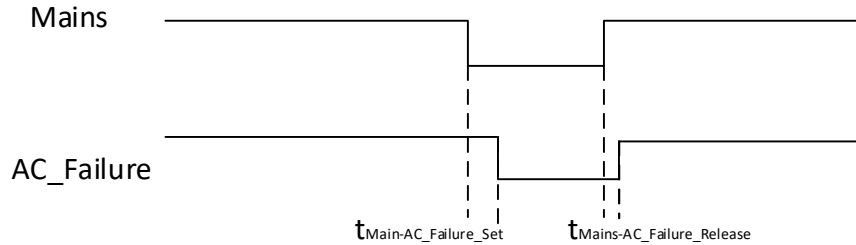

Figure 10: AC\_Failure timing.

### 11.2.4 Temperature Monitor Output

The Temperature Monitor output reports the module temperature (temperature of HS5) on a near linear scale as shown in Figure 11. The temperature reported is being measured on the secondary heatsink.

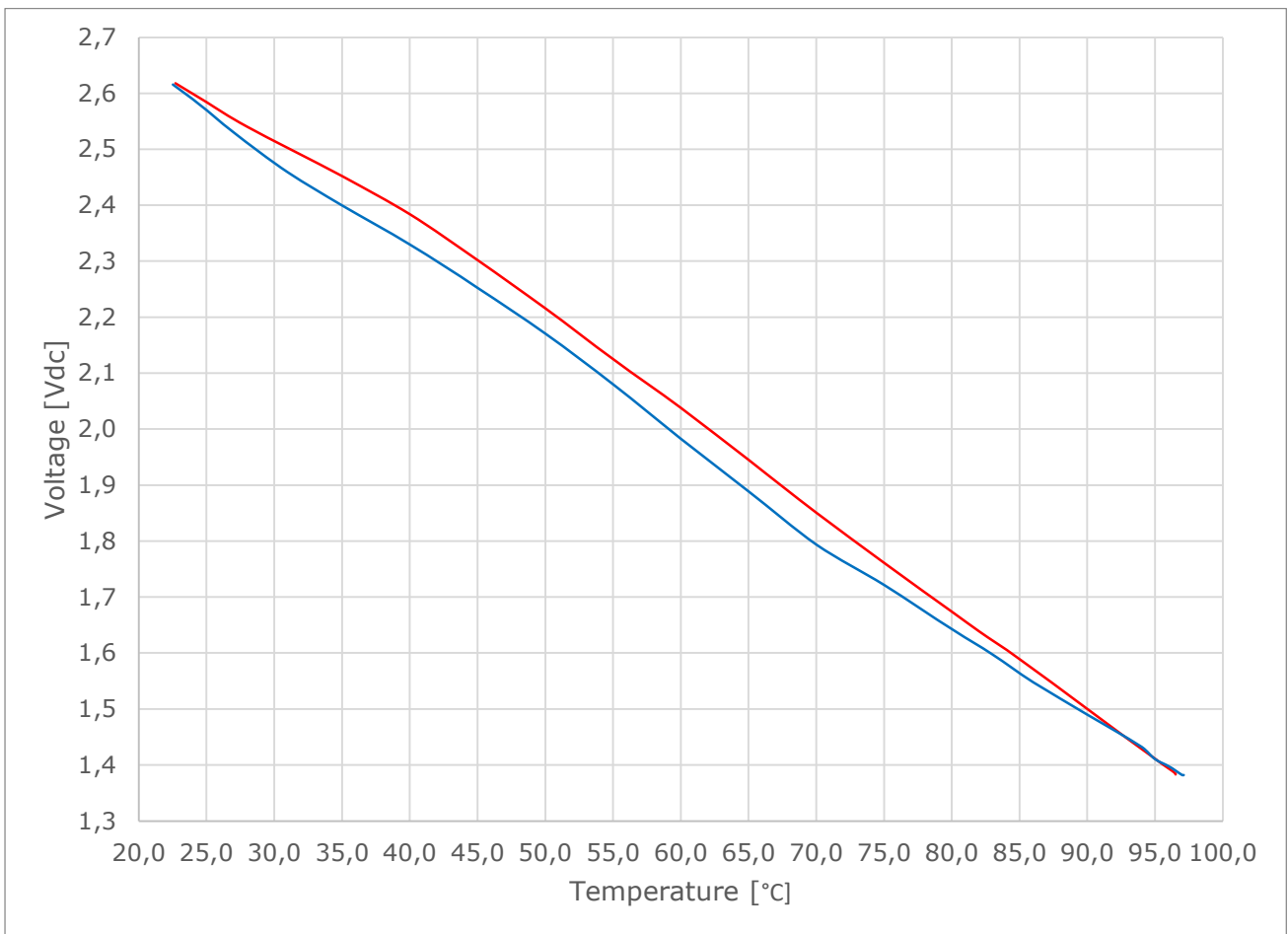

Figure 11: Typical Temperature Monitor output voltages vs temp: 1500S-69V (blue), 1500S-47V (red)

Universal mains power supply for professional audio.

Version 2.0

As a safeguard to protect against abnormal operation the primary side temperatures are measured, but not reported on the temperature monitor output. Under all normal operation conditions, the primary side components will not reach the shutdown limit.

Any measured temperature below approx. 23 °C will read out 2,6 V on the Temp output.

During thermal shutdown, the Temp output continues to report the measured temperature. The Temp output is an analog output. Interface schematics can be found in Section 12.2



Universal mains power supply for professional audio.

### 11.2.5 PSU OK Output

The PSU OK output indicates that the ICEpower 1500S is in on-mode and all voltages are up and ready for operation by a high on the PSU OK output.

The PSU OK output will go high when the ICEpower 1500S is brought out of disabled mode by the use of the PSU\_Enable input.

When power is removed from the module, when the module is brought into disabled-mode or if the module is outside of specification, the PSU OK output will be released after a short delay  $t_{\text{Mains-PSU\_OK-hold}}$ .

For the over-temperature case though, it is also required that the module temperature is brought down to a safe level again.

If the peak power limit is reached the power supply rails will be lowered and the PSU OK output will be pulled low immediately.

If the average power limit is reached the power supply rails will be lowered and the PSU OK output will be weakly pulled low through 37k after a short delay. The PSU OK output timing is shown in Figure 12: PSU\_OK Timing

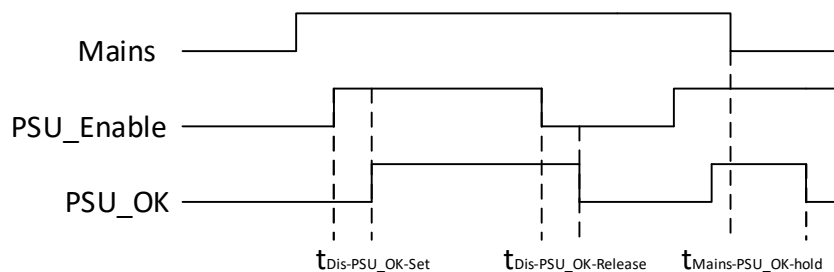

Figure 12: PSU\_OK Timing

### 11.2.6 DVDD Power Supply Output

The DVDD output is a power supply output intended for control circuits on a front-end board e.g. microcontrollers and DSPs.

It is recommended though to add extra supply line series feed impedances and decoupling capacitors on the connected PCB to attenuate the power supply voltage ripple. The series impedance can be either a low value resistor or a small inductor. The extra decoupling capacitance must not exceed the value specified in Table 11: Power specifications – Auxiliary. The DVDD output is short circuit protected. A short of this output will cause the full ICEpower 1500S module to turn off. When the short circuit condition has been removed the module will resume operation automatically after a short delay.

### 11.2.7 AVDD and AVSS Power Supply Output

The AVDD and AVSS outputs are positive and negative power supply outputs intended for analog circuits on a front-end board e.g., analog buffers and speaker crossover filters.

To ensure proper suppression of supply related noise and hum, it is important to have all supply related current draw through the GND connections in the power supply interface. For proposed grounding scheme details, please see Section 13.1

Universal mains power supply for professional audio.

The AVDD and AVSS supply outputs are loosely regulated. They may require additional voltage regulators on a front-end board depending on the type of circuit supplied by these pins. It is therefore recommended to add extra supply line series feed impedances and decoupling capacitors on the connected PCB to attenuate the power supply voltage ripple. The series impedance can be either a low value resistor or a small inductor. The extra decoupling capacitance must not exceed the value specified in Table 12: Power specifications - Common

The AVDD and AVSS outputs are short circuit protected. A short of these outputs will cause a power down of the power supply. When the short circuit condition is removed the main and auxiliary output will automatically restart after a short delay.

### 11.3 Hanger Rail Supply

To supply an amplifier on the ICEpower 1500S, the amplifier power stage positive and negative supply lines VD and VS together with Vdrive and power ground GND are available in the Hanger Rail Supply connector.

## 12 Interface Schematics

In the following sub-sections, proposed interface schematics are shown. These schematics should be considered an assistance to the design process, and they represent the recommended interface to the ICEpower 1500S module.

### 12.1 Analog Output

Interface for Temperature Monitor output.

ICEPOWER MODULE

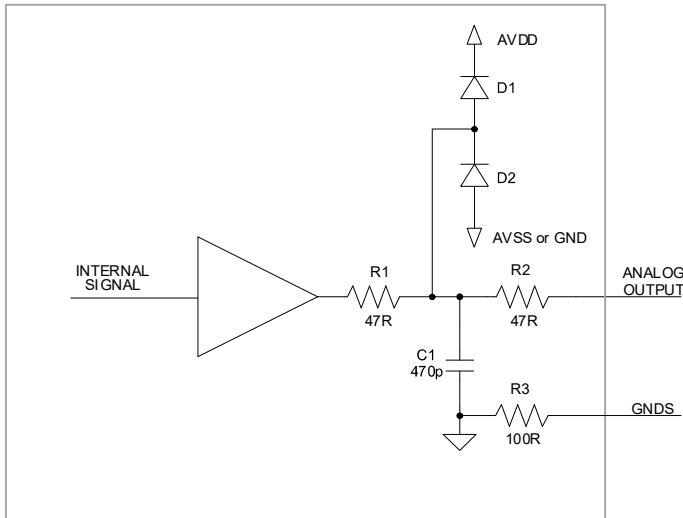

SENSE AMPLIFIER

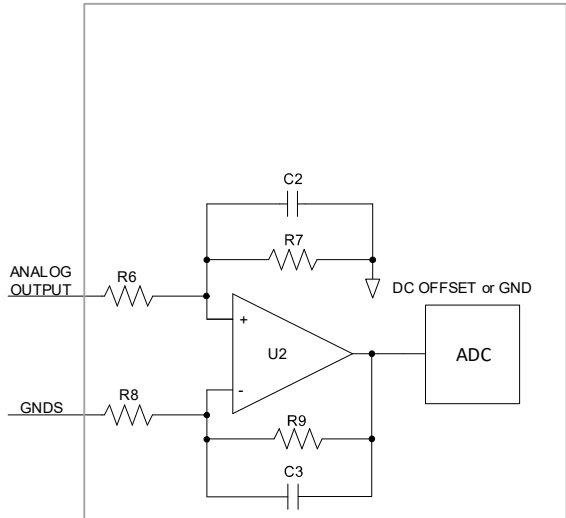

Figure 13: Analog output

## 12.2 Control Input

Generic interface for all control inputs.

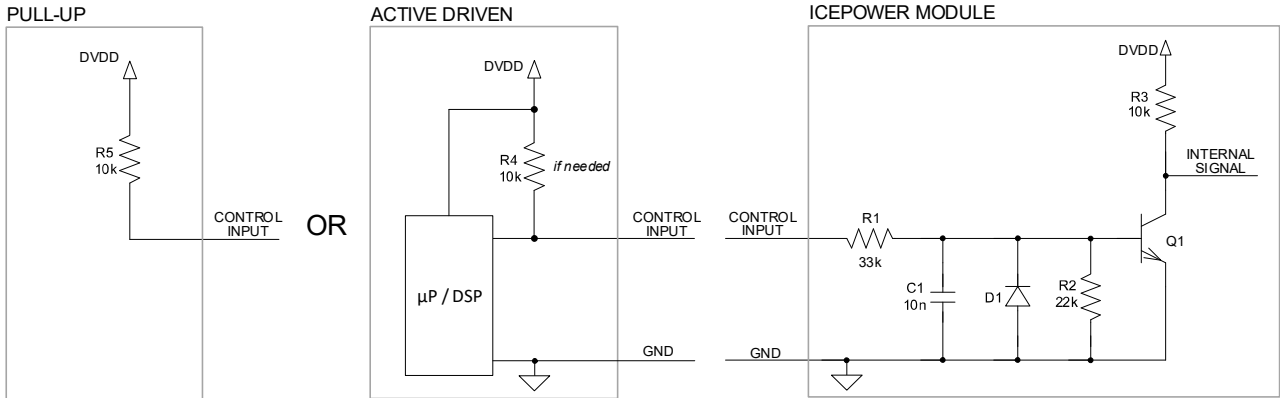

Figure 14: Control Input Schematic

## 12.3 Status Output

Generic interface for all status outputs except PSU\_OK.

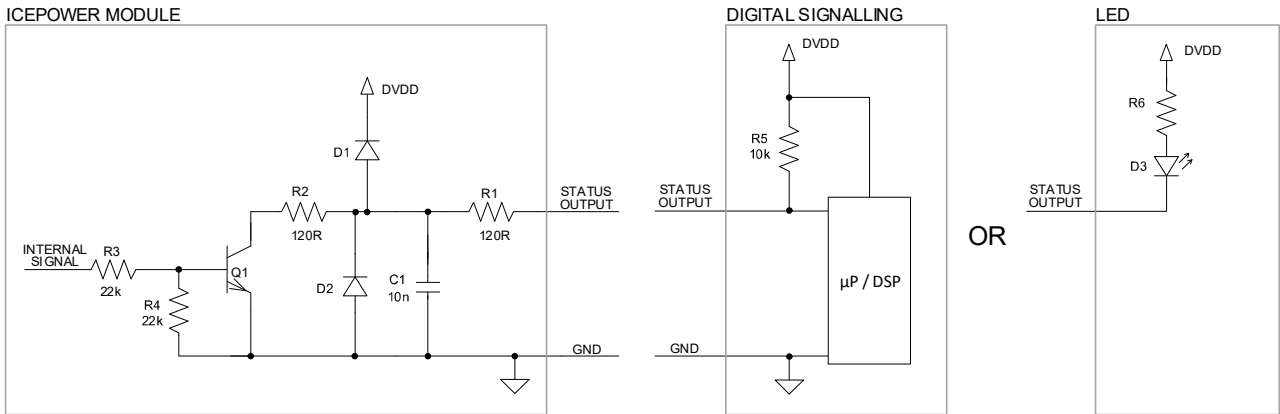

Figure 15: Status output interface schematics

## 12.4 PSU\_OK

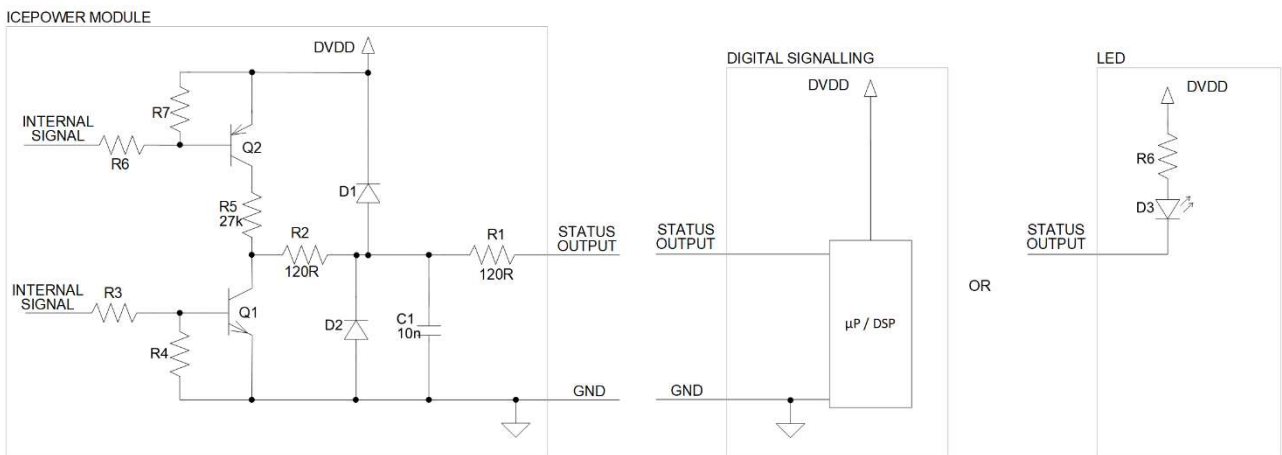

Figure 16: PSU\_OK interface schematic

# 13 Integration Guidelines

The ICEpower 1500S is designed with ease of integration in mind. This includes both electrical, EMC, thermal and mechanical integration. In the following sub-sections, recommendations will be given to assist the end-product design process.

## 13.1 Grounding Scheme

To ensure EMC and Safety compliance mounting holes W800, W801, W802, W803, W804 and W806 must electrically be connected to chassis (PE). To ensure mechanical stability W805 and W807 must also be used.

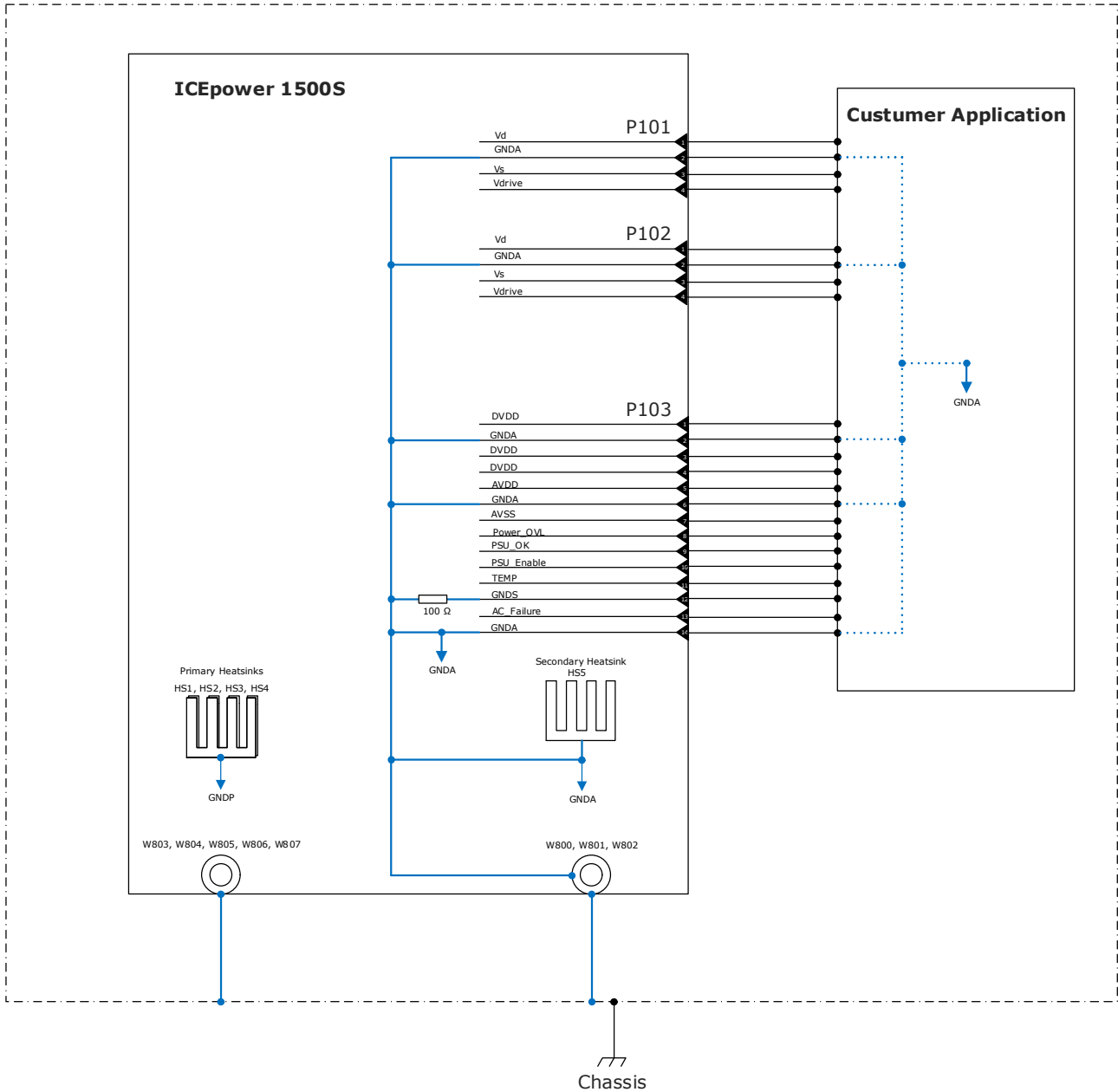

Figure 17: Grounding scheme

## 13.2 EMC Management

As described in Section 2, the ICEpower 1500S is EMC pre-approved as is when mounted on a standard aluminum open back plate. However, because of the high-power switching electronics included in the module, some EMC precautions are required to ensure an EMC approvable end-product design.

- Connect the module to the chassis. Mounting of the module isolated from the chassis may cause extended HF radiation.
- Do not use cable/wires between module and other PCBs that are longer than necessary.
- Avoid wire loops on the speaker output wires. Use wires closely paired side by side or if required use twisted or shielded cables (Figure 18)

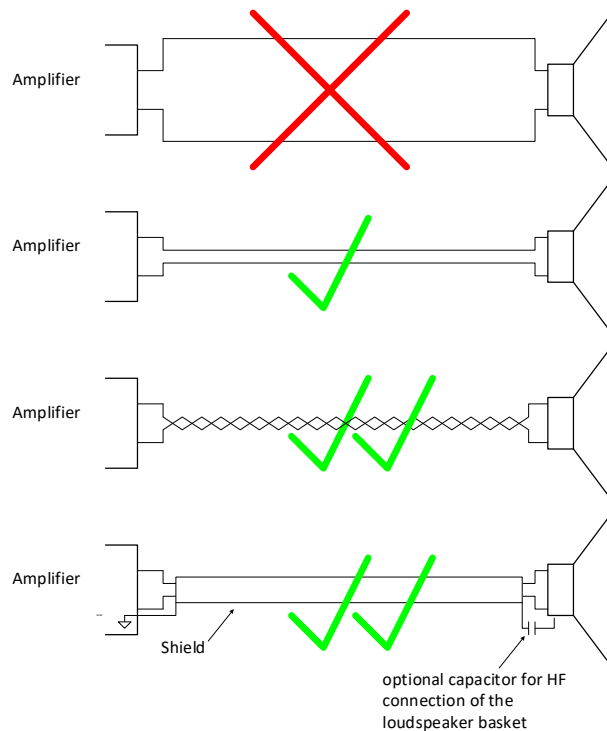

Figure 18 : Avoid wire loops on the speaker wires

- Avoid wire loops on the mains wires from the mains inlet to the module mains connector.
- Do not route cables near by the magnetic components on the module i.e. inductors and transformers (Figure 19).

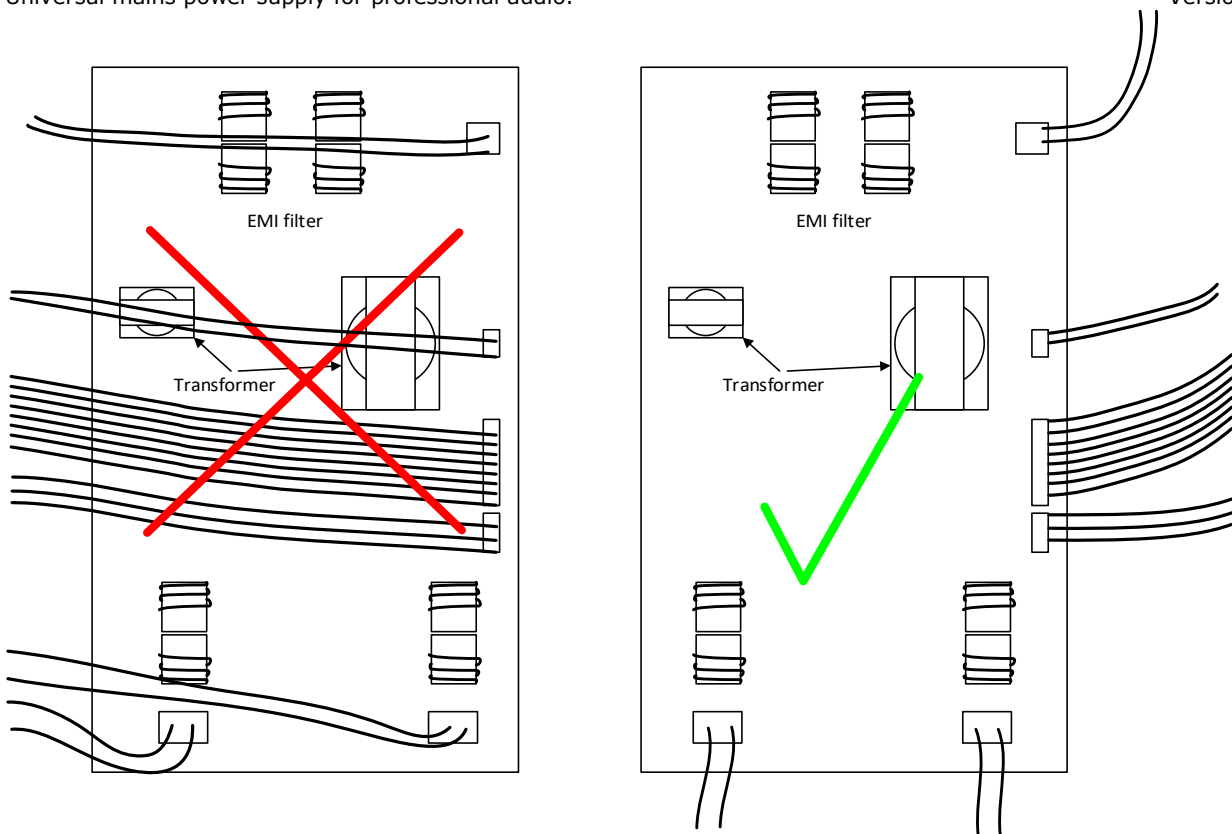

Figure 19 : Do not route cables near the module magnetics.

- Do not bundle mains wires together with other cables Figure 20.

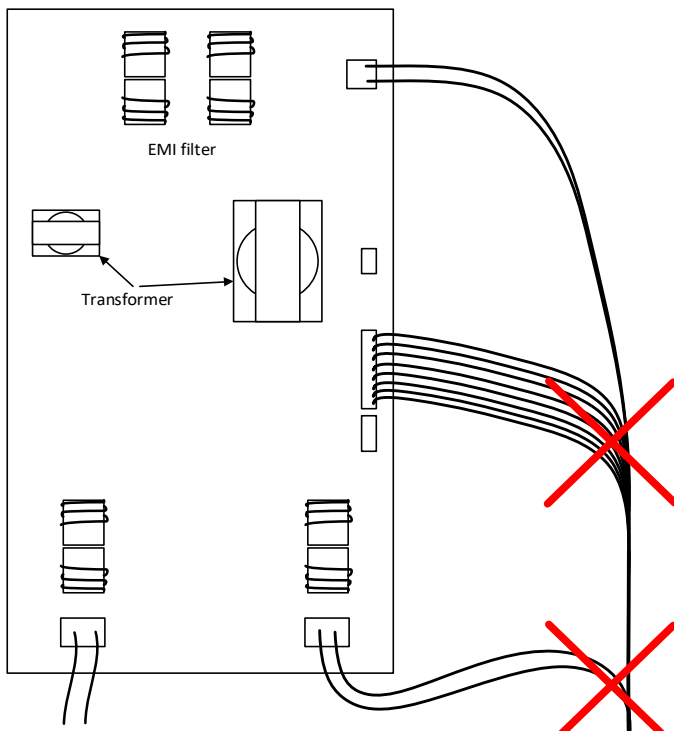

Figure 20 : Wire bundling

Universal mains power supply for professional audio.

Depending on the end-product application, additional EMC initiatives and filtering may be required to have the entire product approved. The reason for this could be, among others, inappropriate cable routing within the application or DSP/microprocessor based front-end systems.

To improve on EMC performance, it is often advisable to revisit the used grounding scheme and cable routing and add EMC filters on some or all the connectors on the end-product.

### 13.3 Thermal Design

The ICEpower 1500S module is designed with an integrated cooling system. The module can therefore operate without any further cooling however at reduced power levels. Even though use of the module without further cooling is possible, it is recommended to add active cooling to extend the continued power capabilities.

It is important to ensure proper airflow around the module. In most cases, this can be achieved through passive convection, but in some cases e.g. rack enclosures, forced airflow may be required depending on end-product mechanical design constraints or end-product use environment.

### 13.4 Safety Certification Notes

To ensure compliance with 62368-1 and 60065 it is important to adhere to the following:

- F200 fuse rating of module is 250VAC T12A\_H. Fuse is not user replaceable.
- This equipment is not suitable for use in locations where children are likely to be present.  
It is important instructions to mechanically fasten the product as followed. All mounting holes W800, W801, W802, W803, W804 and W806 shall be reliably connected to the protective earthing terminal of the end product. To ensure mechanical stability W805 and W807 must also be used.

## 14 Safety and EMC Standards

The ICEpower 1500S have been verified to conform to the following standards.

### 14.1 Safety

Following standards incl. compliance with the National requirements of AR, AT, AU, BE, CA, CN, CH, CZ, DE, DK, ES, FI, FR, GB, HU, IE, IL, IT, JP, KR, MY, NL, NO, PL, SE, SG, SK, SI and US.

EN/IEC/UL 62368-1 (2nd edition) – Class 1

IEC 60065 7<sup>th</sup> edition Amd1 + Amd2 – Class 1

### 14.2 EMC

EN/IEC 55032 (CISPR 32)	Electromagnetic compatibility of multimedia equipment – Emission requirements – Class B
EN/IEC 61000-3-2	Harmonic current emission
EN/IEC 61000-3-3	Voltage changes, voltage fluctuations and flicker
CFR 47 Part 15 Subpart B (FCC)	Telecommunication – Radio Frequency Devices – Unintentional Radiation – Class B
<i>EN/IEC 55035 (CISPR 35)</i>	Electromagnetic compatibility of multimedia equipment. Immunity requirements
EN/IEC 61000-4-2	Electrostatic discharge immunity test
EN/IEC 61000-4-3	Radiated, radio frequency, electromagnetic field immunity test
EN/IEC 61000-4-4	Electrical fast transient / burst immunity test
EN/IEC 61000-4-5	Surge immunity test
EN/IEC 61000-4-6	Immunity to conducted disturbances, induced by radio- frequency fields



## 15 ESD Warning

ICEpower products are manufactured according to the following ESD precautions:

ANSI/ESD-S20.20-2014: Protection of Electrical and Electronic Parts, Assemblies and Equipment.

Further handling of the products should comply with the same standard.

The general warranty policy of ICEpower a/s does not cover ESD damaged products due to improper handling.

## 16 Ordering, Packaging and Storage

All ICEpower modules are packaged in ESD safe bubble bags and cardboard boxes.

### 16.1 Ordering Information

Order Codes	Description	Part Number
ICEpower 1500S-47V	1500S with +/- 46.5V hanger voltage	8001504
ICEpower 1500S-57V*	1500S with +/- 57V hanger voltage	8001506
ICEpower 1500S-69V	1500S with +/- 69V hanger voltage	8001505

\* This output voltage variant and other output voltage variants will be available upon request for large order quantities.

### 16.2 Shipping Dimensions and Weight

Package	Quantity	Dimensions (w x d x h) [mm]	Gross Weight [kg]
Carton	8	318 x 295 x 305	11.2

### 16.3 Storage Conditions

#### Storage Humidity and Temperature:

Please find storage humidity and temperature information in Section 9.3, Environmental Specifications.

#### Stacking

A maximum of 4 cartons must be stacked on top of each other.

Pallets must not be stacked on top of each other.

## 17 Contact

For additional information about the ICEpower® technology from ICEpower a/s, visit our web site or contact us.

ICEpower a/s  
Vandtårnsvej 62A 3B  
DK-2860 Søborg  
Denmark

Phone +45 31 71 00 01

www.icepower.dk  
[info@icepower.dk](mailto:info@icepower.dk)

## 18 Legal Notes

ICEpower a/s believes that the information in this datasheet is accurate and reliable. However it is provided "as is" without any warranties of any kind. ICEpower a/s and its suppliers, to the fullest extent permitted by law, disclaim all warranties, including the warranty of merchantability, warranty of non-infringement of third-party rights, and the warranty of fitness for a particular purpose. ICEpower a/s and its suppliers make no warranties about the accuracy, reliability, completeness, or timeliness of the material, services, software, text, graphics and links. In no event will ICEpower a/s be liable to any party for any damages whether direct, indirect, special, consequential or other for any use or inability to use of this datasheet, including, without limitation, any damages for lost profits, business interruption, loss of programs or other data on your information handling system or otherwise, even if we are expressly advised of the possibility of such damages.

Information in this datasheet may contain technical inaccuracies or typographical errors. The information in the datasheet may be changed at any time without prior notice or obligation.

ICEpower® is a trademark of ICEpower a/s.

ICEpower a/s products are not authorized for use as critical components in life support devices or life support systems without the express written approval of the president and general counsel of ICEpower a/s. As used herein:

- Life support devices or systems are devices or systems which, (a) are intended for surgical implant into the body, or (b) support or sustain life, and whose failure to perform when properly used in accordance with instructions for use provided in the labelling, can be reasonably expected to result in a significant injury to the user.
- A critical component is any component of a life support device or system whose failure to perform can be reasonably expected to cause the failure of the life support device or system, or to affect its safety or effectiveness.

ICEpower a/s ©2020