

ICEpower a/s, Vandtårnsvej 62A 3B, DK-2860 Søborg
Phone +45 31 71 00 01, CVR-no. 25053591
info@icepower.dk, www.icepower.dk

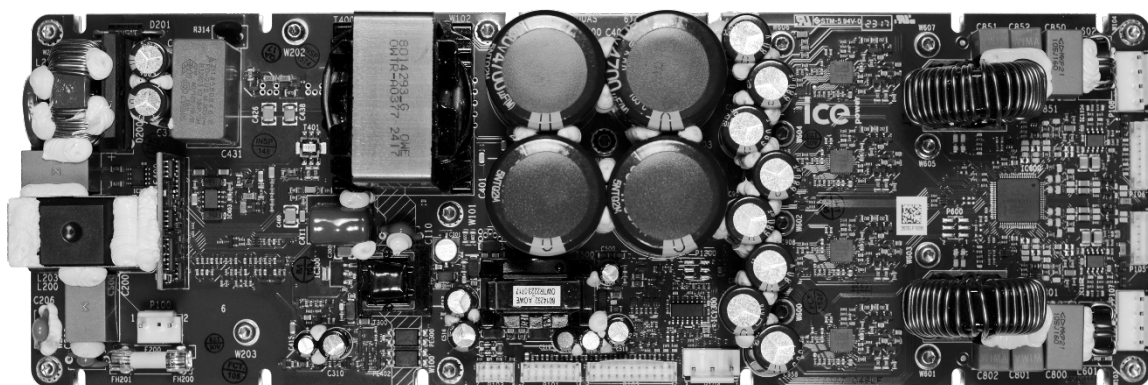

ICEpower1200AS1 ICEpower1200AS2

One and Two Channel 1200 W ICEpower Amplifiers with Integrated Universal Mains Power Supply

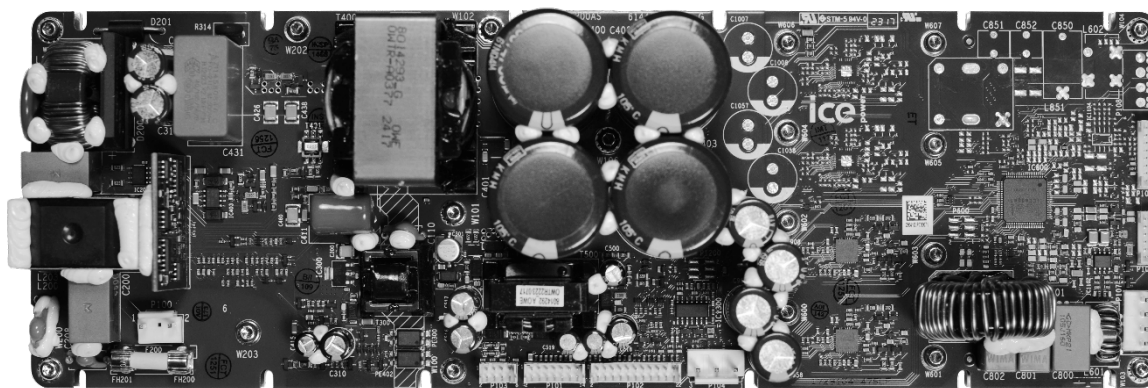

1 Contents

1	CONTENTS	2
2	GENERAL DESCRIPTION	4
2.1	Features.....	4
2.2	Key Specifications.....	4
3	DOCUMENT HISTORY	5
4	GETTING STARTED	6
5	BLOCK DIAGRAM	6
6	CONNECTORS	7
6.1	P100: AC Mains Connector.....	7
6.2	P101: Basic Control Connector.....	7
6.3	P102: Advanced Control Connector	8
6.4	P105: Audio Input Connector.....	8
6.5	P107: Channel 1 Loudspeaker Output Connector.....	9
6.6	P108: Channel 2 Loudspeaker Output Connector.....	9
6.7	P106: Voltage and Current Monitor Output Connector.....	9
6.8	P104: Hanger Rail Supply Connector.....	9
6.9	P103: Hanger Control Connector	10
7	ABSOLUTE MAXIMUM RATING.....	11
8	ELECTRICAL SPECIFICATIONS.....	11
8.1	Audio	11
8.2	Speaker Output Voltage and Current Monitors	13
8.3	Control and Status.....	13
8.4	Timing.....	14
8.5	Power Supply.....	15
9	MECHANICAL SPECIFICATION.....	17
9.1	Dimensions.....	17
9.2	Mounting Holes.....	17
9.3	Environmental Specifications.....	18
9.4	Mechanical and Environmental Tests	18
10	TYPICAL PERFORMANCE CHARACTERISTICS	19
10.1	Frequency Response.....	19
10.2	Total Harmonic Distortion	20
10.3	Idle Noise	21
10.4	Intermodulation.....	21
10.5	Channel Separation.....	22
10.6	Output Impedance.....	22
10.7	Damping Factor.....	23
10.8	Output Power vs Mains	23
10.9	Power Efficiency.....	24
10.10	Dissipated Power	24
11	FUNCTIONAL DESCRIPTION.....	25
11.1	Audio Input	25
11.2	Speaker Outputs	25
11.3	AC Mains Input.....	26
11.4	Basic Control and Status	26
11.5	Advanced Control and Status	30

11.6	Voltage and Current Monitor Outputs	33
11.7	Hanger Rail Supply	34
11.8	Hanger Control.....	34
12	INTERFACE SCHEMATICS.....	34
12.1	Audio Input	34
12.2	Analog Output.....	36
12.3	Control Input.....	36
12.4	Status Output.....	36
13	INTEGRATION GUIDELINES	37
13.1	Grounding Scheme	37
13.2	EMC Management	38
13.3	Thermal Design	38
14	MECHANICAL MOUNTING	39
15	SAFETY AND EMC STANDARDS	40
15.1	Safety	40
15.2	EMC.....	40
16	ESD WARNING.....	41
17	ORDERING, PACKAGING AND STORAGE	41
17.1	Ordering Information.....	41
17.2	Shipping Dimensions and Weight	41
17.3	Storage Conditions.....	41
18	CONTACT.....	42
19	LEGAL NOTES	42

2 General Description

ICEpower1200AS1 and ICEpower1200AS2 are two fully integrated audio power amplifier modules including universal mains ErP and Energy Star compliant power supply. ICEpower1200AS1 is a one-channel module and ICEpower1200AS2 is a two-channel module.

The ICEpower1200AS family provides comprehensive protection and monitoring functions nevertheless with an easy-to-use control interface. Additionally, dedicated monitor outputs for speaker connector output voltage and current enables real time protection system of the loudspeaker.

The integrated aluminum base plate on the 1200AS acts as both cooling and mechanical interface. This enables easy mechanical integration and extra cooling can be added.

ICEpower1200AS is EMC and safety pre-approved enabling fast design-in and minimum time to market.

2.1 Features

Fully integrated one or two channel amplifier	No need for additional circuits for simple applications
Short circuit and over-current protection	Ensures reliable and robust end-products
Real time voltage and current monitor outputs	Enables real time monitoring of speaker drivers
Comprehensive monitoring and protection	Keep track of module operating conditions and protects the module from overload
Clip monitor per channel and thermal warning outputs	Allows the end-product system to react proactively, preventing system shutdown and enabling Music at All Times
Protect status output	Indicator for module protection shutdown
Audio signal trigger and logic triggers	Automatic turn on and off in remotely located amplifiers
Auxiliary power supply output	Supply for analog and control circuits in e.g. a signal front-end and standby supply
Standby-mode	ErP (1275/2008/EC) compliant Energy Star® v3.0 compliant
Universal mains with active Power Factor Correction	No need for region specific variants
EMC and safety pre-approved	Suitable for CE and FCC approved designs
Simple yet flexible mechanical mounting	Easy mechanical integration and thermal management
ICEpower standard connector and pin definition	Allows reuse of front-end hardware
Prepared for hanger amplifier modules	Extra audio channel for e.g. 3 way active speakers

2.2 Key Specifications

- 1200 W / 4 Ohm per channel $\leq 1\%$ THD+N, 1 kHz
- 0.003 % THD+N @ 1 kHz, 10 W / 4 Ohm
- 50 kHz audio bandwidth
- 30 μ V A-weighted output noise
- Minimum load impedance at 2.7 Ohm
- Maximum output voltage / current 100 V_p / 38 A_p
- +5 V_{DC} and +/-15 V_{DC} auxiliary supply outputs
- Universal mains including Power Factor Correction (100 – 240 V, 50 – 60 Hz)
- Size (L x W x H): 300 mm x 100 mm x 63 mm, 11.8 inch x 3.94 inch x 2.48 inch
- Safety conforms to: 60065 & 62368

3 Document History

Version	Date	Revised by	Changes
1.0	2017-11-17	TOC	First release
1.1	2017-12-18	TOC	Section 8.1. 10 % power spec updated Capacitive load spec updated
1.2	2018-08-01	DIT	Visual update
1.3	2018-11-06	LBH/DIT	Absolute Maximum Ratings updated
1.4	2018-12-12	LBH/DIT	Environmental Specifications updated
1.5	2019-01-15	LBH/DIT	8.5 and Environmental Specifications updated
1.6	2020-07-01	NKK	Safety updated

4 Getting Started

ICEpower1200AS is a fully self-contained amplifier module and requires no interaction nor control to operate.

For first time use, please connect an audio source to the analog input and loudspeakers to the speaker output connectors before applying power to the AC mains input. ICEpower1200AS will start operating a few seconds after mains is applied.

5 Block Diagram

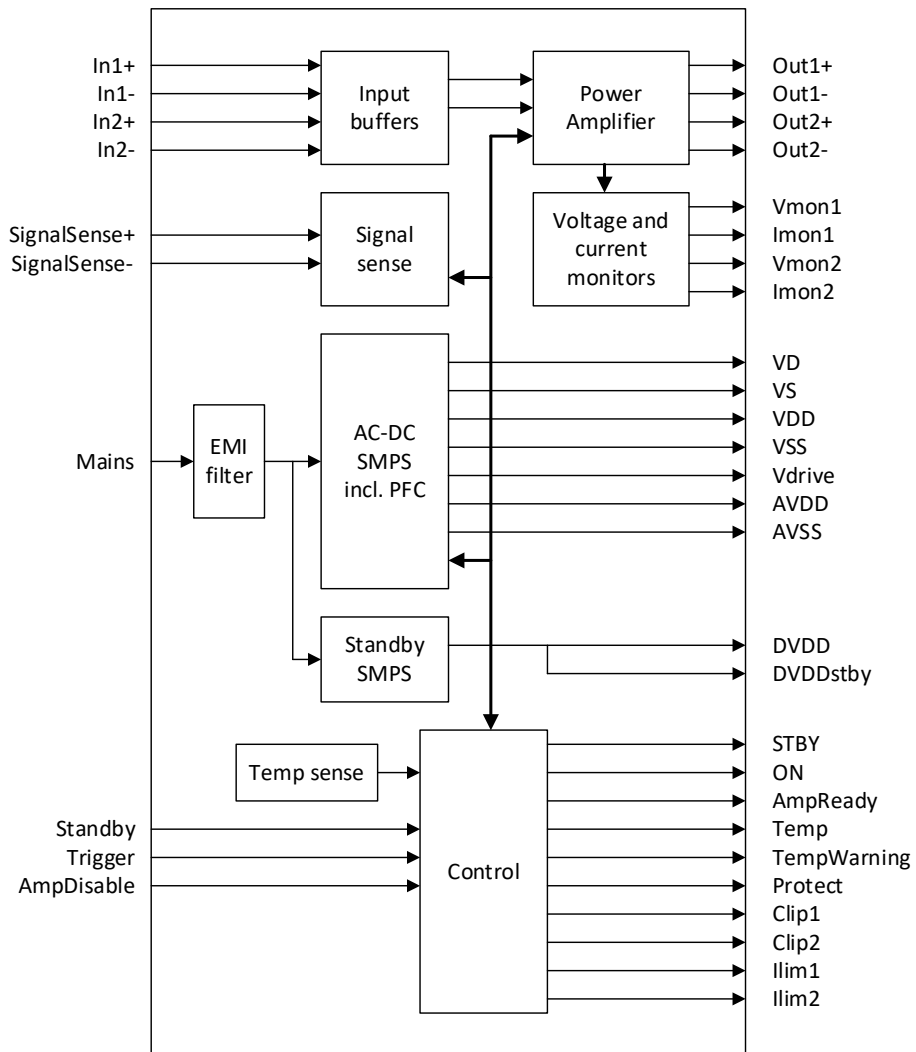

Figure 1: ICEpower1200AS block drawing

6 Connectors

ICEpower1200AS comes with industry standard connectors, selected for long-term reliability. 1200AS1 and 1200AS2 share the same PCB, but in the one channel version, 1200AS1, some of the components and Speaker Output connector P108 are not mounted.

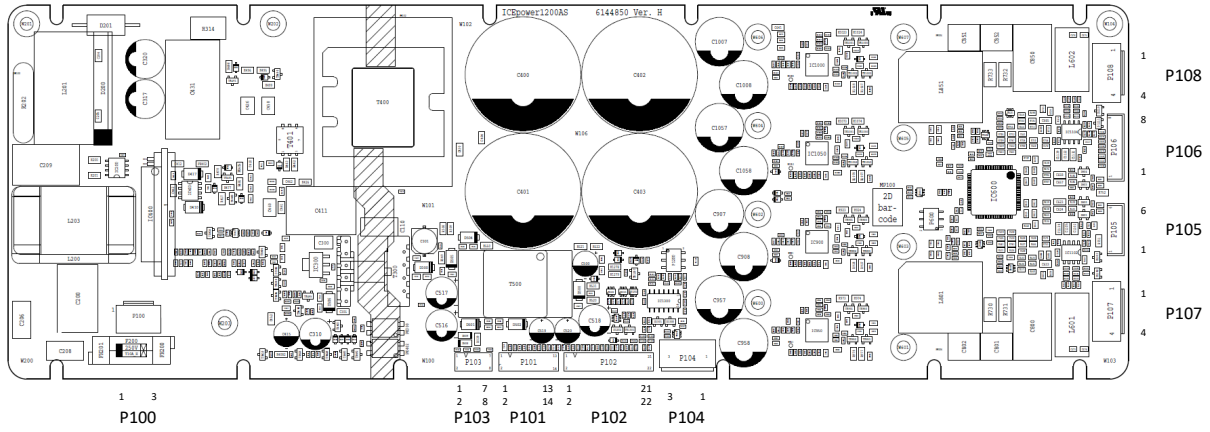

Figure 2: ICEpower1200AS connector overview

6.1 P100: AC Mains Connector

Type: JST, B2P3-VH (LF)(SN)			
Pin	Function	Description	Type
1	Neutral	Neutral AC	Mains input
2	NA	Pin Not Available	
3	Live	Live AC	Mains input

Table 1: AC Mains Connector

6.2 P101: Basic Control Connector

Type: JST, B14B-PHDS (LF)(SN)				
Pin	Function	Description	Type	Reference
1	DVDD	Control auxiliary supply	Power output	GNDaux
2	GNDaux	Auxiliary ground	GND	
3	DVDDstby	Control auxiliary standby supply	Power output	GNDaux
4	GNDaux	Auxiliary ground	GND	
5	AVDD	Positive analog auxiliary supply	Power output	GNDaux
6	Standby	Module standby	Control input, active high	GNDaux
7	AVSS	Negative analog auxiliary supply	Power output	GNDaux
8	Reserved	Not connected		
9	Clip1	Voltage clip indicator, channel 1	Status output, open collector, active low	GNDaux
10	AmpDisable	Disable amplifier (mute)	Control input, active high	GNDaux
11	Clip2	Voltage clip indicator, channel 2	Status output open collector, active low	GNDaux
12	Protect	Module protection indicator	Status output open collector, active low	GNDaux
13	Reserved	Not connected		
14	GNDaux	Auxiliary ground	GND	

Table 2: Basic Control Connector

6.3 P102: Advanced Control Connector

Type: JST, B22B-PHDSS (LF)(SN)				
Pin	Function	Description	Type	Reference
1	AmpReady	Amplifier ready indicator	Status output, open collector, active low	GNDaux
2	GNDaux	Auxiliary ground	GND	
3	TempWarning	Temperature warning indicator	Status output, open collector, active low	GNDaux
4	Ilim1	Current limit indicator, channel 1	Status output, open collector, active low	GNDaux
5	Temp	Module temperature monitor	Analog output	GNDaux
6	Ilim2	Current limit indicator, channel 2	Status output, open collector, active low	GNDaux
7	Reserved	Not connected		
8	Reserved	Not connected		
9	Reserved	Not connected		
10	GNDaux	Auxiliary ground	GND	
11	DVDD	Control auxiliary supply	Power output	GNDaux
12	Reserved	Not connected		
13	DVDDstby	Control auxiliary standby supply	Power output	GNDaux
14	Reserved	Not connected		
15	ON	Module on indicator	Status output, open collector, active low	GNDaux
16	Reserved	Not connected		
17	STBY	Module standby indicator	Status output, open collector, active low	GNDaux
18	Trigger	Turn on module	Control input, active high	GNDaux
19	GNDaux	Auxiliary ground	GND	
20	SignalSense shield	Signal Sense shield	Analog audio input shield	Resistor to GNDaux
21	SignalSense+	Non-inverting signal sense input	Analog audio input	GNDaux
22	SignalSense-	Inverting signal sense input	Analog audio input	GNDaux

Table 3: Advanced Control Connector

6.4 P105: Audio Input Connector

Type: JST, B6B-PH-K-S (LF)(SN)				
Pin	Function	Description	Type	Reference
1	In1 shield	Signal shield, channel 1	Analog audio input shield	Resistor to GND
2	In1+	Non-inverting input signal, channel 1	Analog audio input	GND
3	In1-	Inverting input signal, channel 1	Analog audio input	GND
4	In2 shield	Signal shield, channel 2	Analog audio input shield	Resistor to GND
5	In2+	Non-inverting input signal, channel 2	Analog audio input	GND
6	In2-	Inverting input signal, channel 2	Analog audio input	GND

Table 4: Audio Input Connector

6.5 P107: Channel 1 Loudspeaker Output Connector

Type: JST, B4P-VH (LF)(SN)			
Pin	Function	Description	Type
1	Out1+	Non-inverting output signal	Audio power output
2	Out1+	Non-inverting output signal	Audio power output
3	Out1-	Inverting output signal	Audio power output
4	Out1-	Inverting output signal	Audio power output

Table 5: Channel 1 Loudspeaker Output Connector

6.6 P108: Channel 2 Loudspeaker Output Connector

Type: JST, B4P-VH (LF)(SN)			
Pin	Function	Description	Type
1	Out2+	Non-inverting output signal	Audio power output
2	Out2+	Non-inverting output signal	Audio power output
3	Out2-	Inverting output signal	Audio power output
4	Out2-	Inverting output signal	Audio power output

Table 6: Channel 2 Loudspeaker Output Connector

Note: P108 is not mounted in 1200AS1

6.7 P106: Voltage and Current Monitor Output Connector

Type: JST, B8B-PH-K-S (LF)(SN)				
Pin	Function	Description	Type	Reference
1	Vmon1 GNDS	Ground sense, Voltage monitor channel 1	Analog output	Resistor to GNDaux
2	Vmon1	Voltage monitor, channel 1	Analog output	GNDaux
3	Imon1 GNDS	Ground sense, Current monitor channel 1	Analog output	Resistor to GNDaux
4	Imon1	Current monitor, channel 1	Analog output	GNDaux
5	Vmon2 GNDS	Ground sense, Voltage monitor channel 2	Analog output	Resistor to GNDaux
6	Vmon2	Voltage monitor, channel 2	Analog output	GNDaux
7	Imon2 GNDS	Ground sense, Current monitor channel 2	Analog output	Resistor to GNDaux
8	Imon2	Current monitor, channel 2	Analog output	GNDaux

6.8 P104: Hanger Rail Supply Connector

Type: JST, B03P-NV (LF)(SN)				
Pin	Function	Description	Type	Reference
1	VD	Positive amplifier DC rail supply	Power output	GND
2	GND	Ground	GND	
3	VS	Negative amplifier DC rail supply	Power output	GND

Table 7: Hanger Rail Supply Connector

Note: As specified in Section 11.7, a fast acting 5 A fuse MUST be included in the supply line on an optional amplifier module connected to the Hanger Rail Supply connector.

6.9 P103: Hanger Control Connector

Type: JST, B8B-PHDSS (LF)(SN)				
Pin	Function	Description	Type	Reference
1	GNDaux	Auxiliary ground	GND	
2	Reserved	Not connected		
3	VDD	Positive hanger auxiliary supply	Power output	GNDaux
4	Reserved	Not connected		
5	VSS	Negative hanger auxiliary supply	Power output	GNDaux
6	Reserved	Not connected		
7	Vdrive	Drive hanger supply	Power output	VS
8	Reserved	Not connected		

Table 8: Hanger Supply Low Voltage Connector

Note: The Hanger Control connector must be used with ICEpower hanger modules only. Use of this connection for any other purpose is against the ICEpower warranty policy.

7 Absolute Maximum Rating

Symbol	Parameter	Min	Max	Units
V_{ac}	Mains input voltage (safety test)	85 ¹	264 ¹	V _{RMS}
f_{mains}	Mains frequency	45	65	Hz
V_{audio}	Audio inputs voltage relative to GND (DC+AC)	-8	8	V
$V_{control}$	Control inputs voltage	GND - 0.7	25	V
V_{status}	Status output external pull up voltage	GND - 0.7	DVDD + 0.7	V
I_{status}	Status output sink current	0	20	mA

Table 9: Absolut maximum ratings

¹The maximum operating/usage mains voltage is 240Vac and the minimum operating/usage mains voltage is 100Vac.

8 Electrical Specifications

Unless otherwise specified:

- Specifications are common to ICEpower1200AS1 and ICEpower1200AS2.
- $T_a = 25\text{ °C}$, $f = 1\text{ kHz}$, $R_L = 4\text{ Ohm}$, 230 V / 50 Hz mains, AES17 measurement filter and Audio Precision AUX-0025 filter,
- Module mounted on a heatsink with $R_{th} = 0.8\text{ K/W}$ (e.g. Fisher Elektronik SK198 - 100mm or Aavid Thermalloy OS489 - 100mm)

8.1 Audio

Symbol	Parameter	Condition	Min	Typ	Max	Unit
P_o	Output power one channel driven	$f_{in} = 1\text{ kHz}$, THD+N $\leq 1\%$, $R_L = 4\text{ Ohm}$ 230 V _{ac} / 50 Hz 120 V _{ac} / 60 Hz 100 V _{ac} / 50 Hz		1250 1250 970		W
P_o	Output power one channel driven	$f_{in} = 1\text{ kHz}$, THD+N $\leq 10\%$, $R_L = 4\text{ Ohm}$ 230 V _{ac} / 50 Hz 120 V _{ac} / 60 Hz		1550 1420		W
P_o	Output power one channel driven	$f_{in} = 1\text{ kHz}$, THD+N = 1%, $R_L = 8\text{ Ohm}$ 230 V _{ac} / 50 Hz 120 V _{ac} / 60 Hz		620 620		W
t_{pmax}	Duration of power burst at full power, one channel driven	$f_{in} = 1\text{ kHz}$, $P_o = 1200\text{ W} / 4\text{ Ohm}$ 230 V _{ac} / 50 Hz 120 V _{ac} / 60 Hz		90 15		sec
P_{o-con}	Continuous output power without thermal shutdown, one channel driven	$f_{in} = 1\text{ kHz}$, THD+N $\leq 1\%$, $R_L = 4\text{ Ohm}$ 230 V _{ac} / 50 Hz 120 V _{ac} / 60 Hz		290 280		W
P_o	1200AS2 Output power per channel, both channels driven	$f_{in} = 1\text{ kHz}$, THD+N $\leq 1\%$, $R_L = 4\text{ Ohm}$ 230 V _{ac} / 50 Hz 120 V _{ac} / 60 Hz 100 V _{ac} / 50 Hz		700 670 460		W
P_o	1200AS2 Output power per channel, both channels driven	$f_{in} = 1\text{ kHz}$, THD+N $\leq 1\%$, $R_L = 8\text{ Ohm}$ 230 V _{ac} / 50 Hz 120 V _{ac} / 60 Hz		620 610		W

Symbol	Parameter	Condition	Min	Typ	Max	Unit
t_{Pmax}	1200AS2 Duration of power burst at full power, both channels driven	$f_{in} = 1 \text{ kHz}$, $P_o = 600 \text{ W / ch}$, $R_L = 4 \text{ Ohm}$ 230 Vac / 50 Hz 120 Vac / 60 Hz		90 15		sec
P_{o-con}	1200AS2 Continuous combined output power without thermal shutdown, both channels driven (Note)	$f_{in} = 1 \text{ kHz}$, $THD+N \leq 1 \%$, $R_L = 4 \text{ Ohm}$ 230 Vac / 50 Hz 120 Vac / 60 Hz		280 270		W
V_{o-max}	Maximum output voltage			100		V_p
I_{o-max}	Maximum output current	(Output current limited)		38		A_p
THD+N	Total harmonic distortion + noise, one channel driven	$f_{in} = 1 \text{ kHz}$, $P_o = 10 \text{ W / 4 Ohm}$		0.003		%
N	Output noise	20 Hz – 20 kHz, un-weighted 20 Hz – 20 kHz, A-weighted		45 30		μV
DNR	Dynamic range	20 Hz – 20 kHz, un-weighted 20 Hz – 20 kHz, A-weighted		123 127		dB
IMD ₃	3 rd order intermodulation, one channel driven (Figure 8)	18 kHz + 19 kHz, each -10dB relative to 1200 W / 4 Ohm		-97		dB
	Idle tones	$V_{in} = 0 \text{ V}$, 0 dB = 1200 W / 4 Ohm		-150		dB
	1200AS2 Channel separation	$f_{in} = 1 \text{ kHz}$, $P_o = 12 \text{ W / 4 Ohm}$,		-110		dB
V_{in}	Input sensitivity	$f_{in} = 1 \text{ kHz}$, $P_o = 1200 \text{ W / 4 Ohm}$		5.0		V_p
A_v	Voltage gain	$f_{in} = 1 \text{ kHz}$		25.8		dB
f	Frequency response	$f_{in} = 20 \text{ Hz} - 20 \text{ kHz}$, $R_L = 4 - 8 \text{ Ohm}$		+0/-0.5		dB
f_U	Upper bandwidth (-3dB)	$R_L = \text{all loads}$, $P_o = 10 \text{ W}$, no measurement filters		50		kHz
f_L	Lower bandwidth (-3dB)	$R_L = \text{all loads}$, $P_o = 10 \text{ W}$, no measurement filters		3		Hz
$f_{U-power}$	Upper bandwidth at nominal power	$R_L = 4 \text{ Ohm}$, $P_o = 1200 \text{ W / 4 Ohm}$, no measurement filters		25		kHz
$f_{L-power}$	Lower bandwidth at nominal power	$R_L = 4 \text{ Ohm}$, $P_o = 1200 \text{ W / 4 Ohm}$, no measurement filters		20		Hz
Z_o	Output impedance	$f_{in} = 1 \text{ kHz}$		6		mOhm
R_{load}	Load impedance		2.7			Ohm
C_{load}	Capacitive load				400	nF
$Z_{in-signal}$	Input impedance signal lines	Fully balanced input configuration, Non-inverting input Inverting input		38 38		kOhm
Z_{in-GND}	Audio input shield to GND impedance			22		Ohm

Symbol	Parameter	Condition	Min	Typ	Max	Unit
V_{clamp}	Audio input clamp voltage			7		V
$V_{\text{in_CMR}}$	Input common mode range		-7		7	V
f_{PWM}	Amplifier power stage switching frequency	Idle, no audio input		500		kHz

Table 10: Audio performance

Note: The continuous combined output power is the sum of the power of the driven channels. The available output power can be distributed evenly or asymmetrically across the channels.

Asymmetrical loading of the channels can be caused by e.g. differences in signal level or program material in bass and treble in an active speaker or due to differences in speaker impedances.

8.2 Speaker Output Voltage and Current Monitors

Symbol	Parameter	Conditions	Min	Typ	Max	Units
V_{Vmon}	Vmon output voltage range		-12		12	V
A_{Vmon}	Voltage monitor gain, speaker output to Vmon output			0.12		-
f_{Vmon}	Voltage monitor frequency response	$f_{\text{in}} = 20 \text{ Hz} - 20 \text{ kHz}$		+/-0.1		dB
Φ_{Vmon}	Voltage monitor phase response	$f_{\text{in}} = 20 \text{ Hz} - 20 \text{ kHz}$		+0/-15		deg
V_{Imon}	Imon output voltage range		-12		12	V
R_{Imon}	Current monitor equivalent sense resistor			0.33		Ohm
f_{Imon}	Current monitor frequency response	$f_{\text{in}} = 20 \text{ Hz} - 20 \text{ kHz}$		+/-0.1		dB
Φ_{Imon}	Current monitor phase response	$f_{\text{in}} = 20 \text{ Hz} - 20 \text{ kHz}$		+5/-10		deg
Z_{out}	Monitor output impedance			100		Ohm
$Z_{\text{out-GNDS}}$	Monitor output impedance, ground sense wire			100		Ohm

8.3 Control and Status

Symbol	Parameter	Conditions	Min	Typ	Max	Units
V_{control}	Control input voltage range		0		DVDD	V
$V_{\text{control_low}}$	Control input low signal				0.8	V
$V_{\text{control_high}}$	Control input high signal		2.5			V
V_{Trigger}	Trigger input voltage range		0		12	V
Z_{control}	Control input impedance	Internal pull down		50		kOhm
V_{status}	Status output voltage range	Open collector, external pull up	0		DVDD	V
$V_{\text{status_low}}$	Status output low	$I_{\text{out}} = 1 \text{ mA}$		0.5		V
I_{status}	Status output sink current		0		20	mA
Z_{status}	Status output series impedance			240		Ohm
$V_{\text{SignalSense-Thres}}$	Signal sense trigger threshold			3		mV_{RMS}
$Z_{\text{SignalSense-in}}$	Signal sense input impedance	Fully balanced		100		kOhm
$Z_{\text{SignalSense-GND}}$	Signal sense shield to GNDaux impedance			22		Ohm

Symbol	Parameter	Conditions	Min	Typ	Max	Units
f _{SignalSense-L}	Signal sense lower bandwidth	-3 dB		20		Hz
f _{SignalSense-U}	Signal sense upper bandwidth	-3 dB		2.4		kHz
T _{Amp-OT-warning}	Amplifier temperature warning			110		°C
T _{PSU-OT-warning}	PSU temperature warning			85		°C
T _{Amp-OT-clip}	Amplifier over temperature clip			120		°C
T _{PSU-OT-clip}	PSU over temperature clip			90		°C
T _{Amp-OT-limit}	Amplifier over temperature limit			125		°C
T _{PSU-OT-limit}	PSU over temperature limit			95		°C
T _{Amp-OT-reset}	Amplifier over temperature reset			100		°C
T _{PSU-OT-reset}	PSU over temperature reset			87		°C
V _{Temp}	Temperature monitor output range		0		3.0	V
Temp	Temp range		50		120	°C

Table 11: Control and Status specifications

8.4 Timing

For detailed description of the below listed timing values, please consult Section 11 of this datasheet.

Symbol	Parameter	Conditions	Min	Typ	Max	Units
t _{Mains-Audio-set}	Mains input – audio output delay	P _o = 1200 W / 4 Ohm		2.4		s
t _{Mains-Audio-hold}	Mains input – audio output hold time	1/8 P _o into 4 Ohm, no aux load		230		ms
t _{Mains-Aux-set}	Mains input – aux supply delay	1/8 P _o into 4 Ohm, no aux load		1.2		s
t _{Mains-Aux-hold}	Mains input – aux supply hold time	1/8 P _o into 4 Ohm, no aux load		2		s
t _{Stby-Audio-set}	Standby-mode set delay			140		ms
t _{Stby-Audio-release}	Standby-mode release delay	P _o = 1200 W / 4 Ohm		1.5		s
t _{Stby-AVDD-AVSS-hold}	Standby-mode AVDD/AVSS hold time	no aux load		18.5		s
t _{Stby-AVDD-AVSS-release}	Standby-mode AVDD/AVSS release time	no aux load		740		ms
t _{Stby-Idvdd-delay}	Standby-mode – I _{DVDD} delay			500		ms
t _{AmpDis-Audio-set}	AmpDisable set delay			100		ms
t _{AmpDis-Audio-release}	AmpDisable release delay			500		ms
t _{Aux-OC-detect}	Aux OC detect delay			4		ms
t _{Aux-OC-recovery}	Aux OC recovery			6.5		s
t _{Amp-Protect-recovery}	Amplifier Protect recovery			9.5		s
t _{Amp-OT-recovery}	Amplifier OT recovery			500		ms
t _{Clip-out}	Clip indication pulse duration		1			ms
t _{Ilim-pulse}	Current limit pulse width		10			ms
t _{STBY-release}	STBY output release delay	no aux load		0.7		s
t _{On-release}	On output release delay	no aux load		11		s
t _{AmpReady-release}	AmpReady output release delay			90		ms
t _{AmpReady-set}	AmpReady output set delay			480		ms
t _{SignalSense}	SignalSense timeout			13		min

Table 12: Timing specifications

8.5 Power Supply

Symbol	Parameter	Condition	Min	Typ	Max	Unit
V _{DVDD}	Control aux supply, output voltage	I _{DVDD} < 1.0 A	4.9	5.1	5.3	V
I _{DVDD}	Control aux supply, output current	Normal operation (Output current limited)			1	A
I _{DVDDstby}	Control aux supply, output current	Standby-mode			40	mA
C _{DVDD}	DVDD external decoupling capacitor				1000	uF
V _{AVDD}	Positive analog auxiliary supply, output voltage	I _{AVDD} < 500mA	14	15	17	V
I _{AVDD}	Positive analog auxiliary supply, output current (Note 3)	(Output current limited)			500	mA
C _{AVDD}	AVDD external decoupling capacitor				470	uF
V _{AVSS}	Negative analog auxiliary supply, output voltage	I _{AVSS} < -500mA	-17	-15	-14	V
I _{AVSS}	Negative analog auxiliary supply, output current (Note 3)	(Output current limited)			-500	mA
C _{AVSS}	AVSS external decoupling capacitor				470	uF
V _{VD}	Positive hanger supply, output voltage		55	63	75	V
I _{VD}	Positive hanger supply, output current (Note 1)	Output NOT over-current protected			5	A
C _{VD}	VD external decoupling capacitor				2000	uF
V _{VS}	Negative hanger supply, output voltage		-75	-63	-55	V
I _{VS}	Negative hanger supply, output current (Note 1)	Output NOT over-current protected			-5	A
C _{VS}	VS external decoupling capacitor				2000	uF
V _{VDD}	Positive hanger analog supply, output voltage	I _{VDD} < 100mA		12		V
I _{VDD}	Positive hanger analog supply, output current (Note 2) (Note 3)	Output not over-current protected			100	mA
V _{VSS}	Negative hanger analog supply, output voltage	I _{VSS} < -100mA		-12		V
I _{VSS}	Negative hanger analog supply, output current (Note 2) (Note 3)	Output not over-current protected			-100	mA
V _{Vdrive}	Hanger drive supply, output voltage			V _{VS} + 12		V
I _{Vdrive}	Hanger drive supply, output current (Note 2) (Note 3)	Output not over-current protected			200	mA

Symbol	Parameter	Condition	Min	Typ	Max	Unit
P _{idle}	Module idle consumption, amp enabled	1200AS1, P _{aux} = 0 W 1200AS2, P _{aux} = 0 W		27 35		W
P _{amp_disabled}	Module idle consumption, amp disabled	1200AS1, P _{aux} = 0 W 1200AS2, P _{aux} = 0 W		19 19		W
P _{standby}	Module standby consumption	230 V _{ac} / 50 Hz, I _{DVDD} = 0 mA 120 V _{ac} / 60 Hz, I _{DVDD} = 0 mA		250 140		mW
P _{mains}	Mains power	P _{out_audio} = 150 W, +/-15V outputs loaded with 500 mA each. 5V loaded with 1A. T _{operating} = 60°C with fan 90 – 264 Vac / 50 – 60 Hz		250		W
P _{mains}	Mains power	P _{out_audio} = 150 W, +/-15V outputs loaded with 500 mA each. 5V loaded with 1A. T _{operating} = 40°C without fan 90 – 264 Vac / 50 – 60 Hz		250		W
η	Module power efficiency	P _{aux} = 0 W, 1200AS1, P _{out} = 1200 W 1200AS2, P _{out} = 2 x 600 W		80 79		%
PF	Power factor	P _{out} = 1200 W		0.92		

Table 13: Power specifications

Note 1: As specified in Section 11.7, a fast acting 5 A fuse MUST be included in the supply line on an optional amplifier module connected to the Hanger Rail Supply connector. Failure to comply with this requirement is against the ICEpower warranty policy.

Note 2: Hanger analog and drive supplies are intended for ICEpower hanger modules only. Use of these outputs for any other purpose is against the ICEpower warranty policy.

Note 3: The sum of the power consumption on the AVDD, AVSS, VDD and VSS supply outputs must not exceed 15 W.

9 Mechanical Specification

9.1 Dimensions

Symbol	Parameter	Condition	Min	Typ	Max	Unit
L	Module length			300		mm
W	Module width			100		mm
H	Module height				63	mm
Mass	Weight	1200AS1 1200AS2		1150 1250		g
H _{Base}	Base plate thickness		2.85		3.15	mm
H _{M3}	Mounting hole depth	M3 threads on module base plate			5.0	mm
T	Mounting torque	M3 threads on module base plate			0.5	Nm

Table 14: Mechanical dimensions

9.2 Mounting Holes

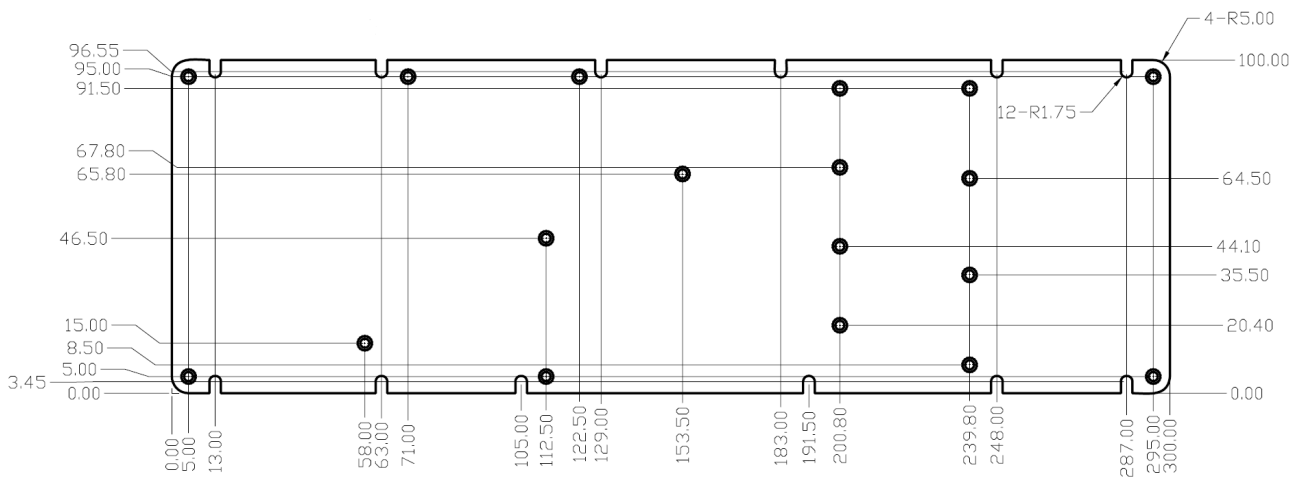

Figure 3: ICEpower1200AS baseplate mechanical dimensions in mm seen from top side

Environmental Specifications

Symbol	Parameter	Conditions	Min	Typ	Max	Units
T _{operating}	Ambient temperature, operating – active cooled with fan ^(Note 4)	End-customer use cases	0		60	°C
T _{operating}	Ambient temperature, operating – passive cooled, no fan ^(Note 5)	End-customer use cases	0		40	°C
T _{storage}	Ambient temperature, storage	End-customer use cases	-40		70	°C
T _{shelf}	Ambient temperature, shelf	Storage before goods sold to end-customer	0		50	°C
RH	Relative humidity	Non-condensing Operating and storage			85	%
	Altitude, operating				2000	m

Table 15: Environment specifications

Note 4: For safety test at 60°C ambient with fan and with the module mounted vertical on an aluminum plate/heatsink and maximum AUX current draw, the maximum continuous output power without thermal shutdown is 150 W (1/8 of rated power). With larger heatsink the continuous output power without thermal shutdown might be increased.

Note 5: For safety test at 40°C ambient without fan and with the module mounted vertical on an aluminum plate/heatsink and maximum AUX current draw, the maximum continuous output power without thermal shutdown is 150 W (1/8 of rated power). With larger heatsink the continuous output power without thermal shutdown might be increased.

9.3 Mechanical and Environmental Tests

ICEpower1200AS has undergone extensive environmental testing including Highly Accelerated Life Test (HALT).

Test	Acceleration	Amount
Random vibration	2.1 g _{rms} , random profile composed of 5 frequencies in the range 5 Hz to 275 Hz	3 perpendicular directions 3 x 20 min. + 3 x 10 min. + 3 x 10 min.
Shock	40 g / 26 ms to 70 g / 12 ms in steps of 10 g	6 directions, 3 shocks per direction

Table 16: Mechanical tests

To ensure overall end-product robustness, ICEpower recommends vibration test of the final product including the ICEpower1200AS module. Excess vibration caused by e.g. insufficiently damped resonances in a mechanical chassis or extensive exposure to high sound pressure level audio from a speaker unit can damage the product.

10 Typical Performance Characteristics

Unless otherwise specified: Test frequency 1 kHz, $T_a = 25\text{ }^\circ\text{C}$, 230 V / 50 Hz mains, module mounted on a heatsink with $R_{th} = 0.8\text{ K/W}$ (e.g. Fisher Elektronik SK198 – 100 mm or Aavid Thermalloy 0S489 – 100 mm). Audio Precision AUX-0025 and AES17 20 kHz filter.

10.1 Frequency Response

Measurement bandwidth: 0 – 500 kHz. $P_o = 10\text{ W} / 4\text{ Ohm}$

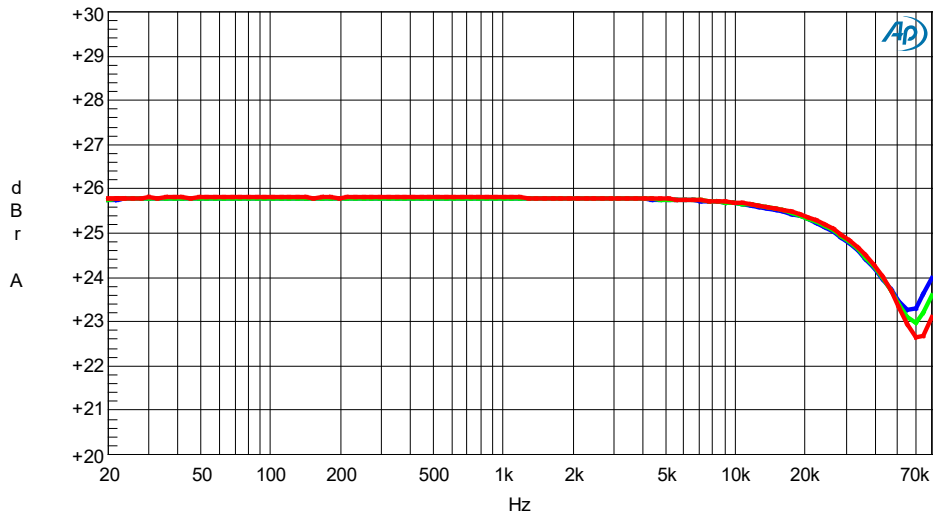

Figure 4: Amplitude vs frequency @ $R_L = 4\text{ Ohm}$ (blue), $R_L = 8\text{ Ohm}$ (green) and open load (red)

10.2 Total Harmonic Distortion

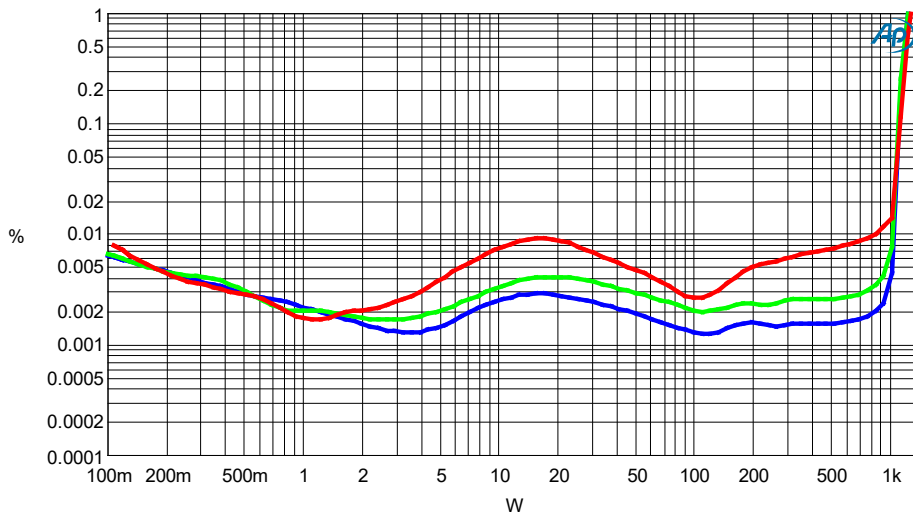

Figure 5: THD+N vs power @ 100 Hz (blue), 1 kHz (green), 6.66 kHz (red), $R_L = 4 \text{ Ohm}$

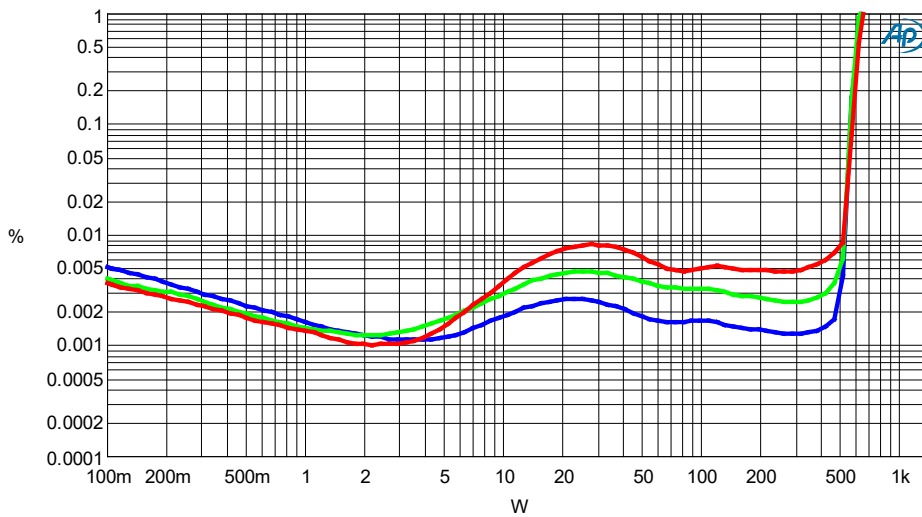

Figure 6: THD+N vs power @ 100 Hz (blue), 1 kHz (green), 6.66 kHz (red), $R_L = 8 \text{ Ohm}$

10.3 Idle Noise

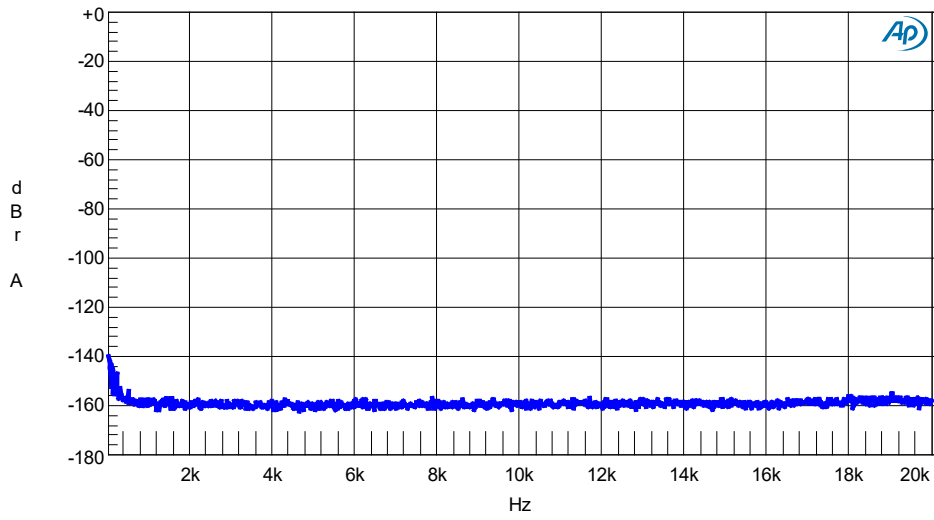

Figure 7: Idle noise spectrum, 0 – 20 kHz @ 0dB = 1200 W/4 Ohm

10.4 Intermodulation

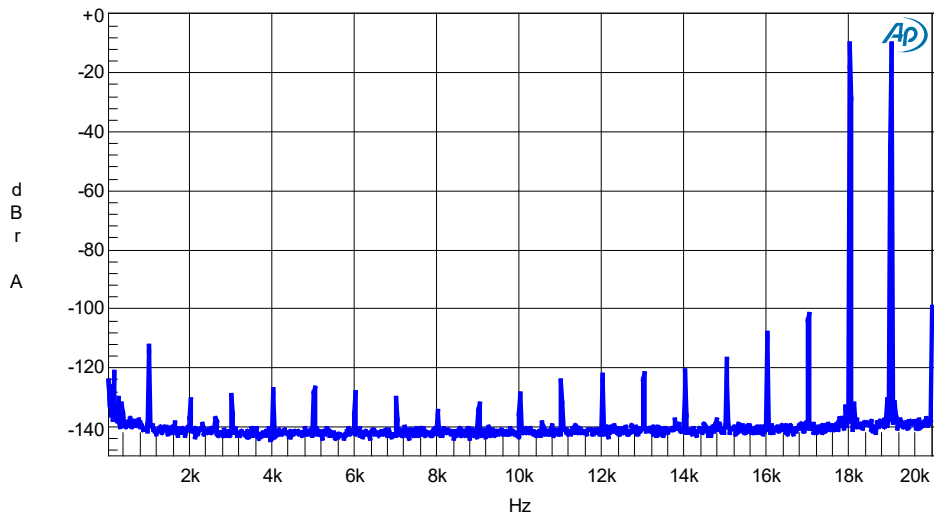

Figure 8: Dual tone intermodulation spectrum, 0 – 20 kHz @ 0dB = 1200 W/4 Ohm

10.5 Channel Separation

ICEpower1200AS2

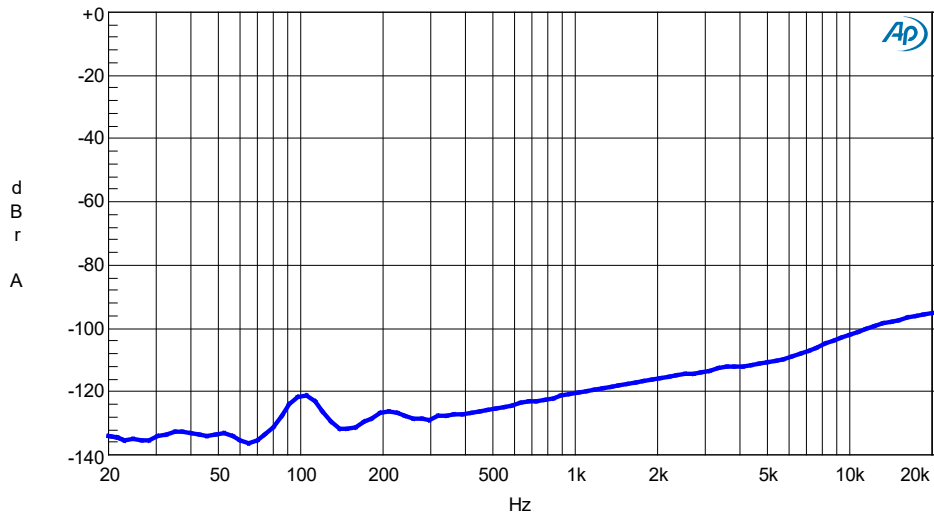

Figure 9: Channel separation 1200AS2, 20 Hz – 20 kHz @ $P_o = 12\text{ W} / 4\text{ Ohm}$

10.6 Output Impedance

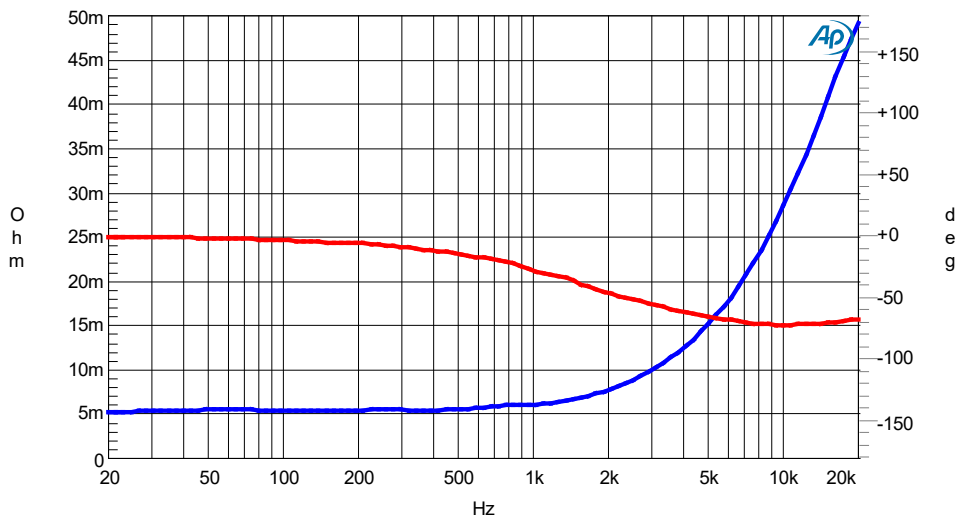

Figure 10: Output impedance vs frequency 20 Hz – 20 kHz (blue), phase (red)

Damping Factor

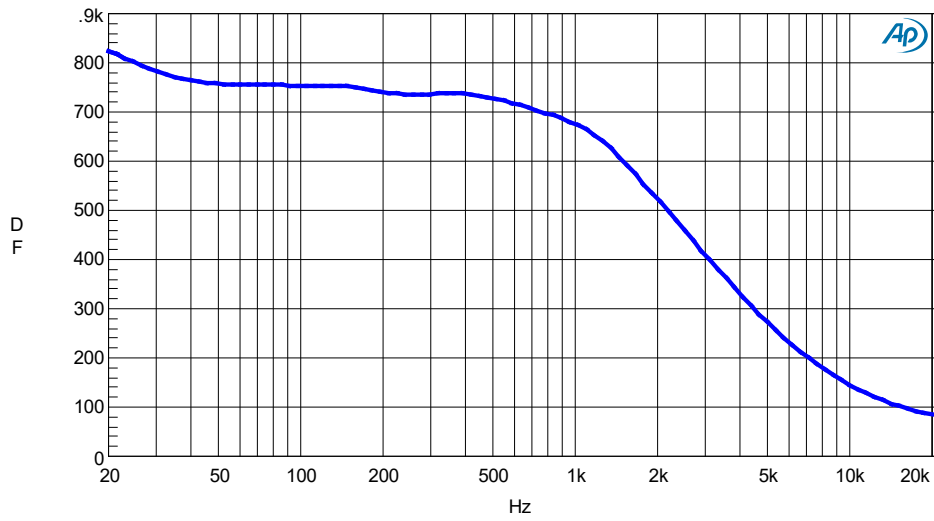

Figure 11: Damping factor vs frequency 20 Hz – 20 kHz, 4 Ohm (blue)

10.7 Output Power vs Mains

ICEpower1200AS

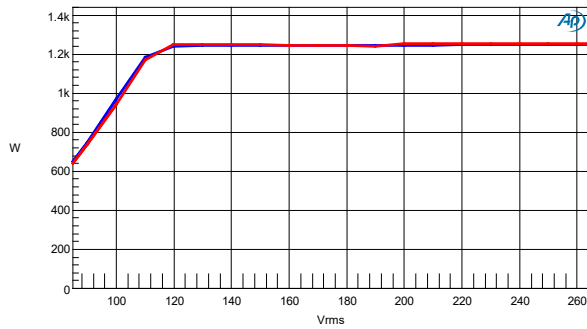

Figure 12: Output power vs mains voltage, one channel driven, mains freq. 50 Hz (blue), 60 Hz (red)

ICEpower1200AS2

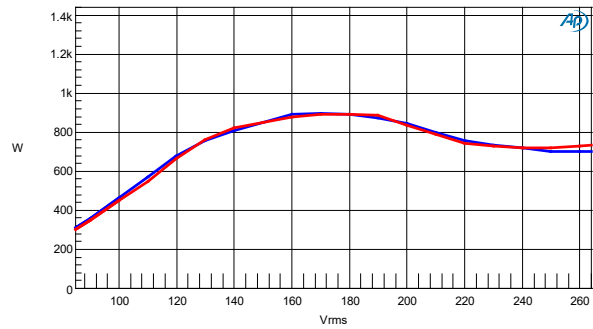

Figure 13: Output power per channel vs mains voltage, both channels driven, mains freq. 50 Hz (blue), 60 Hz (red)

10.8 Power Efficiency

ICEpower1200AS

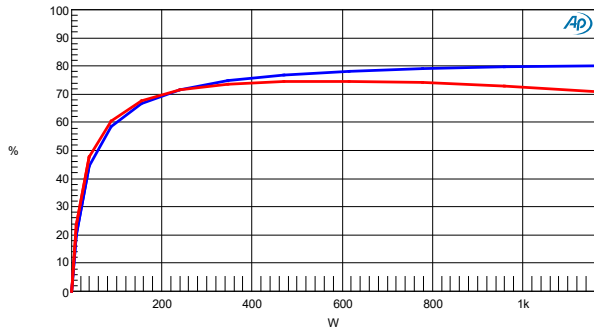

Figure 14: Power efficiency vs. output power, one channel driven, 230 V / 50 Hz (blue), 120 V / 60 Hz (red)

ICEpower1200AS2

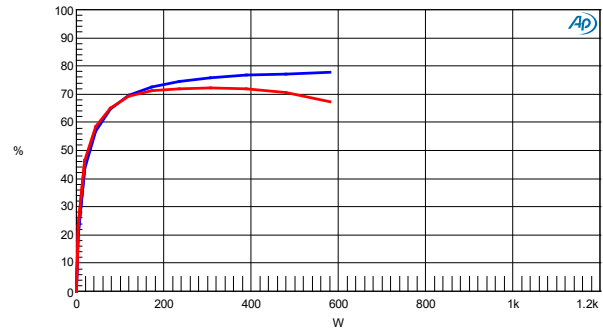

Figure 15: Power efficiency vs. output power per channel, both channels driven, 230 V / 50 Hz (blue), 120 V / 60 Hz (red)

10.9 Dissipated Power

ICEpower1200AS

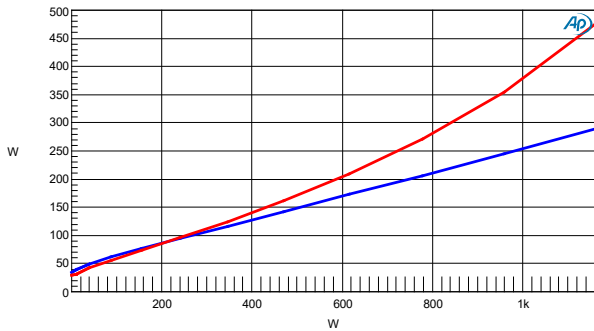

Figure 16: Dissipated power vs. output power, one channel driven, 230 V / 50 Hz (blue), 120 V / 60 Hz (red)

ICEpower1200AS2

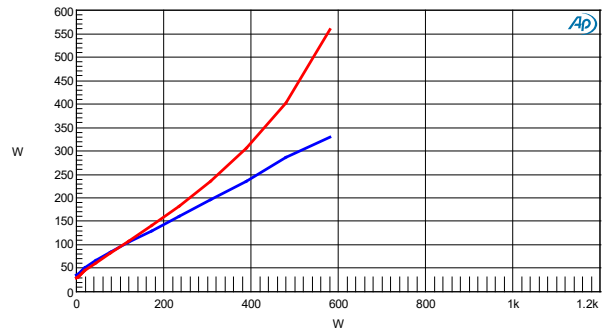

Figure 17: Dissipated power vs. output power per channel, both channels driven, 230 V / 50 Hz (blue), 120 V / 60 Hz (red)

11 Functional Description

ICEpower1200AS will start operating when power is applied to the module and therefore no special control is needed for simple applications. For more advanced applications, a wide set of control, status and monitoring inputs and outputs are available all through connectors following the ICEpower Standard Interface definition. Additionally, auxiliary power supply outputs are provided for signal and control front-ends as well as power for an optional hanger amplifier module.

Following ICEpower's "Music at All Times" philosophy, the module will operate under all conditions except for potentially destructive situations. At power-up, the 1200AS module performs comprehensive checks to verify operation conditions and to check for errors. If an error is detected, the module will try to reboot after a short delay. As part of the effort to keep music playing, the module monitors numerous internal parameters during operation and reacts proactively if required.

In three distinct situations, the module will initiate a progressive clipping of the audio signal to limit the loading of the module. These situations are:

- Temperature conditions close to thermal shutdown
- Power supply overload
- Excess super-sonic audio content

Should the progressive limitation of the output power be insufficient to maintain safe operation or if a potentially destructive error should occur, the 1200AS module will shut down and automatically restart after the overload situation is removed.

In the following subsections, a description is given for all 1200AS features organized per the connector in which the corresponding input or output is located.

11.1 Audio Input

The audio inputs of the 1200AS are high impedance fully balanced inputs including a non-inverting and inverting signal input and a signal ground.

The audio inputs can be used in both a semi-balanced input configuration and in a fully balanced configuration. In semi-balanced configuration, it is recommended to connect the non-inverting input to a single ended signal source and use the inverting input as ground sense on the signal source ground reference. In both semi-balanced and in fully balanced configuration, the signal ground should be connected to ground on the front-end PCB.

To prevent ground loop related noise and hum problems, the signal ground is fitted with low value series resistors on the module i.e. the signal ground wire must not carry any additional current. The recommended connection to the audio input is shown on Figure 27 in Section 12.

To get best possible suppression of noise and mains related hum in the end-product and to utilize the module common mode rejection, proper attention must be put into signal source output impedance.

The two audio signal inputs share the same connector on the 1200AS modules. In the one channel version 1200AS1, the channel 2 inputs are left unconnected.

11.2 Speaker Outputs

The speaker output of the 1200AS is a balanced output with two active signal lines capable of driving complex speaker loads. As the speaker outputs are already in a balanced configuration, bridging of two channels is not possible.

The speaker outputs are fully overload and short circuit protected. In case of an overload or short circuit event, the module will limit the output power and eventually shut down and resume operation when the overload or short circuit has been removed.

Due to the balanced operation, it is not possible to connect one of the outputs to ground. The module is protected against such an event.

On the 1200AS1, only channel 1 speaker output is mounted.

11.3 AC Mains Input

ICEpower1200AS has a universal mains input operating on all common mains supplies. No switching between low and high mains is required. Additionally, the power supply includes Power Factor Correction complying with international standards.

When power is applied to the 1200AS, the module will after a short initialization read the control inputs and start operating accordingly. If the module controls are left unconnected, the module will start normal operation without further action.

The power up and power down timing is shown in Figure 18 and specific timing values are available in Section 8.4.

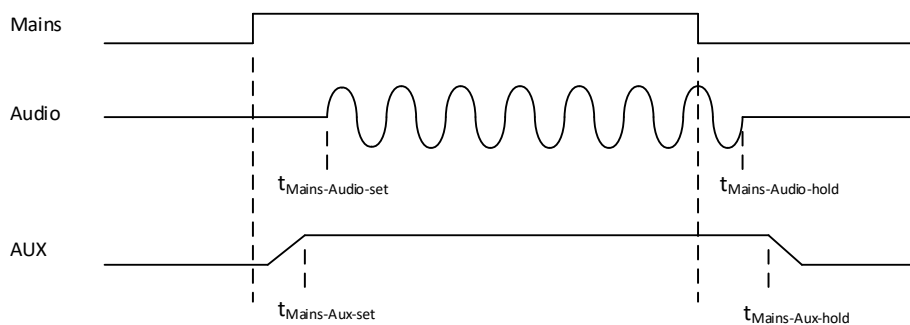

Figure 18: Power up timing

The 1200AS is fitted with a fuse on the mains input. In case of a burned fuse, the module is defective and must be replaced.

11.4 Basic Control and Status

The Basic Control and Status connector includes auxiliary power supply outputs for e.g. a signal front-end PCB and the following features:

- Standby input
- AmpDisable input
- Clip1 and Clip2 output
- Protect output

The recommended connection to the control input and status outputs are shown on Figure 30 and Figure 31 in Section 12.

11.4.1 Standby Input

The Standby input brings the 1200AS in standby-mode when pulled high. An internal pull down ensures normal operation mode if the Standby input is left unconnected.

In standby-mode, the amplifier section of the 1200AS will shut down leaving only the power supply operating in a low power mode. To reduce power consumption in the overall system including an external signal front end and a hanger amplifier module, all auxiliary supply outputs except for DVDD and DVDDstby are shut off while the control supply DVDD is kept running in a low power mode. In this low power mode, DVDD and DVDDstby can deliver a reduced amount of current for e.g. a front-end system microcontroller.

Timing of the Standby input is shown in Figure 19 and specific timing values are available in Section 8.4. Additional information on the Standby input is given in Figure 26 together with information on the Trigger and SignalSense inputs.

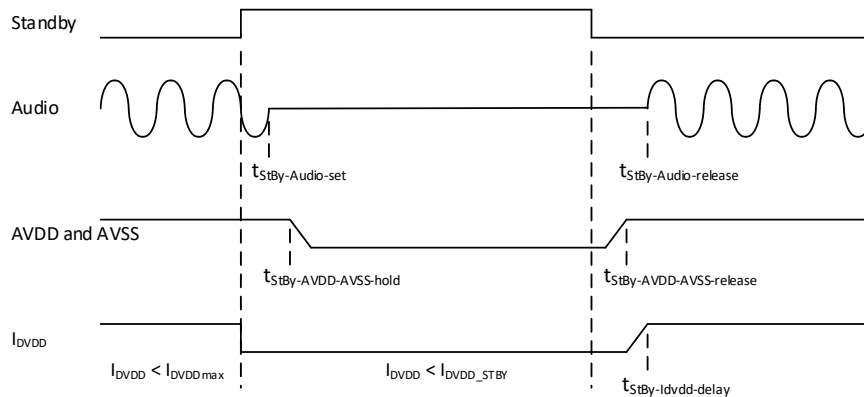

Figure 19: Standby timing on auxiliary supplies

Before bringing the 1200AS in Standby mode, it is important to reduce the current consumption on DVDD supply output to a value below the specified maximum Standby mode current.

11.4.2 AmpDisable Input

The AmpDisable input shuts down the 1200AS amplifier section when pulled high. An internal pull down ensures normal operation if the AmpDisable input is left unconnected. In AmpDisable mode, all power supplies are left running including all auxiliary supply outputs.

This feature can be used in e.g. applications where an analog front-end requires extended settling time or a DSP based systems need time to boot at power up before enabling the amplifier.

Timing of the AmpDisable input is shown in Figure 20 and specific timing values are available in Section 8.4.

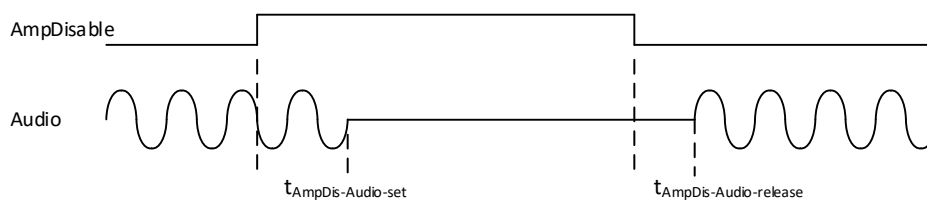

Figure 20: Standby and AmpDisable timing

Advanced pop and click reduction mechanisms are built into the 1200AS, leaving almost no audible artifacts when the Standby and AmpDisable inputs are used.

11.4.3 Clip1 and Clip2 Output

The Clip1 and Clip2 outputs are audio signal clipping indicators, one per channel. Clipping is indicated by a low on the Clip1 and Clip2 for channel 1 and 2 respectively. The clipping outputs stays low for the full duration of clipping in the audio signal, but to make it easier to detect very short clipping event and in cases where the clip signals are directly connected to a LED, the clipping signals on Clip1 and Clip2 have a minimum duration $t_{\text{Clip-out}}$.

The Clip1 and Clip2 outputs are open-collector outputs pulled high by external pull-up resistors. Interface schematics can be found in Section 12.4.

On the 1200AS1, the Clip2 output is left unconnected.

11.4.4 Protect Output

In case of potentially destructive overload situations, the 1200AS will shut down and resume operation after a short delay or after the overload-condition has been removed. These events are reported by a low level on the Protect output.

Events that will trigger the Protect output are:

- PSU is out of normal operating conditions
- Severe amplifier overcurrent conditions and short circuit in the amplifier section
- Over-temperature errors in the module
- Excess sub-sonic or super-sonic audio content
- Overload conditions on the analog auxiliary power supply outputs AVDD and AVSS
- Overload conditions on the control auxiliary power supply outputs, DVDD, DVDDstby,

In most cases, the 1200AS will resume operation shortly after the error condition has been removed. For the over-temperature case though, it is also required that the module temperature is brought below the temperature reset thresholds $T_{\text{Amp-OT-reset}}$ and $T_{\text{PSU-OT-reset}}$ again.

Additionally, it should be noted that an overload of the control auxiliary supply will cause a full system power down and power up and thus, the event will only be reported for as long as the power supply decoupling on the DVDD supply can hold up the voltage.

The Protect output is an open-collector output pulled high by an external pull up resistor. Interface schematics can be found in Section 12.4.

Timing of the protection events are shown in Figure 21 through Figure 23 and specific timing values are available in Section 8.4.

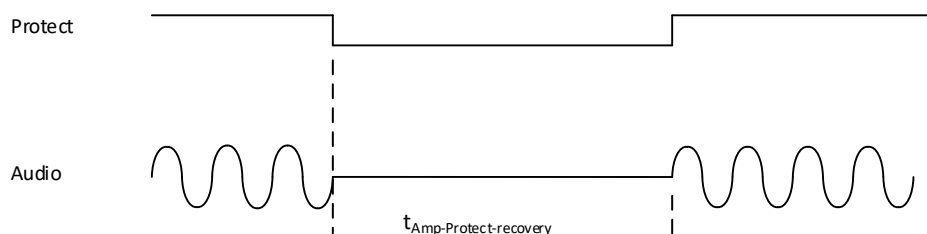

Figure 21: Amplifier Protect recovery

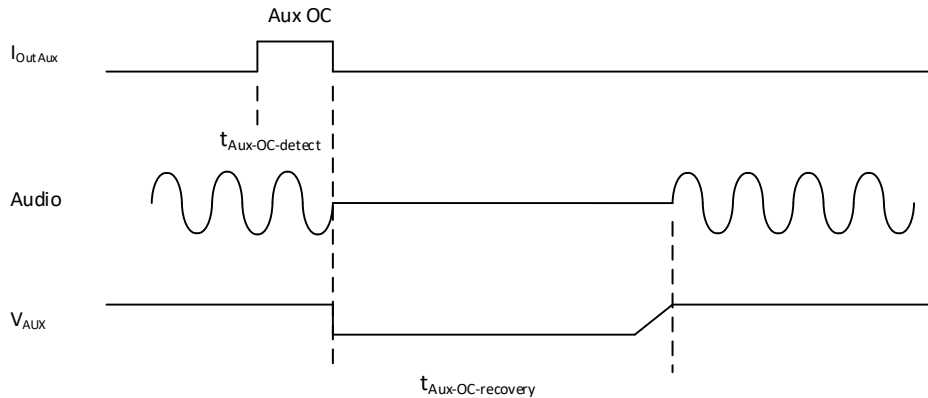

Figure 22: Auxiliary supply overcurrent timing

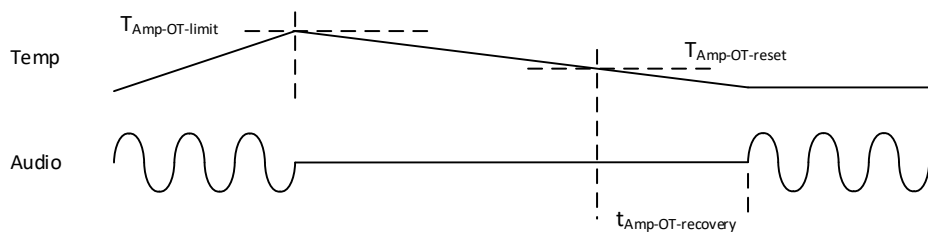

Figure 23: Temperature protection timing

11.4.5 DVDD and DVDDstby Power Supply Output

The DVDD and DVDDstby outputs are power supply outputs intended for control circuits on a front-end board e.g. microcontrollers and DSPs.

According to the ICEpower Standard Interface, circuits operating in Standby Mode must be supplied from DVDDstby output whereas the remaining frontend control circuits can be supplied from the DVDD output. The 1200AS has been fitted with a separate power supply for DVDD and DVDDstby capable of operating in both Standby Mode and in normal operation mode. Therefore, on the 1200AS module, the DVDDstby and DVDD are connected in parallel. To ensure best possible compatibility with other products following the ICEpower Standard Interface, it is recommended to connect control circuits as intended by the standard.

The DVDD and DVDDstby supply outputs are closely regulated and can be used without additional voltage regulator. It is recommended though to add extra supply line series feed impedances and decoupling capacitors on the connected PCB to attenuate the power supply voltage ripple. The series impedance can be either a low value resistor or a small inductor. The extra decoupling capacitance must not exceed the value specified in Table 13.

The DVDD and DVDDstby outputs are overload protected. An overload of these outputs will cause the full 1200AS module to turn off. When the overload condition has been removed the module will resume operation automatically after a short delay.

11.4.6 AVDD and AVSS Power Supply Output

The AVDD and AVSS outputs are positive and negative power supply outputs intended for analog circuits on a front-end board e.g. analog buffers and speaker crossover filters.

To ensure proper suppression of supply related noise and hum, it is important to have all supply related current draw through the GND connections in the power supply interface. The analog signal ground available in the audio interface connector must not carry any supply related current. For proposed grounding scheme details, please see Section 13.1

The AVDD and AVSS supply outputs are loosely regulated. They may require additional voltage regulators on a front-end board depending on the type of circuit supplied by these pins. It is therefore recommended to add extra supply line series feed impedances and decoupling capacitors on the connected PCB to attenuate the power supply voltage ripple. The series impedance can be either a low value resistor or a small inductor. The extra decoupling capacitance must not exceed the value specified in Table 13.

The AVDD and AVSS outputs are overload protected. An overload of these outputs will cause a power down of the amplifier together with all auxiliary power supply outputs except for DVDD and DVDDstby. When the overload condition is removed the amplifier and auxiliary output will automatically restart after a short delay.

Timing of the AVDD and AVSS overcurrent event is shown in Figure 22 and specific timing values are available in Section 8.4.

11.5 Advanced Control and Status

The Advanced Control and Status connector includes control auxiliary power supply outputs DVDD and DVDDstby identical to those in the Basic Control and Status connector and the following features:

- STBY output
- ON output
- AmpReady output
- Temp output
- TempWarning output
- Ilim1 and Ilim2 outputs
- Trigger input
- SignalSense+ and SignalSense- inputs

The recommended connection to the control input and status outputs are shown on Figure 30 and Figure 31 in Section 12.

11.5.1 STBY Output

The STBY output indicates that the 1200AS is in standby mode by a low on the STBY output.

When the 1200AS is brought out of standby mode, by use of either the Standby input, the Trigger input or the SignalSense inputs, the STBY output will be released after a short delay $t_{\text{STBY-release}}$. In combination with the ON output, this short delay on the STBY output will indicate that the 1200AS is starting up.

The STBY output timing is shown in Figure 24 together with ON output timing.

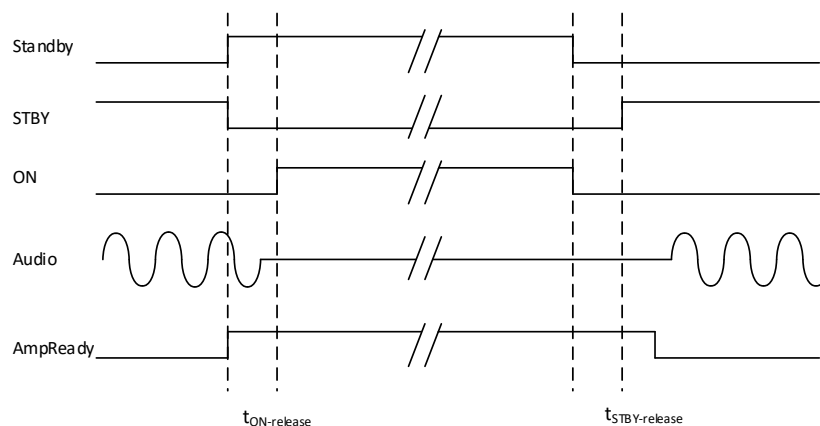

Figure 24: STBY and ON output timing

The STBY output is an open-collector output pulled high by external pull-up resistor. Interface schematics can be found in Section 12.4.

11.5.2 ON Output

The ON output indicates that the 1200AS is in on-mode by a low on the ON output.

The ON output will go low when the 1200AS is brought out of standby-mode by use of either the Standby, Trigger or SignalSense inputs.

When power is removed from the module or when the module is brought into standby-mode, the ON output will be released after a short delay $t_{\text{On_release}}$. In combination with the STBY output, this short delay on the ON output will indicate that the 1200AS is powering down.

The ON output timing is shown in Figure 24 together with STBY output timing.

The ON output is open-collector output pulled high by external pull-up resistor. Interface schematics can be found in Section 12.4.

11.5.3 AmpReady Output

The AmpReady output indicates by a low on the output that the 1200AS amplifier section has passed all system checks and that audio, if present on the analog input, is reproduced on the speaker outputs.

In case of a potentially destructive error in the 1200AS amplifier section, the amplifier will shut down and indicate this by releasing the AmpReady output.

AmpReady timing is shown in Figure 25.

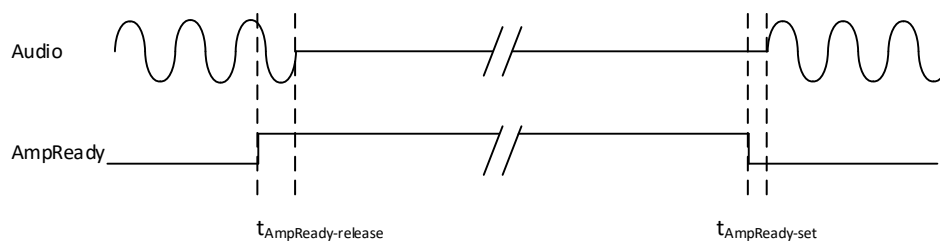

Figure 25: AmpReady output timing

The AmpReady is an open-collector output pulled high by external pull-up resistor. Interface schematics can be found in Section 12.4.

11.5.4 Temp Output

The Temp output reports the module temperature on a linear scale. As the temperature is measured on several places across the 1200AS, the highest measured temperature is reported.

Any measured temperature below the temperature range specified in Section 8.3 will be reported as the lowest value of the range.

During thermal shutdown, the Temp output continues to report the measured temperature.

The Temp output is an analog output. Interface schematics can be found in Section 12.2.

11.5.5 TempWarning Output

The TempWarning output indicates by a low on the output that the amplifier or the power supply has reached a critical temperature. The trigger temperatures for TempWarning output are $T_{\text{Amp-OT-warning}}$ and $T_{\text{PSU-OT-warning}}$ as specified in Section 8.3 for the amplifier and power supply respectively. The TempWarning output can be used as information only or for more active purposes e.g. fan control or signal reduction in front end.

The TempWarning output is released automatically when the module temperature is below the trigger values again.

The TempWarning output is an open-collector output pulled high by external pull-up resistor. Interface schematics can be found in Section 12.4.

11.5.6 Ilim1 and Ilim2 Outputs

The Ilim1 and Ilim2 outputs indicate by a low on the output that an overcurrent event has happened in channel 1 or channel 2 output respectively.

As the current limiting function in the amplifier is based on a cycle-by-cycle detection system, each overcurrent pulse is very short. To make these pulses easier to detect by a signal front-end protection system or to make them clearly visible if LEDs are directly connected to the Ilim1 and Ilim2 outputs, the pulses are extended to a minimum length $t_{\text{Ilim-pulse}}$.

On the 1200AS1, the Ilim2 output is left unconnected.

The Ilim1 and Ilim2 outputs are open-collector outputs pulled high by external pull-up resistors. Interface schematics can be found in Section 12.4.

11.5.7 Trigger Input

When the 1200AS is in standby-mode set by a high on the Standby input, the module can be powered up by a high on the Trigger input. This can e.g. be used to switch on and off a remotely located amplifier. Figure 26 shows how the Trigger and Standby inputs are gated together with the SignalSense input. Please read Section 11.5.8 on more information on SignalSense.

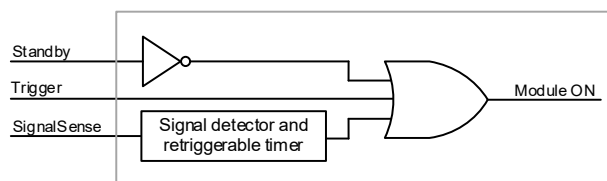

Figure 26: Standby, Trigger and SignalSense input overview

The Trigger input is designed to work correctly with standard logic circuits. However, it is tolerant to higher input voltages allowing it to be used directly as e.g. 12 V trigger in AVR applications or subwoofers.

11.5.8 SignalSense+ and SignalSense- Input

To enable automatic module power up when audio is applied to the input of an end-product including a 1200AS module, a dedicated signal sense input pair is available on the SignalSense+ and SignalSense- inputs.

When the 1200AS is in standby-mode set by a high on the Standby input and a low on the Trigger input, the module will go into normal operation mode if an audio signal above the signal sense trigger threshold $V_{\text{Trig-SignalSense}}$ is detected on the signal sense inputs. An overview is given in Figure 26.

Each time an audio signal is detected on the SignalSense inputs, a timer is restarted keeping the 1200AS in operation mode for time duration $t_{\text{SignalSense}}$ after the last detected audio signal. While the 1200AS SignalSense timer is active, the module cannot be set in standby-mode.

By having the signal sense input on a separate connector instead of directly on the audio inputs on the module, it is possible to connect the signal sense to the input of a front-end circuit. In this way, the signal sense will work even if the front-end circuits are powered down in standby-mode.

The SignalSense+ and SignalSense- inputs are a high impedance fully differential input pair. The inputs are low pass filtered to reduce the risk of false triggers from high frequency spikes.

11.5.9 DVDD and DVDDstby Power Supply Output

The DVDD and DVDDstby power supply outputs on the Advanced Control and Status connector are identical to those in the Basic Control and Status connector. Please read Section 11.4.5 for use of these outputs.

11.6 Voltage and Current Monitor Outputs

The Voltage and Current Monitor output connector provides real time representations of the speaker connector output voltage and current. For advanced applications, this information can enable e.g. accurate power calculation, compensation of nonlinearities in the speaker driver and advanced speaker driver protection.

11.6.1 Vmon1 and Vmon2 Output

The Vmon1 and Vmon2 outputs are amplitude and phase true representations of the speaker connector output voltage in channel 1 and channel 2 respectively. The Voltage monitor output gain A_{Vmon} , as specified in Section 8.2, is designed so that a full scale unclipped audio signal on the speaker outputs can be presented within the Vmon output voltage range.

For the 1200AS1 module, the Vmon2 output is left unconnected.

Vmon1 and Vmon2 are analog outputs. Interface schematics can be found in Section 12.2. To get best possible signal to noise ratio on the Vmon outputs, it is recommended to use a differential input on the front-end board and use the respective GNDS as ground sense.

11.6.2 Imon1 and Imon2 Output

The Imon1 and Imon2 outputs are amplitude and phase true voltage representations of the speaker connector output current in channel 1 and channel 2 respectively. The current sense circuit is based on a very low value series sense resistor in the amplifier speaker output followed by a gain stage. The resulting equivalent current sense resistor, as specified in Section 8.2, is designed so that the current flowing in the speaker output when driving a full scale unclipped audio signal into the minimum specified load impedance can be represented within the Imon output voltage range.

For the 1200AS1 module, the Imon2 output is left unconnected.

Imon1 and Imon2 are analog outputs. Interface schematics can be found in Section 12.2. To get best possible signal to noise ratio on the Imon outputs, it is recommended to use a differential input on the front-end board and use the respective GNDS as ground sense.

11.7 Hanger Rail Supply

To supply an optional amplifier channel on the 1200AS, the amplifier power stage positive and negative supply lines VD and VS together with power ground GND are available in the Hanger Rail Supply connector.

WARNING: As the VD and VS power outputs are NOT over-current protected, a fast acting 5 A fuse MUST be included in the supply line on the hanger amplifier PCB. Failure to comply with this requirement is against the ICEpower warranty policy.

11.8 Hanger Control

The Hanger Control connector must be used with ICEpower hanger modules only. Use of these connections for any other purpose is against the ICEpower warranty policy.

12 Interface Schematics

In the following sub-sections, proposed interface schematics are shown. These schematics should be considered an assistance to the design process, and they represent the recommended interface to the 1200AS module.

12.1 Audio Input

Generic interface for fully differential use of the analog inputs.

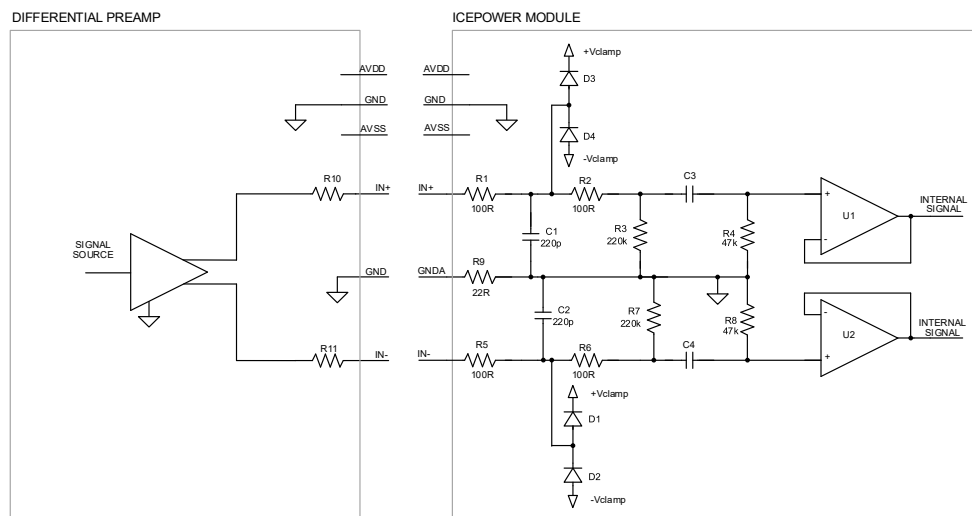

Figure 27: Fully balanced audio input interface schematics

Generic interface for semi-balanced use of the analog input.

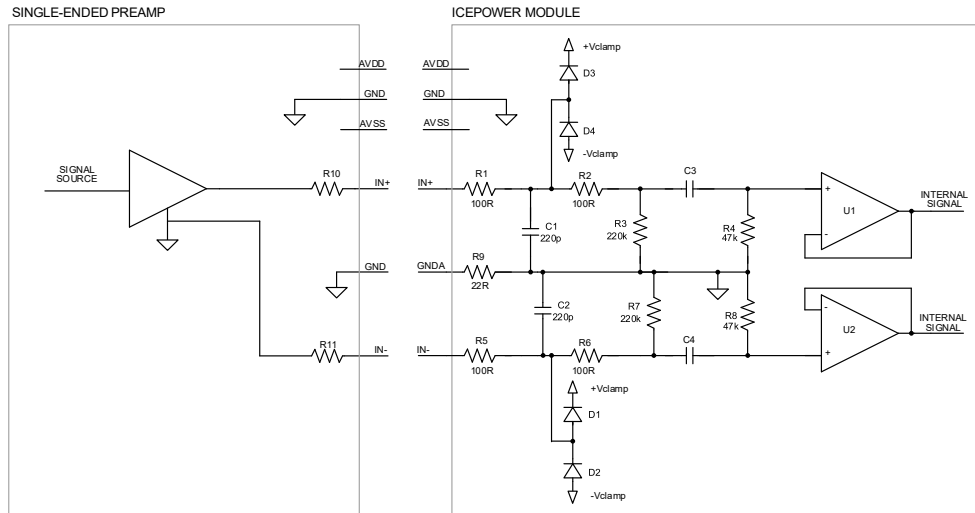

Figure 28: Semi-balanced audio input interface schematics

12.2 Analog Output

Generic interface for analog output signals e.g. Imon and Vmon outputs.

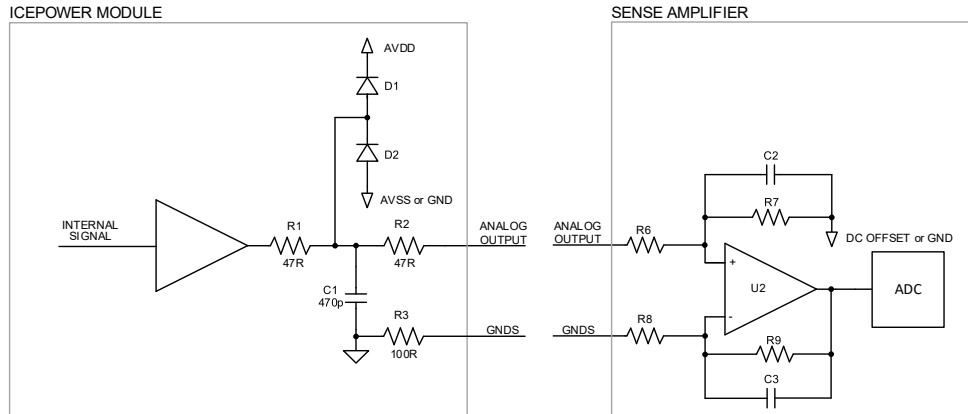

Figure 29: Analog output interface schematics

12.3 Control Input

Generic interface for all control inputs.

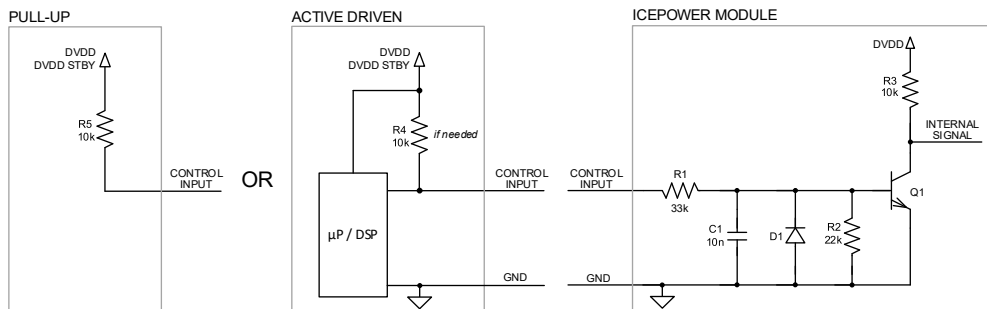

Figure 30: Control input interface schematics

12.4 Status Output

Generic interface for all status outputs.

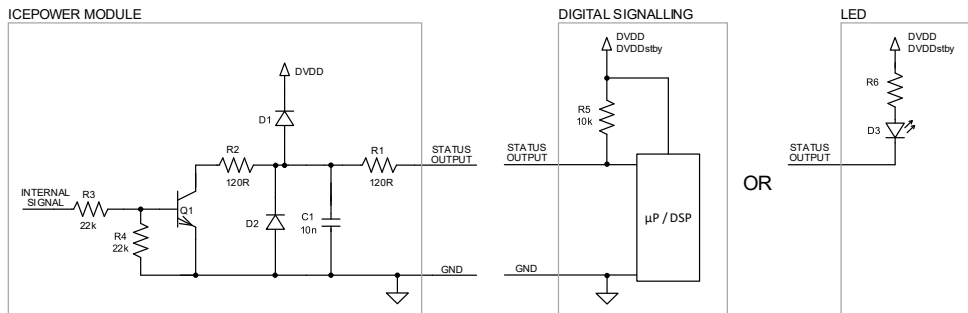

Figure 31: Status output interface schematics

13 Integration Guidelines

The ICEpower1200AS is designed with ease of integration in mind. This includes both electrical, EMC, thermal and mechanical integration. In the following sub-sections, recommendations will be given to assist the end-product design process.

13.1 Grounding Scheme

Depending on the complexity of the end-product several grounding schemes can be used. On Figure 32 an example of the grounding scheme usable on the 1200AS module is shown for a simple setup including a front-end PCB.

The low value series resistors included in the signal shield connections prevent ground loops between the 1200AS module and the front-end PCB. To prevent similar ground loops between the PCBs and the chassis, it is recommended not to connect the audio input connectors to the chassis but to have them grounded on the front-end PCB.

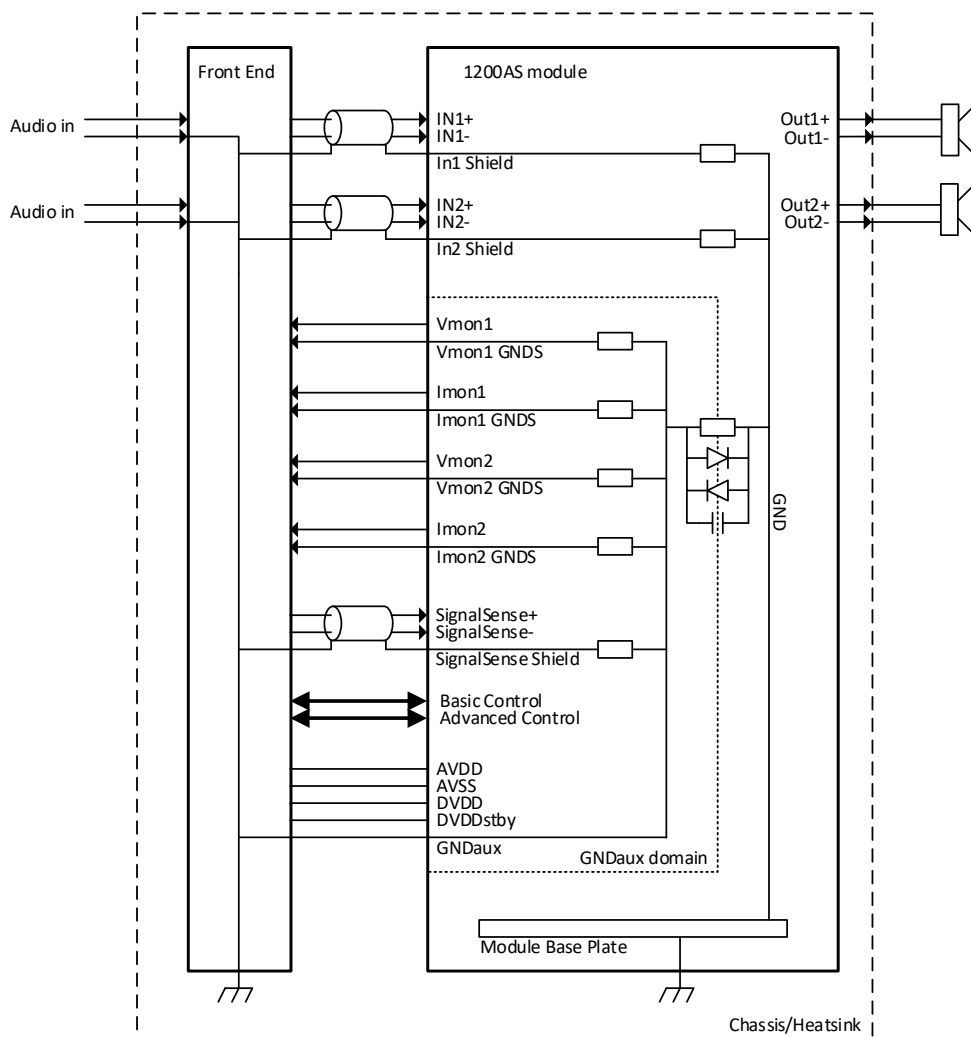

Figure 32: Grounding scheme

13.2 EMC Management

As described in Section 2, the ICEpower1200AS is EMC pre-approved as is when mounted on a standard aluminum open back plate. However, because of the high-power switching electronics included in the module, some EMC precautions are required to ensure an EMC approvable end-product design.

- Connect the module baseplate to the chassis. Mounting of the module isolated from the chassis may cause extended HF radiation.
- Do not use cable/wires between module and other PCBs that are longer than necessary.
- Avoid wire loops on the speaker output wires. Use wires closely paired side by side or if required use twisted or shielded cables (Figure 33)
- Avoid wire loops on the mains wires from the mains inlet to the module mains connector.
- Do not route cables near by the magnetic components on the module i.e. inductors and transformers.
- Do not bundle mains wires together with other cables (Figure 34).
- Do not bundle speaker wires together with other cables (Figure 34).

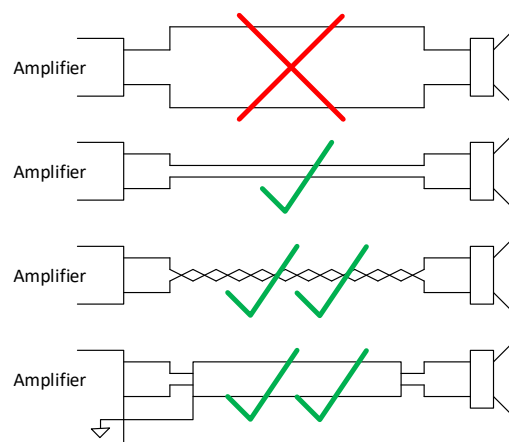

Figure 33: Speaker wire routing

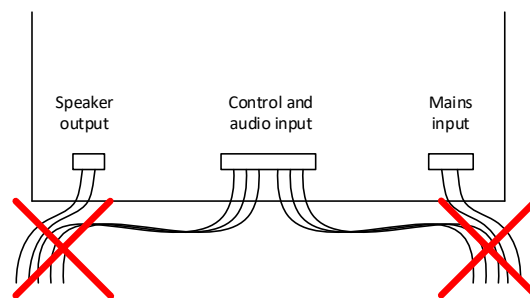

Figure 34: Wire bundling

Depending on the end-product application, additional EMC initiatives and filtering may be required to have the entire product approved. The reason for this could be, among others, insufficient cable routing within the application or DSP/microprocessor based front-end systems.

To improve on EMC performance, it is often advisable to revisit the used grounding scheme and cable routing and add EMC filters on some or all of the connectors on the end-product.

13.3 Thermal Design

The ICEpower1200AS module is designed with an integrated cooling system in the aluminum base plate. The module can therefore operate without any further cooling however at reduced power levels. Even though use of the module without further cooling is possible, it is recommended to add more cooling.

In most applications, the module will be additionally cooled through the aluminum chassis or heatsink on which it is mounted. As specified in Section 2, a 0.8K/W heatsink has been used as cooling for the power specification in this datasheet.

Besides cooling through the baseplate, it is important to ensure proper airflow around the module. In most cases, this can be achieved through passive convection, but in some cases e.g. rack enclosures, forced airflow may be required depending on end-product mechanical design constraints or end-product use environment.

14 Mechanical Mounting

As described in Section 13.3, the ICEpower1200AS modules are designed for mounting in an aluminum chassis or on a heatsink for added cooling through the aluminum base plate. To give flexibility in the mechanical solutions in different applications, two mountings methods are possible:

- Mounting from the bottom side through 18 pieces of M3 threaded holes.
- Mounting from the top side through 12 recesses along the two long sides of the module.

The 18 circular holes on Figure 3 indicate standoffs with internal M3 threading, used to mount the module PCB to the module base plate. These standoffs have free thread from the bottom side, which can be used for mounting the module. When choosing screws for the mounting, the depth of the threaded holes must be observed as well as the specified mounting torque, both specified in Section 9.1.

Alternatively, the module can be mounted from the top side by use of twelve recesses in the module PCB and base plate along the edges. Standard 3 mm or 1/8 inch non-countersunk screws are recommended.

When designing the chassis or heatsink solutions for the 1200AS module, the metal part surface flatness must be controlled to avoid bending or flexing of the module. Additionally, uneven contact surface will result in non-optimal thermal interface.

Finally, thermal conductive compound may be used in the mechanical interface between module and chassis/heatsink if required. Please follow the instructions provided by the thermal compound manufacture as incorrect use can result in non-optimal performance.

15 Safety and EMC Standards

The ICEpower1200AS family products have been verified to conform to the following standards.

15.1 Safety

Following standards incl. compliance with the National requirements of AR, AT, AU, BE, CA, CN, CH, CZ, DE, DK, ES, FI, FR, GB, HU, IE, IL, IT, JP, KR, MY, NL, NO, PL, SE, SG, SK, SI and US.

IEC 62368-1:2014 (Second Edition)
IEC 62368-1:2014 / A11: 2017
UL 62368-1 and CAN/CSA C22.2 No. 62368-1-14

IEC 60065:2014(8th edition)
IEC 60065 7th edition Amd1 + Amd2

EN60065:2014
EN 60065: 2002/A1:2006; EN 60065:2002/A11:2008; EN
60065:2002/A2:2010; EN 60065:2002/A12:2011

15.2 EMC

EN 55032: 2015
(CISPR 32: 2015)

Electromagnetic compatibility of multimedia equipment
– Emission requirements – Class B

EN 61000-3-2: 2014
(IEC 61000-3-2: 2014)

Harmonic current emission

EN 61000-3-3: 2013
(IEC 61000-3-3: 2013)

Voltage changes, voltage fluctuations and flicker

CFR 47 Part 15 Subpart B (FCC): 2016

Telecommunication – Radio Frequency Devices –
Unintentional Radiation – Class B

EN55020: 2007 + A11: 2011
(CISPR 20: 2006)

Sound and television broadcast receivers and associated
equipment – Immunity characteristics – Limits and
methods of measurement

EN 61000-4-2: 2009
(IEC 61000-4-2:2008)

Electrostatic discharge immunity test

EN 61000-4-3: 2006 + A1: 2008 + A2: 2010
(IEC 61000-4-3: 2006 + A1: 2007 + A2: 2010)

Radiated, radio frequency, electromagnetic field
immunity test

EN 61000-4-4: 2004 + A1: 2010
(IEC 61000-4-4: 2004 + C1: 2006 + C2: 2007
+ A1: 2010)

Electrical fast transient / burst immunity test

16 ESD Warning

ICEpower products are manufactured according to the following ESD precautions:

ANSI/ESD-S20.20-2014: Protection of Electrical and Electronic Parts, Assemblies and Equipment.

Further handling of the products should comply with the same standard.

The general warranty policy of ICEpower a/s does not cover ESD damaged products due to improper handling.

17 Ordering, Packaging and Storage

All ICEpower modules are packaged in ESD safe bubble bags and cardboard boxes.

17.1 Ordering Information

Order Codes	Description	Part Number
ICEpower1200AS1	One channels 1200 W ICEpower amplifier with integrated universal mains power supply	8008222
ICEpower1200AS2	Two channels 1200 W ICEpower amplifier with integrated universal mains power supply	8008142

17.2 Shipping Dimensions and Weight

Package	Quantity	Dimensions (w × d × h) [mm]	Gross Weight [kg]
Carton	7	390 × 590 × 195	10.8

17.3 Storage Conditions

Storage Humidity and Temperature:

Please find storage humidity and temperature information in Section 9.3, Environmental Specifications.

Stacking

A maximum of 4 cartons must be stacked on top of each other.

Pallets must not be stacked on top of each other.

18 Contact

For additional information about the ICEpower® technology from ICEpower a/s, visit our web site or contact us.

ICEpower a/s
Vandtårnsvej 62A 3B
DK-2860 Søborg
Denmark

Phone +45 31 71 00 01

www.icepower.dk
info@icepower.dk

19 Legal Notes

ICEpower a/s believes that the information in this datasheet is accurate and reliable. However it is provided "as is" without any warranties of any kind. ICEpower a/s and its suppliers, to the fullest extent permitted by law, disclaim all warranties, including the warranty of merchantability, warranty of non-infringement of third-party rights, and the warranty of fitness for a particular purpose. ICEpower a/s and its suppliers make no warranties about the accuracy, reliability, completeness, or timeliness of the material, services, software, text, graphics and links. In no event will ICEpower a/s be liable to any party for any damages whether direct, indirect, special, consequential or other for any use or inability to use of this datasheet, including, without limitation, any damages for lost profits, business interruption, loss of programs or other data on your information handling system or otherwise, even if we are expressly advised of the possibility of such damages.

Information in this datasheet may contain technical inaccuracies or typographical errors. The information in the datasheet may be changed at any time without prior notice or obligation.

ICEpower® is a trademark of ICEpower a/s.

ICEpower a/s products are not authorized for use as critical components in life support devices or life support systems without the express written approval of the president and general counsel of ICEpower a/s. As used herein:

- Life support devices or systems are devices or systems which, (a) are intended for surgical implant into the body, or (b) support or sustain life, and whose failure to perform when properly used in accordance with instructions for use provided in the labelling, can be reasonably expected to result in a significant injury to the user.
- A critical component is any component of a life support device or system whose failure to perform can be reasonably expected to cause the failure of the life support device or system, or to affect its safety or effectiveness.

ICEpower a/s ©2018