

Data sheet  
Version 1.3

# ICEmatch

ICEpower400SM – Power Supply Module

ICEpower80AM2 – Audio Amplifier Module

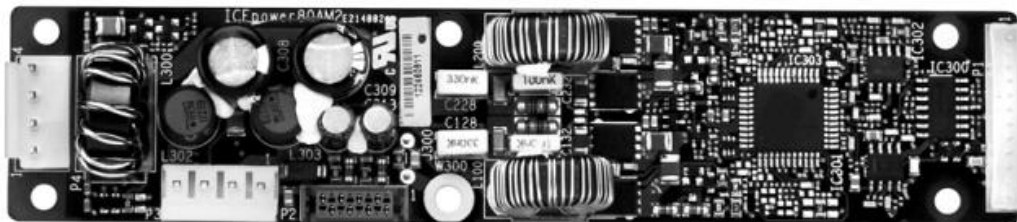
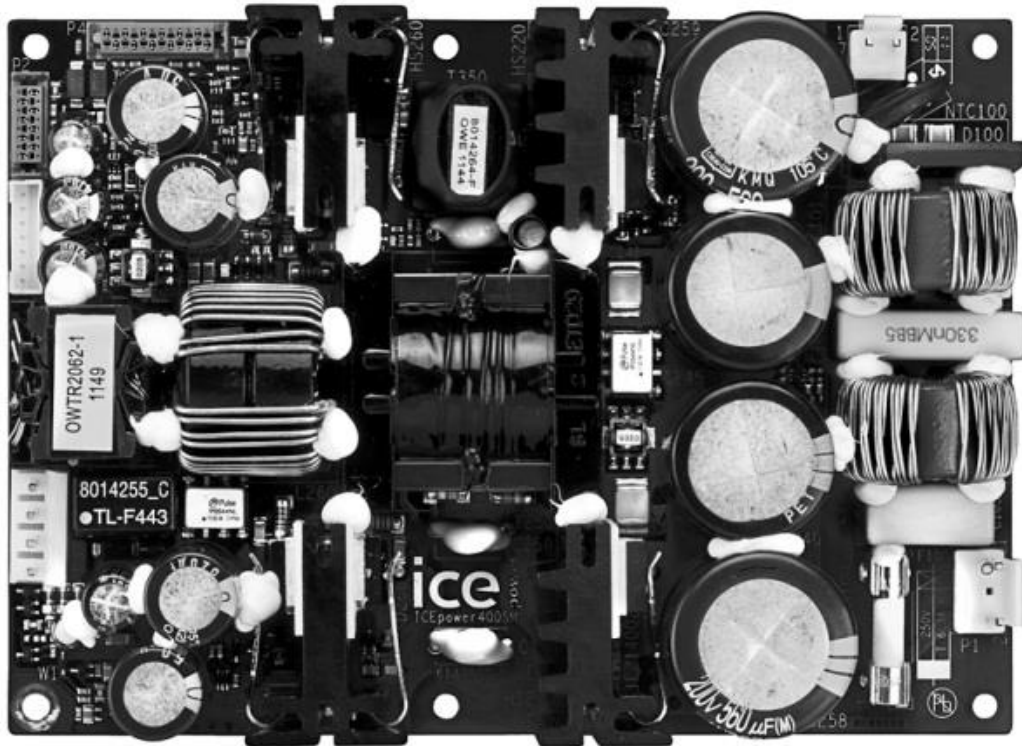

## Contents

<b>General Description</b> .....	<b>4</b>
<b>Release Notes</b> .....	<b>5</b>
<b>Typical ICEmatch Application Block Diagram</b> .....	<b>6</b>
<b>ICEpower400SM</b> .....	<b>7</b>
Block Diagram .....	7
Absolute Maximum Ratings .....	8
Thermal Specifications .....	9
Electrical Specifications General .....	10
Available $\pm 12V$ Auxiliary Supply Current .....	11
Connections .....	12
Connector Pin Description .....	12
External Interfacing ICEpower400SM .....	14
Mains Input .....	14
$\pm 12V$ auxiliary voltages .....	14
5V Standby Converter .....	14
CA_Vclip_mon .....	15
LED_prog .....	16
On/off control (12V trigger, 3-5V trigger and Signal_Sense) .....	16
Protection Features .....	18
Main Converter .....	18
Auxiliary Converter .....	18
Standby Converter .....	19
Physical Dimensions .....	20
Drill Pattern .....	22
<b>ICEpower80AM2</b> .....	<b>23</b>
Block Diagram .....	23
Absolute Maximum Ratings .....	24
Thermal Specifications .....	25
General Audio Specifications (SE mode) .....	26
General Audio Specifications (BTL mode) .....	27
Electrical Specifications .....	28
Typical Performance Characteristics – Single Ended Mode .....	29
Frequency Response .....	29
Total Harmonic Distortion + Noise .....	29
Idle Noise and Low Power Spectrum .....	30
Intermodulation Distortion .....	30
Typical Performance Characteristics – BTL Mode .....	31
Frequency Response .....	31
Total Harmonic Distortion + Noise, BTL .....	31
Idle Noise and Low Power Spectrum, BTL .....	32
Intermodulation Distortion, BTL .....	32
Typical Performance Characteristics – 16 Channel System – Single Ended Mode .....	33
Total Harmonic Distortion + Noise: 1 to 16 channels driven .....	33
Cross Talk .....	34
Typical Performance Characteristics – 8 Channel System – BTL Mode .....	35
Total Harmonic Distortion + Noise: 1 to 8 channels driven .....	35
Cross Talk, BTL .....	36
Output Impedance – Single Ended Mode .....	37
Capacitive loading – Single Ended Mode .....	37
Output Impedance – BTL Mode .....	38
Capacitive loading – BTL Mode .....	38
Connection Diagram .....	39

Connector Pin Description.....	39
External Interfacing .....	41
External Signal/Control (P1).....	41
Amplifier Output (P4).....	43
Protection Features.....	45
Thermal protection .....	45
Amplifier Output Current Limiter .....	45
Output Filter (Zobel) and HF Output Protection .....	45
DC Detector .....	45
Physical Dimensions .....	46
<b>System Design .....</b>	<b>48</b>
Thermal Design .....	48
Recommended module placement and wiring within a 19" rack cabinet .....	48
EMC Design.....	50
Typical Timing Specifications .....	51
<b>Environmental Specifications .....</b>	<b>52</b>
<b>Safety Standards .....</b>	<b>52</b>
<b>Touch Current .....</b>	<b>52</b>
<b>Disturbances on the Mains.....</b>	<b>52</b>
<b>EMC .....</b>	<b>53</b>
<b>Electrostatic Discharge .....</b>	<b>53</b>
<b>Environmental and Reliability Tests.....</b>	<b>53</b>
<b>Mechanical Tests.....</b>	<b>54</b>
<b>ESD Warning .....</b>	<b>54</b>
<b>Packaging and Storing .....</b>	<b>55</b>
Dimensions and weight ICEpower400SM .....	55
Dimensions and weight ICEpower80AM2 .....	55
ICEmatch Order Codes.....	55
Stacking.....	55
<b>Contact .....</b>	<b>56</b>
<b>Legal Notes .....</b>	<b>56</b>

## General Description

The ICEmatch series is offering a new highly flexible approach towards fully integrated, intelligent audio power conversion, intended for activation of loudspeakers and custom installation amplifiers.

Key benefits include:

- State-of-the-art, high efficiency ICEpower Class D amplification stage based on the patented HCOM modulation and MECC control techniques
- A regulated high efficiency ICEpower Supply with universal mains converter ensuring high performance independently of mains voltage
- On board standby converter with less than 0.5W power consumption from mains with 0.25W as payload.
- Compact module size fits directly into a 1U rack system, enabling up to 16 channels in one 19" cabinet
- The ICEmatch modules are EMC and Safety pre-approved and the "black-box" completeness allows for fast design-in and minimized time to market

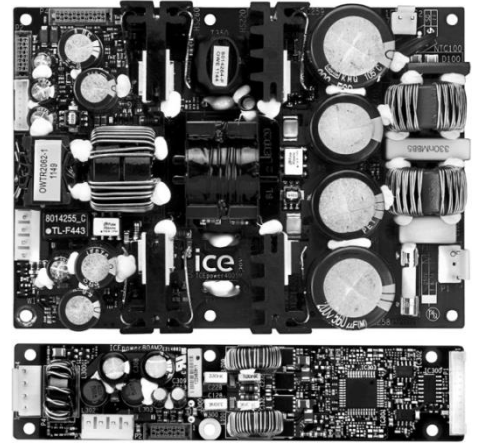

The ICEmatch module series with its on-board heat sink eliminates the need for additional bulky heat sinks and heavy mains transformers. The unique flexibility and intelligent features make the ICEmatch modules the natural choice in multi-channel audio applications, custom installation systems and active speaker designs.

The ICEmatch modules are protected against short circuits, over load, overheating and DC on output.

The integrated protection scheme ensures music at all times until the predefined maximum limits are reached and a safe shutdown is required.

The solution includes an on-board fuse and EMI filtering to provide an EN and FCC pre-approved subsystem.

### Key Specifications ICEpower80AM2

2x80W @ 0.03% THD+N, 20Hz – 20kHz, 4Ω, SE  
 160W @ 0.04% THD+N, 20Hz – 20kHz, 8Ω, BTL  
 Max output voltage / current: 28V<sub>p</sub> / 20A<sub>p</sub>, 4Ω, SE  
 Max output voltage / current: 56V<sub>p</sub> / 20A<sub>p</sub>, 8Ω, BTL  
 110dBA dynamic range  
 Idle noise = 50uV, A-weighted, 20Hz – 20kHz, SE  
 THD+N = 0.002% @ 10W, 1kHz, 4Ω, SE

### Key Specifications ICEpower400SM

Supply for up to 400W amplifier output power  
 Universal Mains 85-264V<sub>AC</sub>  
 Standby power consumption < 0.5W  
 +/-12V AUX supply 700mA  
 +5V Aux supply 1.0A

### Key Features

High quality audio amplification system  
 Highly flexible system modularity  
 Compact size fits 1U 19" rack systems  
 Fully integrated audio power solution  
 Thermal protection  
 Over current protection  
 Protection against DC on output  
 Control pins allow easy control and status indication  
 EMI conforms to:  
 EN55013  
 EN55020  
 EN61000-3-2  
 EN61000-3-3  
 CISPR 13  
 CISPR 20  
 IEC 61000-3-2  
 IEC 61000-3-3  
 FCC part 15-B  
 EN 55032: see note 1  
 Safety conforms to:  
 IEC 60065 7<sup>th</sup> ed.\*, IEC 60065 8<sup>th</sup> ed  
 UL 60065 7<sup>th</sup> ed.\*  
 \*including tropical climate conditions 45°C ambient  
 IEC 62368-1:2014 2nd ed.  
 UL 62368-1 2nd ed.

## Release Notes

Version	Date	Revised by	Description
1.0	2017-09-05	LBH/DIT	Output voltage / current spec. added Safety and EMI standards updated Address updated Legal Notes added
1.1	2018-02-02	LBH/DIT	Environmental specifications updated Ambient temperature operating added
1.2	2018-04-18	LBH/DIT	Safety standards updated 62368-1:2014 2nd ed.
1.3	2018-11-06	LBH/DIT	Absolute Maximum Ratings and External Interfacing updated

## Typical ICEmatch Application Block Diagram

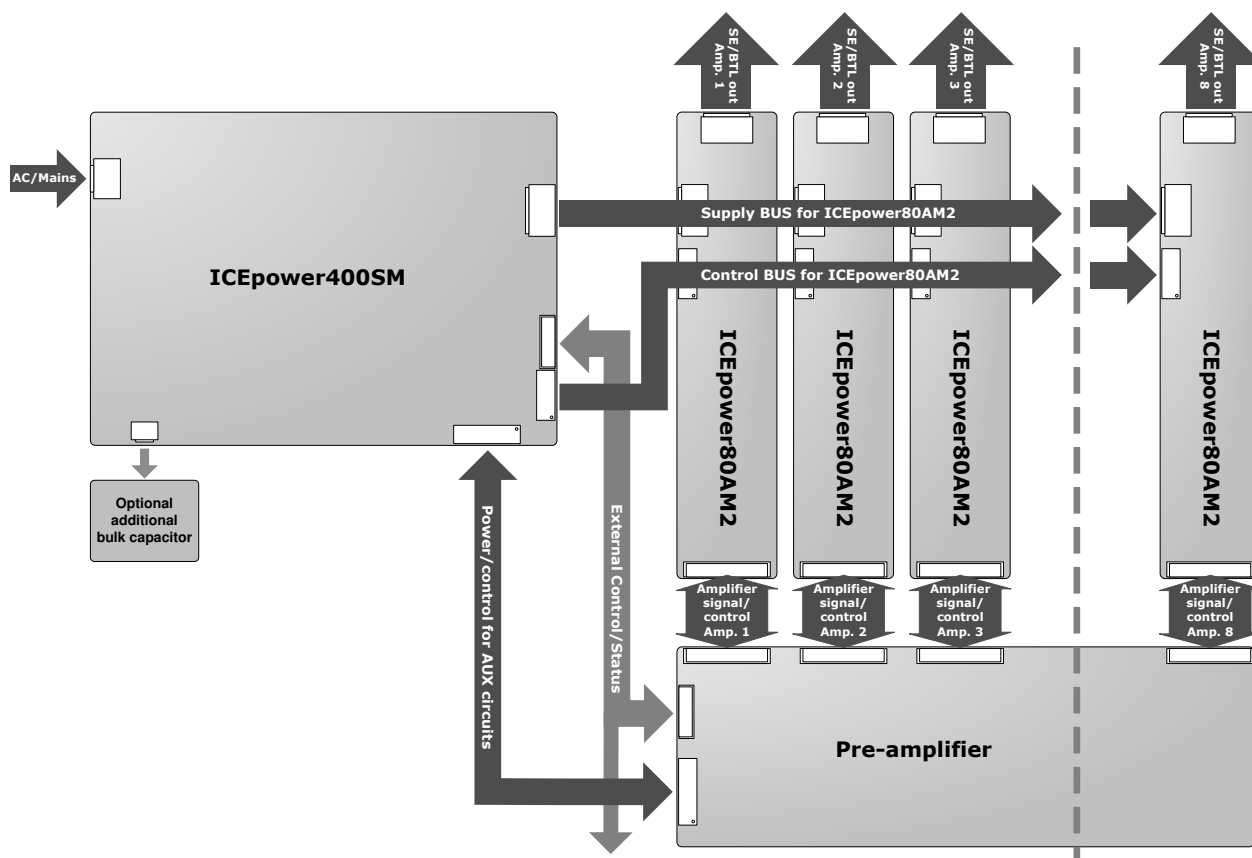

Figure 1 Block diagram ICEmatch

A typical ICEmatch application consists of one ICEpower400SM power supply module and up to eight ICEpower80AM2 audio amplifier modules. Each amplifier module can be configured as either a two channel amplifier of 2 x 80W into 4Ω or as a bridged single channel amplifier of 1 x 160W into 8Ω.

Furthermore, the ICEpower400SM power supply will provide +5V and +/-12V for a preamplifier, crossover, DSP and microprocessor board and includes interface for external circuits such as LED drive and 12V trigger input. A high efficiency standby converter is also included which will enable remote on/off, startup on audio signal and other typical standby functions.

Connection for an optional additional 400V DC bulk capacitor is also provided to enhance low frequency audio power performance in countries having extreme low mains voltages.

# ICEpower400SM

The ICEpower400SM is a true universal mains 400W switch mode power supply operating from 85Vac to 264Vac utilizing ICEpower patented technology. It provides power for up to eight ICEpower80AM2 amplifier modules as well as for customer preamplifier/processor modules and includes LED drive, monitoring and control signals.

The supply outputs are protected against overload and short circuit conditions and the power devices are protected against overheating.

The ICEmatch BUS (Supply BUS & Control BUS) are only to be used for interconnection between ICEpower400SM and a number of ICEpower80AM2. Please note that only up to 8 ICEpower80AM2 modules can be connected to the ICEpower400SM. Connecting more than 8 modules may cause a protective shutdown of the ICEpower400SM.

Note: Ensure sufficient clearance for live parts and adequate ventilation for safe and proper operation.

## Block Diagram

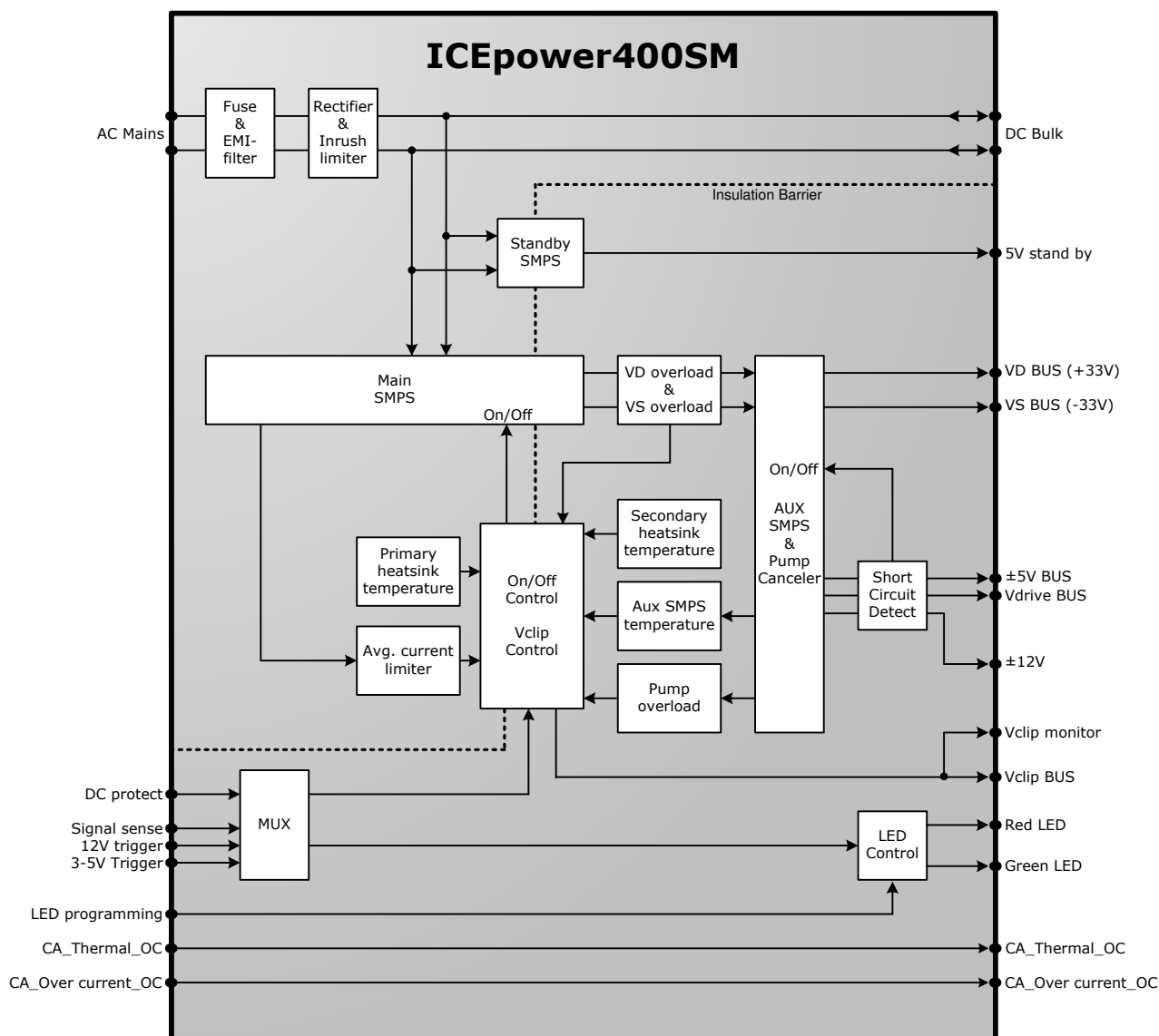

Figure 2: ICEpower400SM Block Diagram

## Absolute Maximum Ratings

Absolute maximum ratings indicate limits above which damage may occur.

### Mains Input Section

Symbol	Parameter	Value	Units
AC <sub>max</sub>	Maximum mains voltage (safety test)	264 <sup>1</sup>	V <sub>AC</sub>
AC <sub>min</sub>	Minimum mains voltage (safety test)	85 <sup>1</sup>	V <sub>AC</sub>
F <sub>mains</sub>	Mains frequency range 85VAC - 264VAC	45 – 65	Hz

Table 1: Absolute maximum ratings, mains input section

<sup>1</sup>The maximum operating/usage mains voltage is 240Vac and the minimum operating/usage mains voltage is 100Vac.

### Control pin Section

Symbol	Parameter	Value	Units
3-5V_Trigger	Maximum control voltage	47	V
12V_Trigger	Maximum control voltage	57	V
Signal_Sense+	Maximum voltage	±2.5	V <sub>p</sub>
Signal_Sense-	Maximum voltage	±2.5	V <sub>p</sub>
Signal_Sense+	Maximum current (clamping at ±2.5V, otherwise Z <sub>in</sub> > 1MΩ)	10	mA <sub>pk</sub>
Signal_Sense-	Maximum current (clamping at ±2.5V, otherwise Z <sub>in</sub> = 47kΩ)	10	mA <sub>pk</sub>

Table 2: Absolute maximum ratings, control pin section



## Thermal Specifications

Unless otherwise specified.  $T_a=25^{\circ}\text{C}$ ,  $f=1\text{kHz}$ ,  $R_L=4\Omega$ , 230V mains

Symbol	Parameter	Conditions	Min	Typ	Max	Units
$t_{P_{max}}$	Time of maximum output power Limited by ICEpower400SM	$5 \times 80\text{W} = 400\text{W}$ 3 x ICEpower80AM2, 4 $\Omega$ SE	-	80	-	s
$P_T$	Continuous total amplifier output power without thermal shutdown. Limited by ICEpower400SM, 230VAC	Thermal stab. @ $T_a = 25^{\circ}\text{C}$ 3 x ICEpower80AM2, 4 $\Omega$ SE	-	80	-	W
$P_T$	Continuous total amplifier output power without thermal shutdown. Limited by ICEpower400SM, 115VAC	Thermal stab. @ $T_a = 25^{\circ}\text{C}$ 3 x ICEpower80AM2, 4 $\Omega$ SE	-	80	-	W
$P_T$	Continuous amplifier output power per channel without thermal shutdown. Limited by ICEpower400SM	Thermal stab. @ $T_a = 25^{\circ}\text{C}$ 8 x ICEpower80AM2, 4 $\Omega$ SE 16 channels	-	5	-	W
$P_{st.by}$	Quiescent power consumption, Standby, no load	115VAC 230VAC	- -	0.09 0.19	- -	W
$P_{st.by\_out}$	Maximum output power on 5Vst.by ensuring < 0.5W quiescent power consumption in standby mode	115VAC 230VAC	- -	- -	0.32 0.23	W
$P_q$	Quiescent power consumption, ICEpower400SM on mode, no load <sup>1)</sup>	115VAC 230VAC	- -	4.2 7.8	- -	W

<sup>1)</sup> The ICEpower400SM is designed to run with a minimum load of a single ICEpower80AM2. Loading below the minimum load can result in out-of-spec performance.

Table 3: Power and Thermal specifications

## Electrical Specifications General

Unless otherwise specified,  $T_a=25^{\circ}\text{C}$ .

Symbol	Parameter	Conditions	Min	Typ	Max	Unit
$I_{\text{max.}+12\text{V}}$	Maximum rated output current	+12V AUX			700 <sup>1)</sup>	mA
$I_{\text{max.}-12\text{V}}$	Maximum rated output current	-12V AUX			700 <sup>1)</sup>	mA
$I_{\text{max.st.by}}$	Maximum rated output current	+5V <sub>st.by</sub> Standby mode			200	mA
$I_{\text{max.st.by.On}}$	Maximum rated output current	+5V <sub>st.by</sub> On mode			1.0	A
$C_{\text{max.DC.Bulk}}$	Maximum optional external capacitance	DC_Bulk 400V (P7)			780	$\mu\text{F}$
$C_{\text{max.st.by}}$	Maximum external capacitance	5V_Stb load = 25 $\Omega$			820	$\mu\text{F}$
$V_{5\text{V\_Stb.tol}}$	Tolerance of 5V_Stb	0A $\leq$ Load $\leq$ 1A		5		%
$V_{\pm 12\text{V.tol}}$	Tolerance of $\pm 12\text{V}$	0A $\leq$ Load $\leq$ 700mA		10		%
$V_{5\text{V\_Stb.ripple}}$	Ripple of 5V_Stb	Load = 1A		100		mV <sub>pp</sub>
$V_{\pm 12\text{V.ripple}}$	Ripple of $\pm 12\text{V}$	Load = 700mA		100		mV <sub>pp</sub>
$V_{\text{trig.sig\_sense}}$	Signal sense - Trigger Level	Sine wave 75Hz-1kHz		1.3	3	mV
$V_{\text{trig.DC}}$	3-5V trigger – Trigger Level		1.8			V
$V_{\text{off.DC}}$	3-5V trigger – Off Level				0.8	V
$V_{\text{trig.12V}}$	12V trigger – Trigger Level		3.8			V
$V_{\text{off.12V}}$	12V trigger – Off Level				1.5	V
$I_{\text{min.LED}}$	Nominal output current	LEDprog Open		1.1		mA
$I_{\text{max.LED}}$	Nominal output current	LEDprog Shorted		7.4		mA
$V_{\text{max.LED.min.I}}$	Available output voltage at min. current	LEDprog Open		4.0		V
$V_{\text{max.LED.max.I}}$	Available output voltage at max. current	LEDprog Shorted		1.8		V
$f_{\text{smps.st.by}}$	Switching frequency (st.by power supply)	St.by mode	20	22	-	kHz
$f_{\text{smps.on}}$	Switching frequency (st.by power supply)	On mode	-	125	-	kHz
$f_{\text{smps.main}}$	Switching frequency (main power supply)		-	125	-	kHz
$f_{\text{smps.aux}}$	Switching frequency (AUX power supply)		-	150	-	kHz

<sup>1)</sup> The available auxiliary output current depends on the number of connected ICEpower80AM2 modules. See Table 5.

Table 4: Electrical specifications general

## Available $\pm 12\text{V}$ Auxiliary Supply Current

The available auxiliary supply current varies with the number of connected ICEpower80AM2 modules.

Unless otherwise specified,  $T_a=25^\circ\text{C}$ .

Symbol	Parameter	Value	Units
no_80AM2	1 to 4 ICEpower80AM2 modules	$\pm 700$	mA
no_80AM2	5 ICEpower80AM2 modules	$\pm 620$	mA
no_80AM2	5 ICEpower80AM2 modules	+1200 - 120	mA
no_80AM2	6 ICEpower80AM2 modules	$\pm 530$	mA
no_80AM2	6 ICEpower80AM2 modules	+950 - 110	mA
no_80AM2	7 ICEpower80AM2 modules	$\pm 440$	mA
no_80AM2	7 ICEpower80AM2 modules	+790 - 90	mA
no_80AM2	8 ICEpower80AM2 modules	$\pm 350$	mA
no_80AM2	8 ICEpower80AM2 modules	+630 - 70	mA

Table 5: Electrical specifications  $\pm 12\text{V}$  Auxiliary Supply

Due to the nature of the auxiliary supply, it is possible to draw up to 90% of the combined  $\pm 12\text{V}$  current from the +12V rail thus leaving 10% for the -12V rail.

## Connections

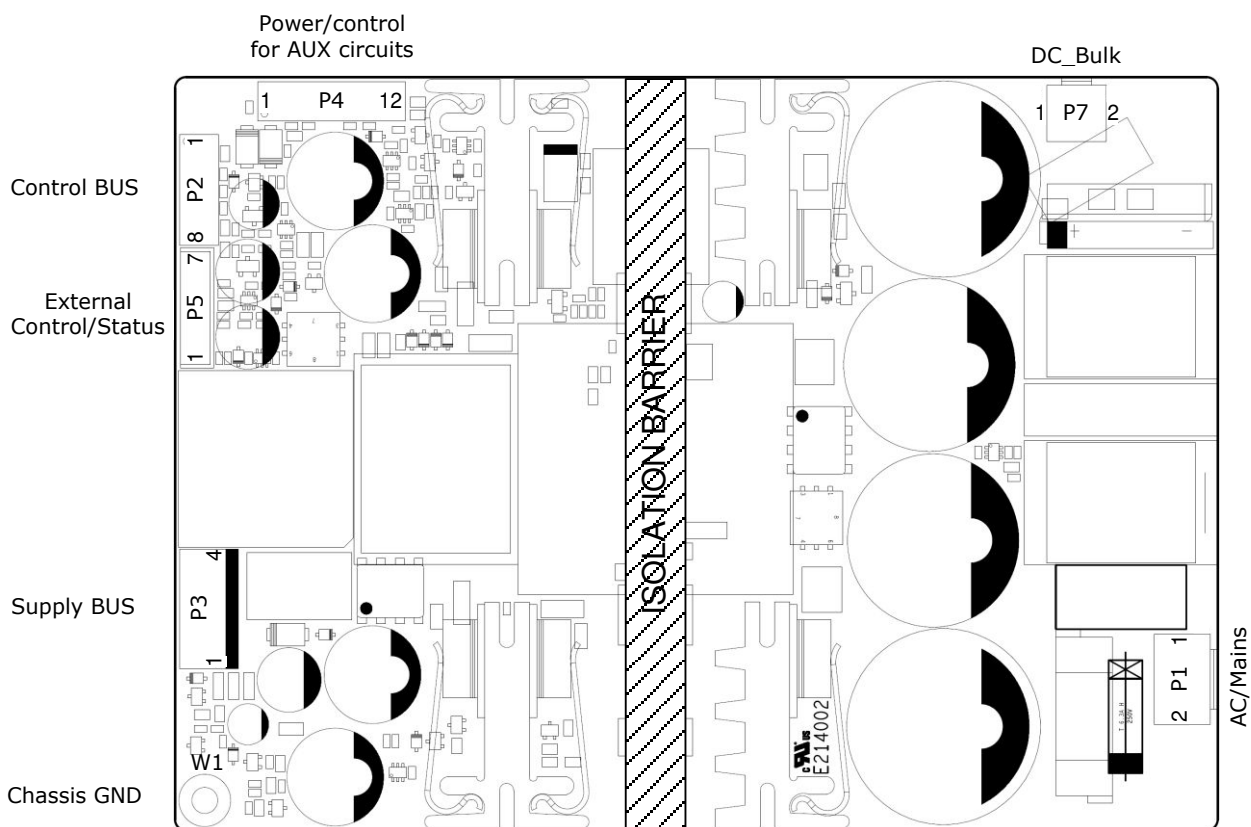

Figure 3: ICEpower400SM connections

The connector interface of the module uses industry standard connectors selected for long term reliability. For connector type number and description see Connector Pin Description.

## Connector Pin Description

### AC/Mains Header Specification (P1)

PCB part - Manufacturer: JST; MPN: B2P3-VH			
Pin	Designation	Description	Type
1	N	Mains Neutral	Input
		Voided	
2	L	Mains Live	Input

Table 6: AC/Mains connector specifications

### DC Bulk Header Specification (P7)

PCB part - Manufacturer: JST; MPN: B2P3-VH			
Pin	Designation	Description	Type
1	DC_bulk	Optional external DC bulk 400V capacitor (+)	Input
2	GNDp	Optional external DC bulk 400V capacitor (-)	Input

Table 7: DC Bulk connector specifications

### Amplifier Supply BUS Header Specification (P3)

PCB part - Manufacturer: JST; MPN: B4P-VR			
Pin	Designation	Description	Type
1	VD	Amplifier positive supply	Output
2	GNDA	Amplifier GND	GND
3	VS	Amplifier negative supply	Output
4	Vdrive	Vdrive supply voltage, +12V relative to VS	Output

Table 8: Amplifier Supply BUS connector specifications

### Amplifier Control BUS Header Specification (P2)

PCB part - Manufacturer: Tyco; MPN: 338068-8 (Micro-MaTch)			
Pin	Designation	Description	Type
1	CA_Vclip+	Reduce amplifier max out to protect SMPS.	Analog output
2	CA_Vclip-	Reduce amplifier max out to protect SMPS.	Analog output
3	GNDA	Amplifier GND	GND
4	VDD	+5V amplifier supply voltage	Output
5	VSS	-5V amplifier supply voltage	Output
6	CA_Thermal	Common amplifier thermal monitor	Input
7	CA_OC	Common amplifier over current monitor	Input
8	CA_DC_protect	Common amplifier DC protect	Input

Table 9: Amplifier Control BUS connector specifications

### Power/control for AUX Circuits Header Specification (P4)

PCB part - Manufacturer: Tyco; MPN: 1-338068-2 (Micro-MaTch)			
Pin	Designation	Description	Type
1	+12V	Pre-Amplifier supply voltage	Output
2	GNDB	GND for $\pm 12V$	GND
3	-12V	Pre-Amplifier supply voltage	Output
4	CA_Thermal	Thermal monitor (amplifier). Internal 10k $\Omega$ Pull-Up.	Output
5	CA_OC	Over current monitor (amplifier). Internal 10k $\Omega$ Pull-Up.	Output
6	CA_Vclip_mon	Vclip monitor	Analog Output
7	LED_prog	Input to program LED current	Analog Input
8	3-5V trigger	Control signal for power up on 3-5V logic	Input
9	5V_Stb	Standby voltage	Output
10	5V_Stb	Standby voltage	Output
11	GND	GND for 5V_Stb (digital GND)	GND
12	GND	GND for 5V_Stb (digital GND)	GND

Table 10: Power/control for AUX Circuits connector specification

## External Control/Status Header Specification (P5)

PCB part - Manufacturer: JST ; MPN: B7B-PH			
Pin	Designation	Description	Type
1	12V_trigger	12V trigger input	Input
2	GND	GND for 5V_Stb (digital GND)	GND
3	Signal_Sense+	Balanced input (+) for signal sense	Input
4	Signal_Sense-	Balanced input (-) for signal sense	Input
5	Red_LED	LED drive	Output
6	LED_Common	Common LED Terminal	Output
7	Green_LED	LED drive	Output

Table 11: External Control/Status connector specification

## External Interfacing ICEpower400SM

### Mains Input

The ICEpower400SM accepts any mains voltage in the range of 85V<sub>AC</sub> to 264V<sub>AC</sub> for flexibility and ease of logistics.

To reduce size and the total system cost, input bulk capacitors are optimized for full performance at nominal mains of 115VAC/60Hz and higher.

For mains voltages below 115VAC performance will be slightly reduced and therefore a connector for extra input DC bulk capacity is fitted on the PCB (P7). Adding additional DC bulk capacitance such as two 390uF/400V capacitors will boost performance at 100VAC.

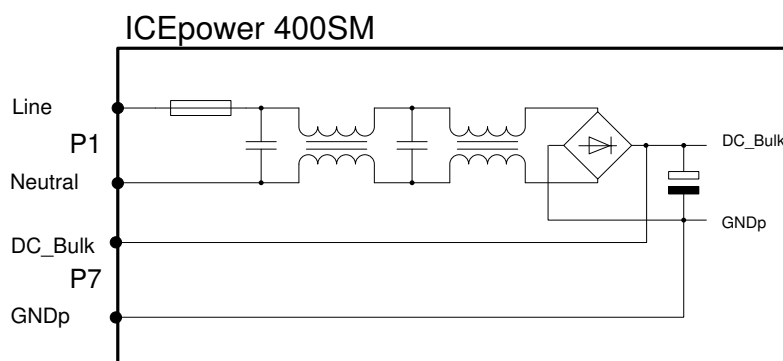

Figure 4: Connector for adding extra input bulk capacity

It is recommended to keep mains wires well away from especially the magnetic components as it can pick up switching noise and thus compromise EMC performance.

### ±12V auxiliary voltages

The ICEpower400SM is equipped with an auxiliary converter to supply the ICEpower80AM2 amplifiers with ±5V and 12V for the ICEpower Class D controllers and drivers respectively. These supply voltages are routed in the Supply Bus and Control Bus for the ICEpower80AM2 modules. These voltages should not be used for any other purpose.

The ICEpower400SM also features a separate ±12V output for external use. This output can supply up to 700mA and can be used for system control, DSP, microprocessor and preamp circuitry.

The ±12V auxiliary voltage is not available in standby mode.

### 5V Standby Converter

The ICEpower400SM is equipped with a separate 5V standby converter to supply external control circuitry. This output can supply up to 200mA in standby mode and 1.0A when the main SMPS is on.

Only the 5V standby supply voltage is available in standby mode.

The grounding of the 5V standby converter output (GND) has been DC isolated (100Ω GND impedance) from system ground (GND<sub>A</sub>) to avoid ground loops. It is recommended to use the ground connections as shown in Figure 5.

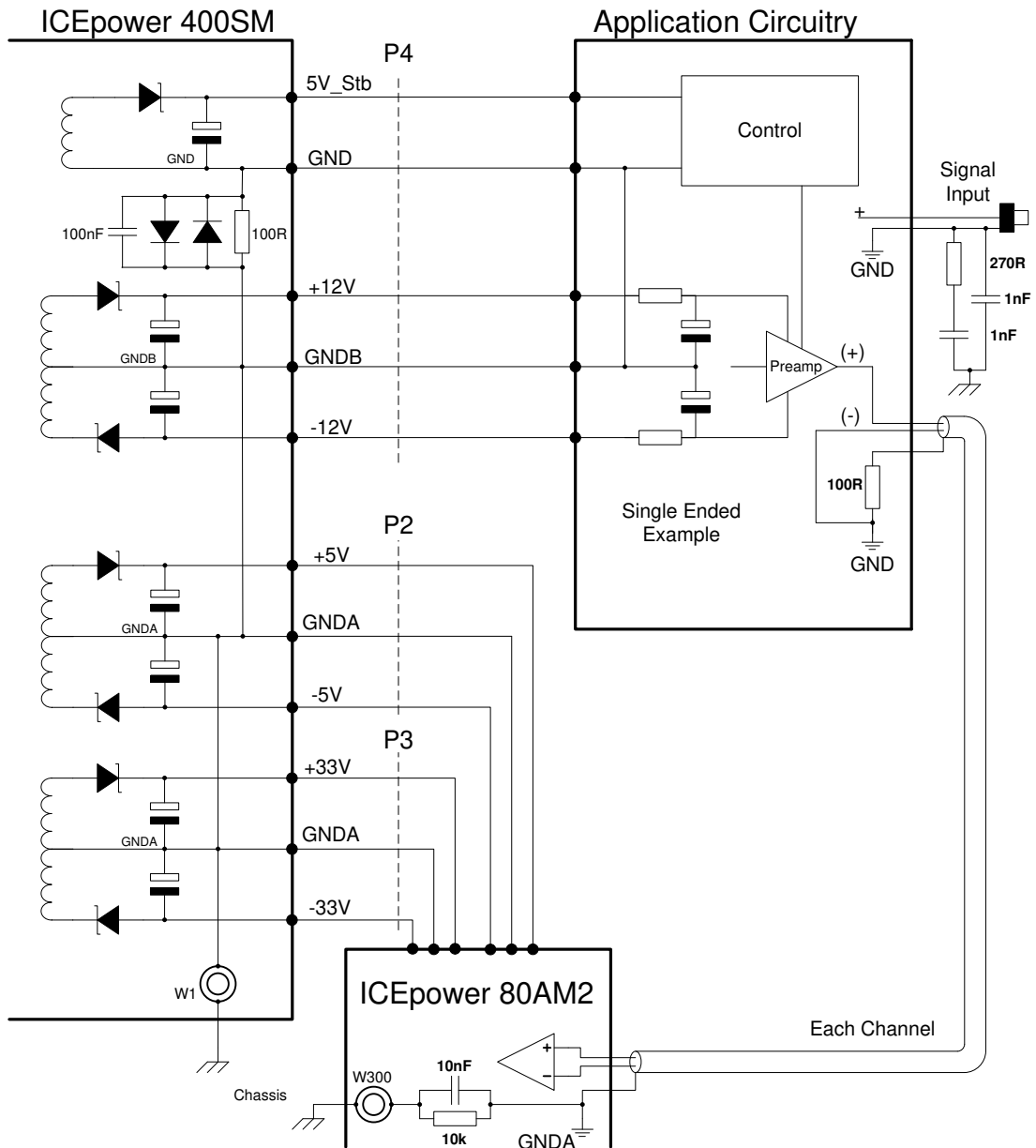

Figure 5: Grounding and external circuitry with suggested EMI filtering at the signal input

### CA\_Vclip\_mon

The CA\_Vclip\_mon monitor output provides a non-buffered replica of the internal protection bus signal with an output impedance of 10kOhm. Hereby the signal level desired for the application can be implemented by selecting the value of a single resistor as shown in

Figure 6. If the signal is used for driving other circuits, ensure that a buffer is used. For further description of the Vclip protection bus, see the

Protection Features' section.

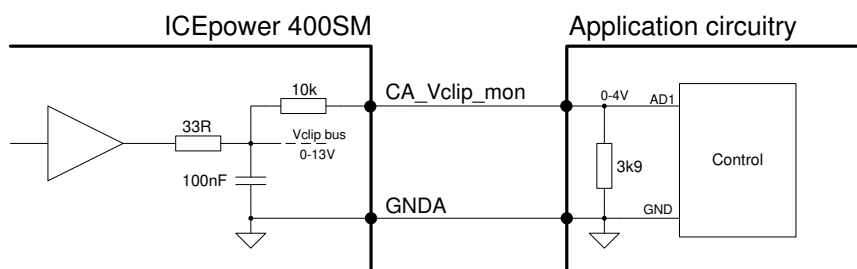

Figure 6: Monitor output and suggested application

LED\_prog

For easy implementation of visual indicators, the ICEpower400SM features an onboard programmable current LED-driver with 2 different display modes for indication of on-mode and standby-mode.

The current programming of the LEDs is done by applying a resistor between the LED\_prog pin and GND or 5V\_Stb as illustrated in Figure 7. If resistor values lower than 3k9 is connected between LED\_prog and 5V\_Stb the LED will turn off.

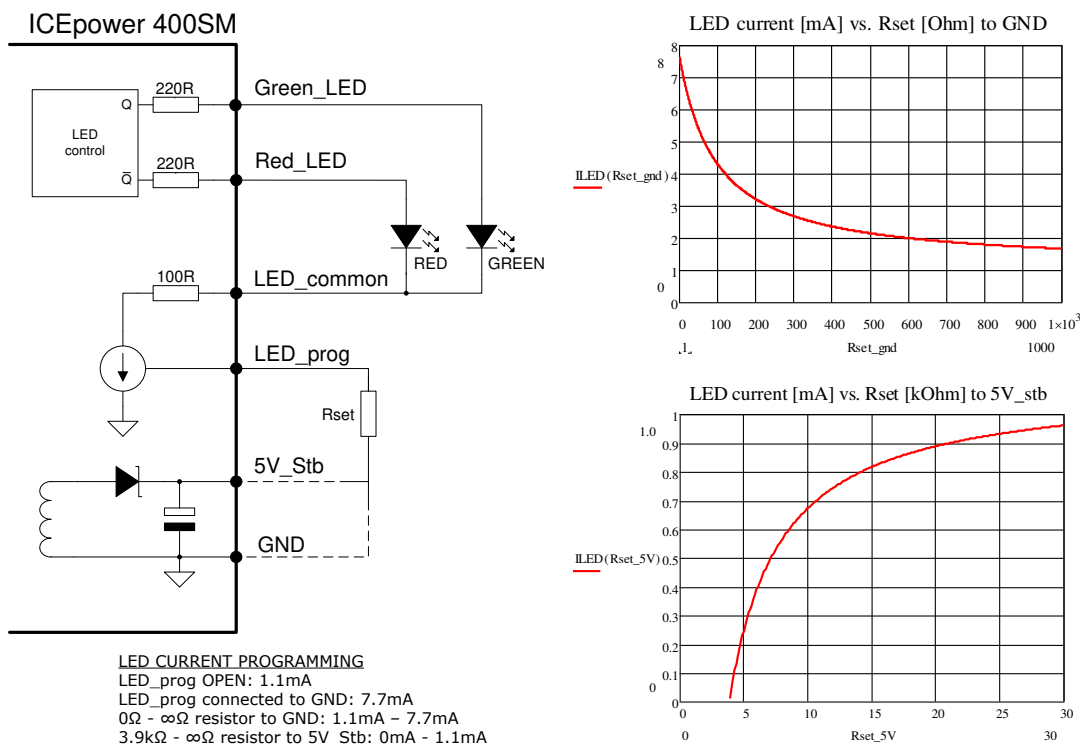

Figure 7: Application of the current programmable LED driver

On/off control (12V trigger, 3-5V trigger and Signal\_Sense)

Through the onboard 5V standby converter the ICEpower400SM can be powered on and off externally by using the two signals 12V trigger and 3-5V trigger. A Signal\_Sense function is also provided which automatically can switch on the ICEpower400SM in the event of an audio signal and switch off the ICEpower400SM to enter standby mode when no audio signal has been present on the signal terminals for approximately 13 minutes.

The Signal sense function consists of an audio detection circuit and a timer. If an audio signal of more than typically 1.3 mV is present on the Signal\_Sense terminals, the main SMPS will always be in the On mode, unless the 12V and 3-5V triggers are both high. If none of the two triggers are high and audio is not present at the terminals the timer will switch off the SMPS after 13 minutes.

Together the 12V and the 3-5V triggers perform a logic Exclusive Or function, which enables the designer to force the module off with logic signals, also when the Signal\_Sense function is used. See Table 12 for on/off control truth table.

When changing control signals from on mode to standby mode, there is a 200ms delay before the main SMPS turns off. This is to provide time for circuitry connected to 5V\_Stb to power down in order to meet the standby mode current draw requirements.

Signal on Signal_Sense within last 13 minutes	12V trigger	3-5V trigger	Mode
X	H	H	Standby
NO	L	L	Standby
YES	L	L	ON
X	L	H	ON
X	H	L	ON

Table 12: On/Off truth table



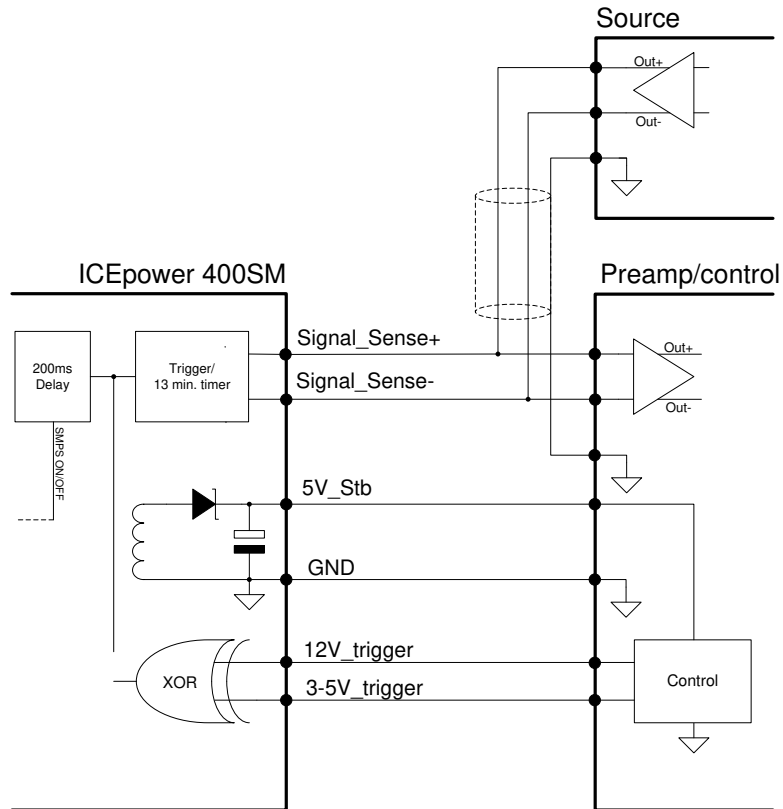

Figure 8: Typical application with Signal\_Sense function in fully balanced configuration

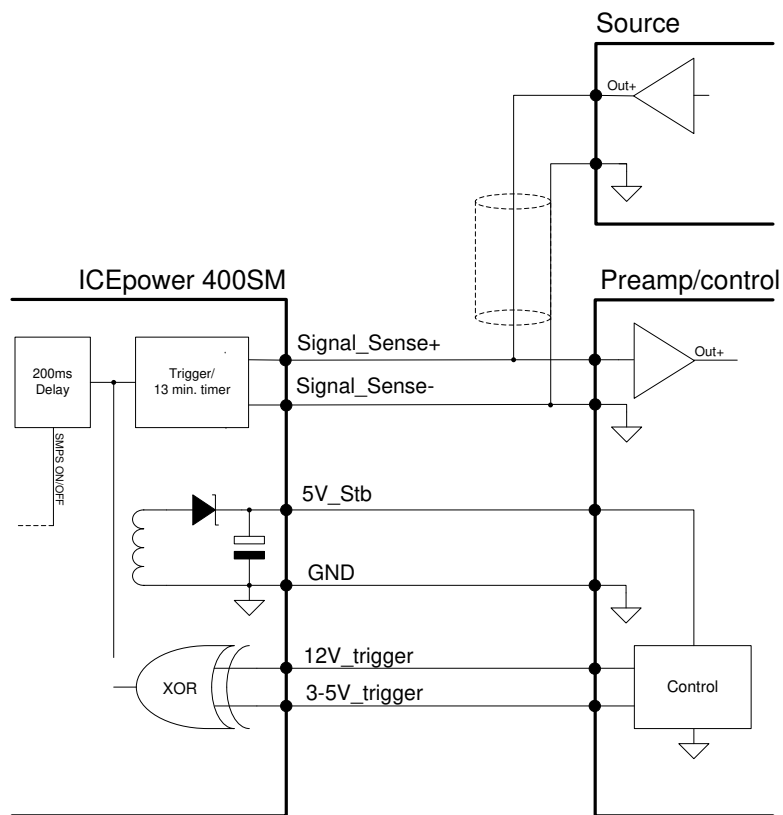

Figure 9: Typical application with Signal\_Sense function in single ended configuration

## Protection Features

### Main Converter

The Main Converter is equipped with six protection sensors which can either reduce the audio peak power level or switch off the Main Converter as a last resort against unrecoverable errors. Please see Figure 2: ICEpower400SM Block Diagram for connection of the protection sensors. Five of the six protection sensors act through a common amplifier peak clipper circuit in order to limit the peak power draw to a safe level and thus keep the system playing the music signal. In the event that the peak power reduction is not sufficient for the circuits to operate within safe limits a forced switch off is initiated. After an off period of approximately 9 seconds the Main Converter will start again. The last protection sensor will in the event of an error switch off the Main Converter for 9 seconds after which it will start again. Hence all protection circuits have an inherent self-recovery feature so no user interaction is needed.

### Primary Heatsink Thermal Protection

The temperature of the primary side heatsink is monitored constantly and in the event that the temperature limit is exceeded the common amplifier clip circuit is gradually activated to keep the music signal playing.

### Secondary Heatsink Thermal Protection

The temperature of the secondary side heatsink is monitored constantly and in the event that the temperature limit is exceeded, the common amplifier clip circuit is gradually activated to keep the music signal playing.

### Average Current Protection

The Main Converter output current is monitored and the average current is calculated. In the event that the average current has been too high for a safely defined time, the common amplifier clip circuit is gradually activated to keep the music signal playing.

### VD and VS Overload

In the event that one or both of the power rails for the amplifier bus, VD and VS, is overloaded and either of the voltages drops below a safe limit the common amplifier clip circuit is gradually activated to keep the music signal playing.

### Amplifier DC Protection

In the event that a DC is detected on the output of any amplifier it is assumed that the amplifier is defective and the Main Converter will be switched off immediately. After a period of time the Main Converter will automatically be switched on and if the DC voltage still is detected it will be switched off again and thus go into a cyclical on/off operation.

### Auxiliary Converter

The Auxiliary Converter generates the following supply voltages.

- $\pm 12V$  for a pre-amplifier or other auxiliary circuits requiring this level of supply voltage.
- $\pm 5V$  BUS for the connected ICEpower80AM2 amplifiers. Note: This voltage should not be used for any other purpose.
- Vdrive BUS for the connected ICEpower80AM2 amplifiers MOSFET drive circuits. Note: This voltage should not be used for any other purpose.

As the ICEpower80AM2 Class D amplifiers are of the single ended out type, supply pump cancellation is needed to avoid the need for huge decoupling capacitors. This supply pump cancellation action is performed by the Auxiliary Converter.

### Thermal Protection

The temperature of the Auxiliary Converter power devices is constantly monitored and in the event that their temperature reaches the maximum safe limit, the common amplifier clip circuit is gradually activated to keep the music signal playing.

### Supply Pump Canceler Overload Protection

The pump cancellation current is constantly monitored and in the event that the current reaches the maximum safe limit the common amplifier clip circuit is gradually activated to keep the music signal playing.

### ±12V Output Short Circuit Protection

The output current of the ±12V auxiliary voltages are constantly monitored and if the maximum allowable current is exceeded on either of the supply outputs the Auxiliary Converter is switched off for a short period of time after which it will restart. If the short circuit still exists the Auxiliary Converter will go into a cyclic protection mode to prevent damage of the circuits.

### Standby Converter

The Standby Converter has two operation modes with different power capability.

When in standby mode the converter operates in a low power consumption mode where it will be compliant with the 0.5W regulation while offering 250mW on its 5V output to auxiliary circuits. However, it will supply up to 1W in standby mode.

In full operation mode the Standby Converter can supply up to 5W on the 5V output.

### Overload

The Standby Converter is protected against overload conditions. In the event of a short circuit, the converter will switch off for a short period of time where after it will restart. If the short circuit is still present the converter will again switch off and thus keep the circuits within safe limits.

## Physical Dimensions

Note the location of pin 1 of all connectors. All dimensions are in mm.

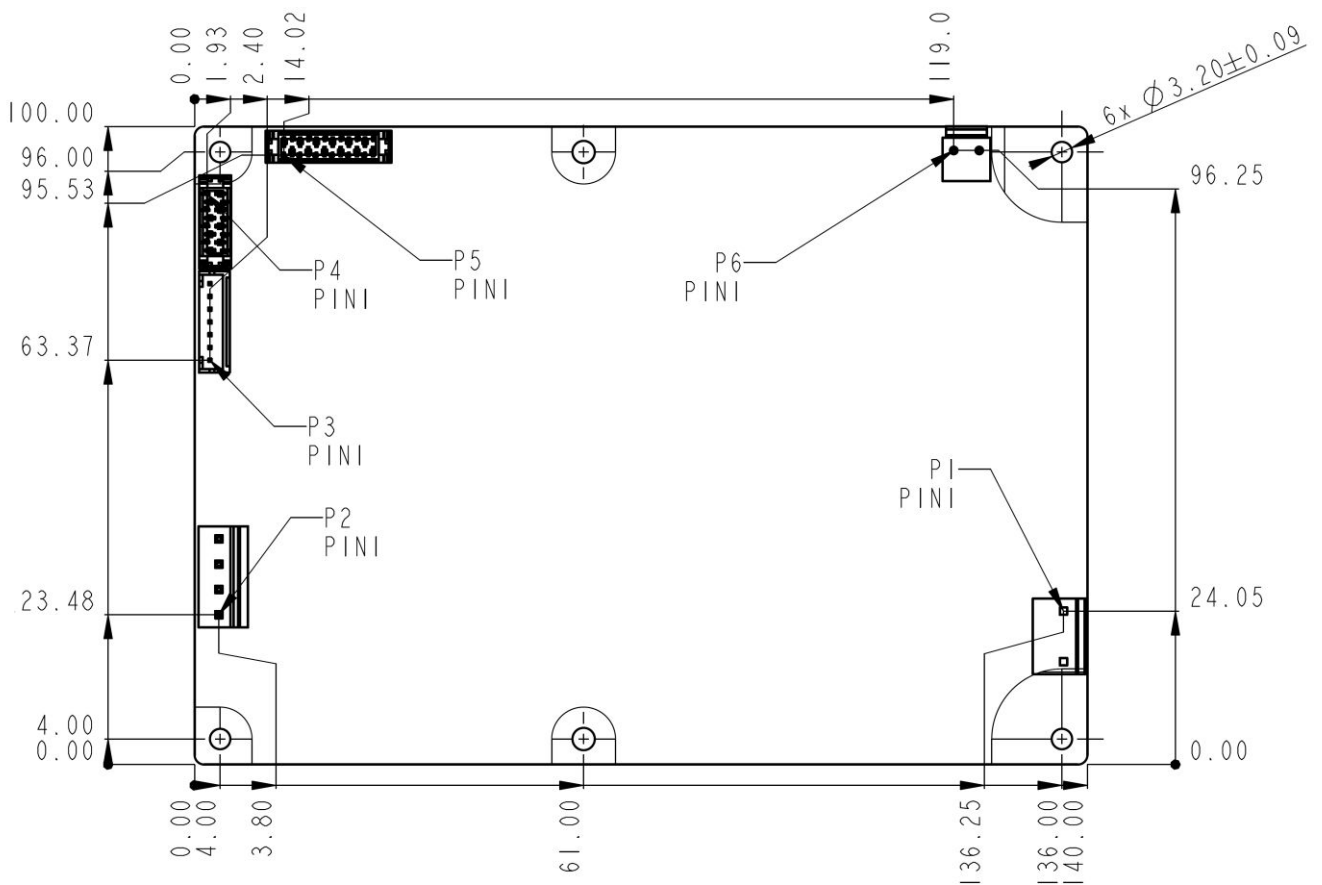

Figure 10: ICEpower400SM mechanical outline. Dimensions in mm.

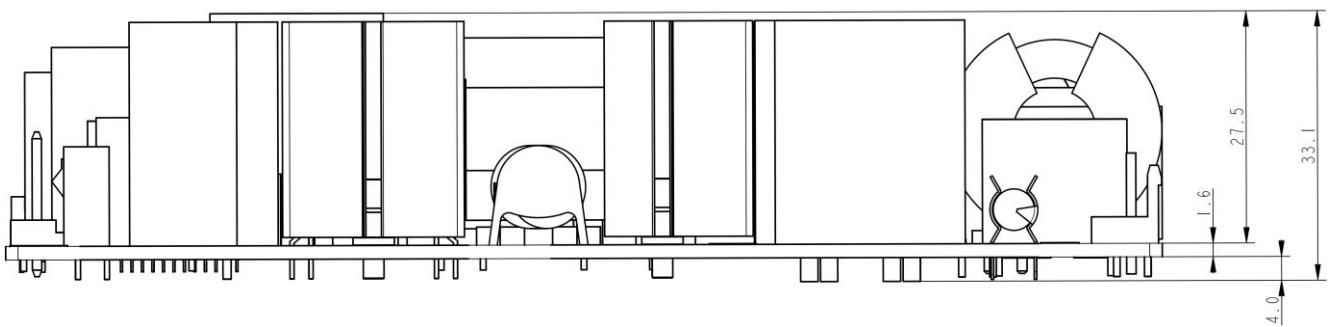

Figure 11: ICEpower400SM Side-view. Dimensions in mm.

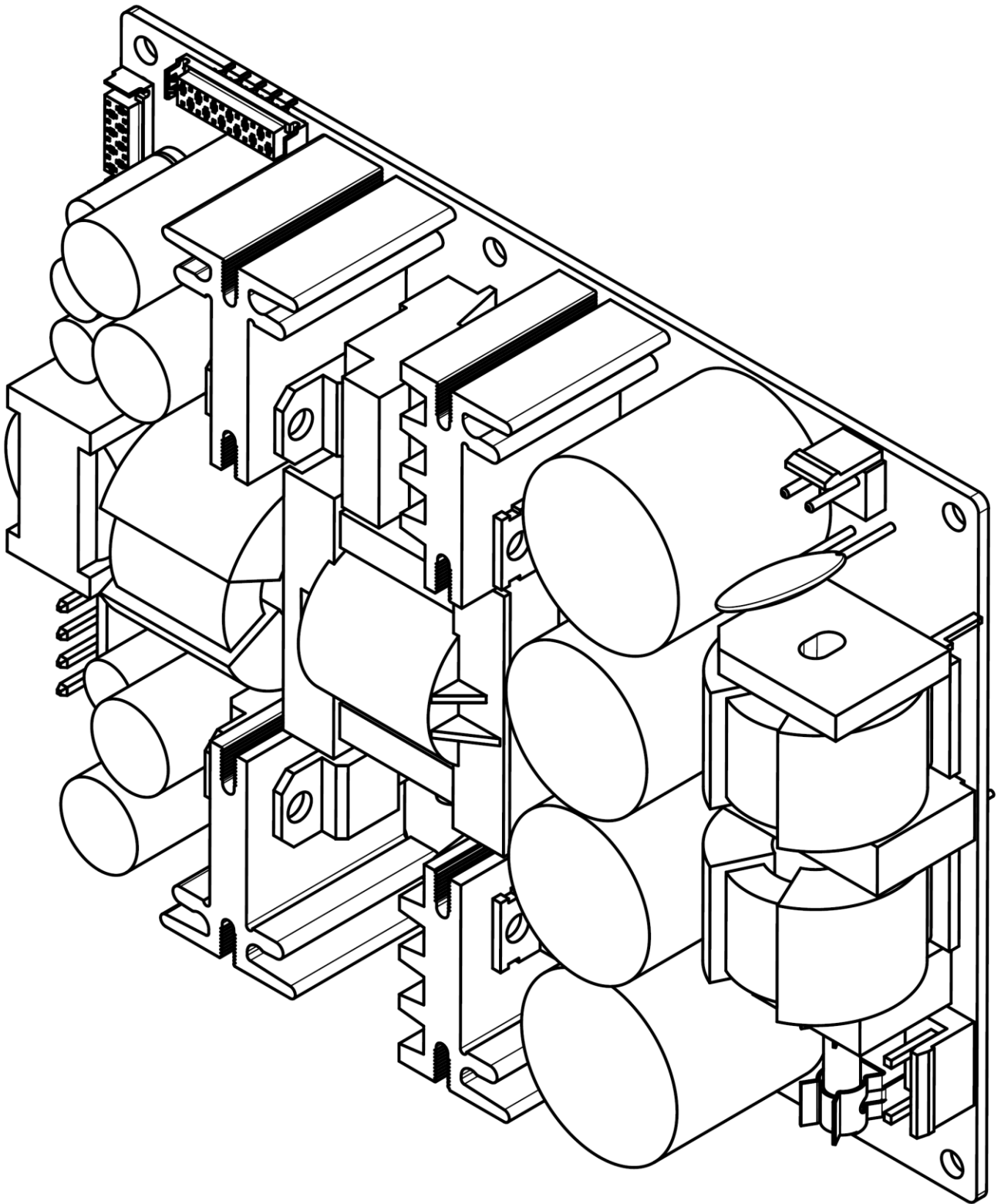

Figure 12: ICEpower400SM 3D-view

### Drill Pattern

All dimensions are in mm. The diameters of the mounting holes are 3.2 mm.

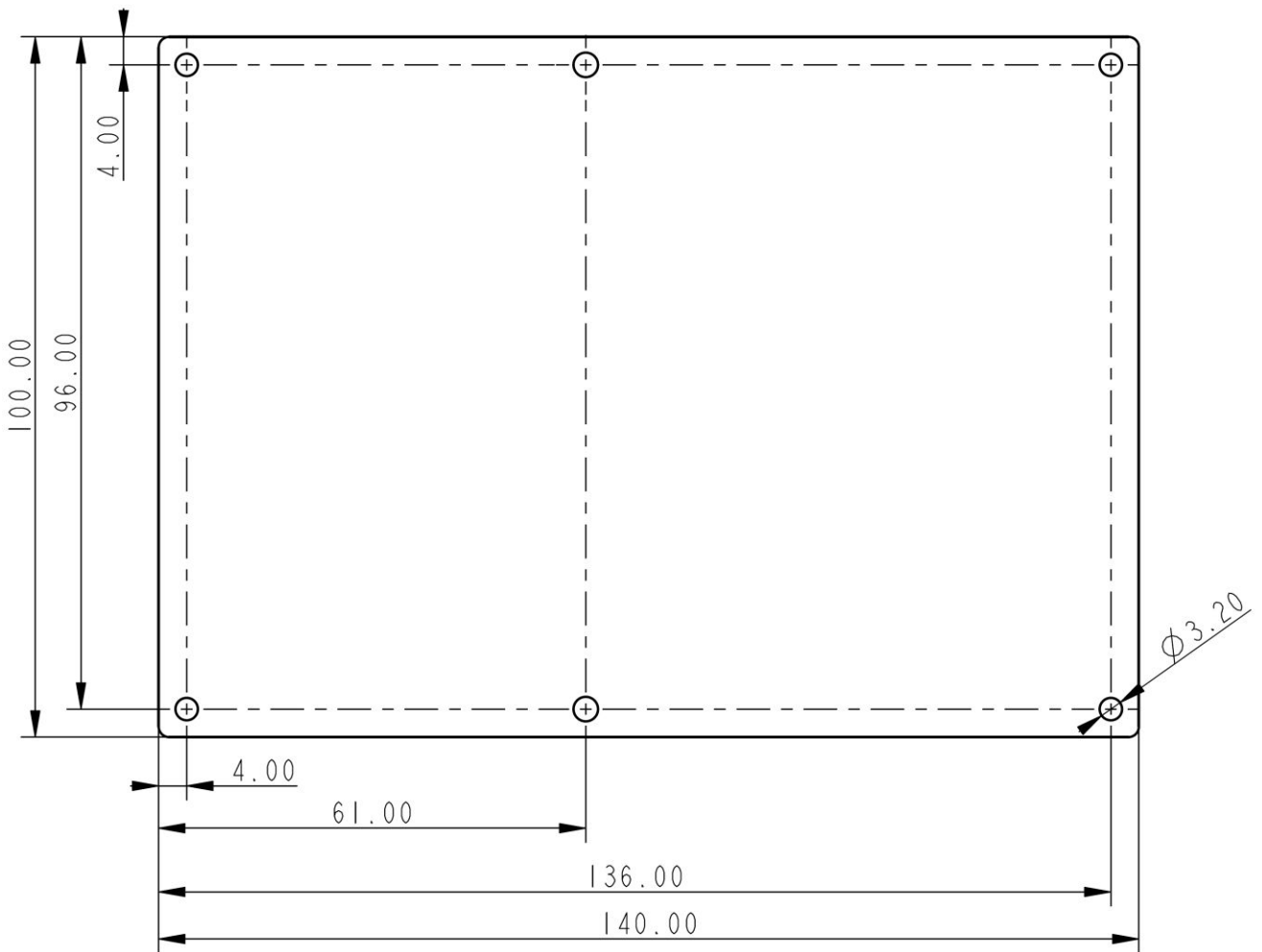

Figure 13: ICEpower400SM PCB drill pattern

# ICEpower80AM2

The ICEpower80AM2 is a two channel single ended output Class D audio amplifier utilizing ICEpower patented HCOM technology. Each channel comprises a high impedance fully balanced input buffer for high suppression of hum and noise in a multi-channel application. The two channel amplifier module can easily be bridged creating a single channel of higher output power by connecting the two balanced inputs in anti-phase and activating the BT sync input. The amplifier outputs are protected against overload as well as thermally protected.

The amplifier outputs are protected against overload as well as thermally protected.

The ICEpower80AM2 module is intended for driving two 4Ω loudspeakers or one 8Ω speaker in BTL mode. However, in BTL mode the amplifier will drive a 4 speaker, but the amplifier will heat up more quickly, thus the optimum speaker load impedance is 6 to 8 in BTL mode.

Important note: Ensure sufficient mechanical clearance and adequate ventilation for safe and proper operation.

## Block Diagram

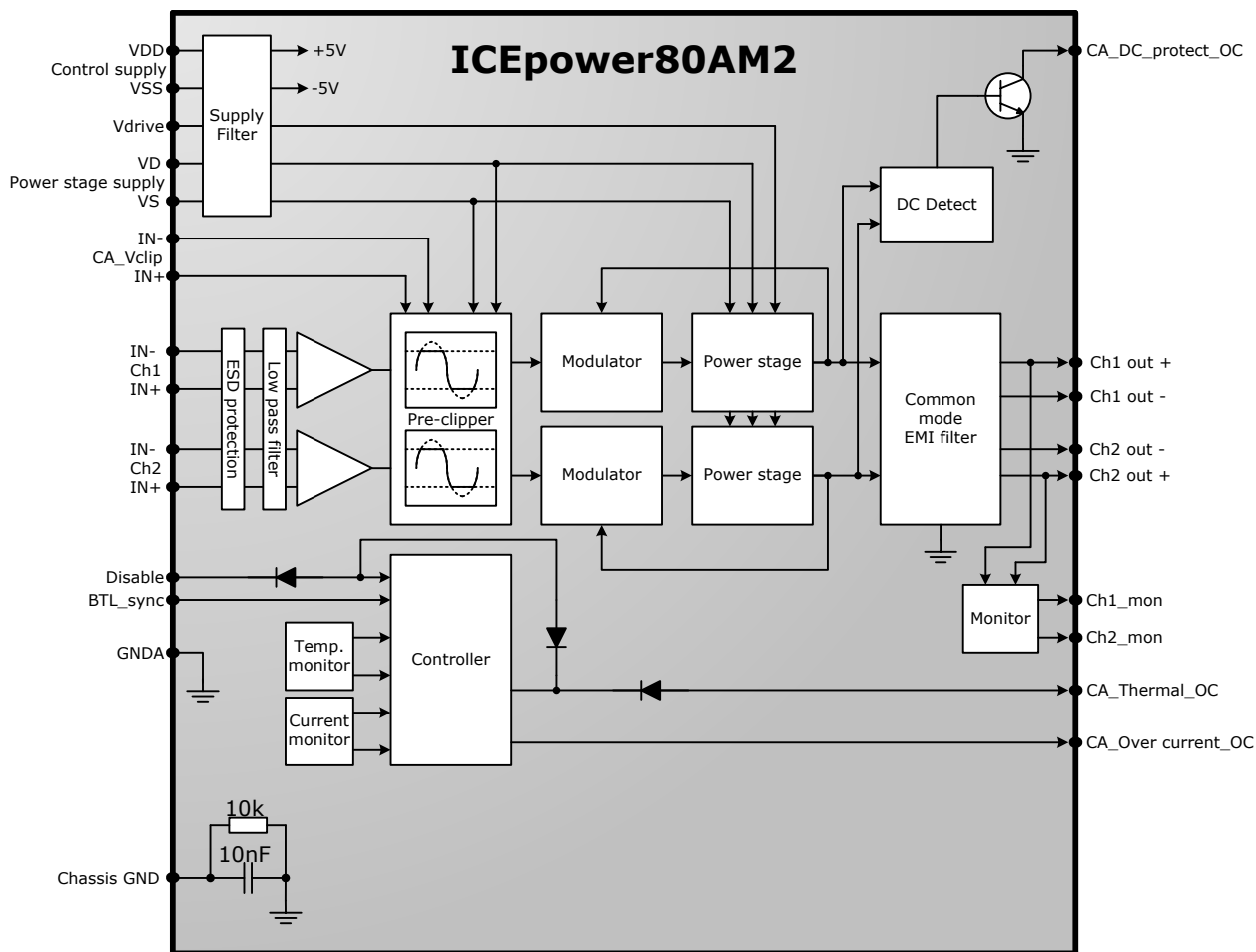

Figure 14: ICEpower80AM2 block diagram

## Absolute Maximum Ratings

Absolute maximum ratings indicate limits above which damage may occur.

### Amplifier Signal Input Section

Symbol	Parameter	Value	Unit
Vin+, Vin-	Maximum input voltage range <sup>1)</sup>	±12	V <sub>peak</sub>
Vin+ - Vin-	Maximum differential DC-voltage on input for specified performance <sup>1)+2)</sup>	±0.5	V

Table 13: Absolute maximum ratings, Amplifier input section

<sup>1)</sup> Both channels

<sup>2)</sup> In case of large differential offset, amplifier enable should be delayed to avoid pop sound.

### Power Supply Section

Symbol	Parameter	Value	Unit
VD, VS	Maximum voltage range on pin <sup>1)</sup>	±36	V
Vdrive	Maximum voltage range on pin <sup>2)</sup>	VS+14V	V
VDD,VSS	Maximum voltage range on pin <sup>3)</sup>	±5.5	V

Table 14: Absolute maximum ratings, Power supply section

<sup>1)</sup> Common supply for power stage (VD positive, VS negative), exceeding the specified value may damage the module

<sup>2)</sup> Drive voltage for half bridge stage, exceeding the specified value may damage the module

<sup>3)</sup> Common supply for control and analogue circuits (VDD positive, VSS negative), exceeding the specified value may damage the module

### Control Pin Section

Symbol	Parameter	Value	Unit
Disable	Minimum voltage <sup>1)</sup>	-0.3	V
BTL_sync	Minimum voltage <sup>1)</sup>	-0.3	V

Table 15: Absolute maximum ratings, control pin section

<sup>1)</sup> These pins should never be pulled high, only pull down is allowed. Use open collector type circuit for control.

### Output Section

Symbol	Parameter	Value	Unit
CL <sub>SE</sub>	Maximum purely capacitive load <sup>1)</sup>	390	nF
CL <sub>BTL</sub>	Maximum purely capacitive load <sup>1)</sup>	220	nF
RL <sub>SE</sub>	Minimum load <sup>1)</sup>	3	Ω
RL <sub>BTL</sub>	Minimum load <sup>1)</sup>	6	Ω

Table 16: Absolute maximum ratings, Output section

<sup>1)</sup> Protection circuits will act to protect the amplifier.



## Thermal Specifications

Unless otherwise specified.  $T_a=25^\circ\text{C}$ ,  $f=1\text{kHz}$ ,  $R_L=4\Omega$ , Supplied from ICEpower400SM

Symbol	Parameter	Conditions	Min	Typ	Max	Units
$t_{Pmax}$	Time of maximum output power Limited by ICEpower80AM2	2 x 80W 1 x ICEpower80AM2, 4 $\Omega$ SE	-	60	-	s
$t_{Pmax}$	Time of maximum output power Limited by ICEpower80AM2	1 x 160W 1 x ICEpower80AM2, 8 $\Omega$ BTL	-	60	-	s
$P_T$	Continuous amplifier output power per channel without thermal shutdown. Limited by ICEpower80AM2	Thermal stab. @ $T_a = 25^\circ\text{C}$ 2 channels driven 1 x ICEpower80AM2, 4 $\Omega$ SE	-	2x20	-	W
$P_T$	Continuous amplifier output power without thermal shutdown. Limited by ICEpower80AM2	Thermal stab. @ $T_a = 25^\circ\text{C}$ . 1 x ICEpower80AM2, 8 $\Omega$ BTL	-	1x40	-	W

Table 17: Thermal Specifications ICEpower80AM2

## General Audio Specifications (SE mode)

Unless otherwise specified,  $T_a=25^{\circ}\text{C}$ , Supplied by ICEpower400SM @ 230VAC mains

Symbol	Parameter	Conditions	Min	Typ	Max	Units
$P_o$	Output power @ 0.1%THD+N 20Hz < f < 20kHz <sup>1)</sup>	$R_L = 4\Omega$ SE, 1 Channel	-	80	-	W
$P_o$	Output power @ 0.1%THD+N 20Hz < f < 20kHz <sup>1)</sup>	$R_L = 4\Omega$ SE, 2 Channels	-	80	-	W
$P_o$	Output power @ 0.1%THD+N 20Hz < f < 20kHz <sup>1)</sup>	$R_L = 4\Omega$ SE, 8 Channels	-	50	-	W
$P_o$	Output power @ 0.1%THD+N 20Hz < f < 20kHz <sup>1)</sup>	$R_L = 4\Omega$ SE, 16 Channels	-	25	-	W
$P_o$	Output power @ 1%THD+N f = 1kHz <sup>1)</sup>	$R_L = 4\Omega$ SE, 1 Channel	-	100	-	W
$P_o$	Output power @ 10%THD+N f = 1kHz <sup>1)</sup>	$R_L = 4\Omega$ SE, 1 Channel	-	130	-	W
$V_{o-max}$	Max output voltage	$R_L = 4\Omega$	-	28	-	$V_p$
$I_{o-max}$	Max output current	(output current limited)	-	20	-	$A_p$
THD+N	Total Harmonic Distortion plus Noise <sup>1)</sup>	4 $\Omega$ SE, f = 100Hz, $P_o=1W$	-	0.003	-	%
$V_{N,O}$	Output referenced idle noise	A-weighted Un-weighted, BW=20kHz	- -	45 60	- -	$\mu\text{V}$
$A_v$	Nominal voltage gain relative to differential input voltage	f = 1 kHz, SE	-	25.8	-	dB
$f_r$	Frequency response 10Hz – 20kHz	4 $\Omega$ , 8 $\Omega$ , Open load	-	$\pm 0.4$	-	dB
$f_u$	Upper bandwidth limit, -3dB	$R_L = 8\Omega$ $R_L = 4\Omega$	- -	120 100	- -	kHz kHz
$f_l$	Lower bandwidth limit, -3dB	$R_L = 4\Omega$ to open load	-	1.5	-	Hz
$f_p$	Full power bandwidth <sup>2)</sup>	80W, 4 $\Omega$ SE	15	-	-	kHz
$Z_o$	Output impedance magnitude	f $\leq$ 1kHz	-	42	-	m $\Omega$
DF	Damping Factor	f = 100Hz, 4 $\Omega$	-	95	-	
$Z_L$	Load impedance range		3.2	4	$\infty$	$\Omega$
D	Dynamic range	A-weighted, 80W, 4 $\Omega$	-	110	-	dB
IMD	Intermodulation (CCIF)	f = 18.5kHz, 1kHz $P_o = 10W$	-	0.0009	-	%
TIM	Transient intermodulation (DIM30)	$P_o = 10W$	-	0.0035	-	%

Table 18: General audio specifications

<sup>1)</sup> An Audio Precision AES17 20 kHz 7<sup>th</sup> order measurement filter is used for measurements. The frequency 6.67 kHz corresponds to the worst-case scenario where both 2<sup>nd</sup> and 3<sup>rd</sup> harmonics are within the audio band.

<sup>2)</sup> Full power bandwidth is limited by protection circuits. See Amplifier protections section.

## General Audio Specifications (BTL mode)

Unless otherwise specified,  $T_a=25^{\circ}\text{C}$ , Supplied by ICEpower400SM @ 230VAC mains

Symbol	Parameter	Conditions	Min	Typ	Max	Units
$P_o$	Output power @ 0.1%THD+N 20Hz < f < 20kHz <sup>1) 2)</sup>	$R_L = 8\Omega$ BTL, 1Ch.	-	1 x 160	-	W
$P_o$	Output power @ 0.1%THD+N 20Hz < f < 20kHz <sup>1) 2)</sup>	$R_L = 8\Omega$ BTL, 2Ch.	-	2 x 160	-	W
$P_o$	Output power @ 0.1%THD+N 20Hz < f < 20kHz <sup>1) 2)</sup>	$R_L = 8\Omega$ BTL, 8Ch.	-	8 x 50	-	W
$P_o$	Output power @ 1%THD+N f = 1kHz <sup>1)</sup>	$R_L = 8\Omega$ BTL, 1Ch.	-	1 x 200	-	W
$V_{o-max}$	Max output voltage	$R_L = 8\Omega$	-	56	-	$V_p$
$I_{o-max}$	Max output current	(output current limited)	-	20	-	$A_p$
THD+N	Total Harmonic Distortion plus Noise <sup>1)</sup>	$8\Omega$ BTL, f = 100Hz, $P_o = 1W$	-	0.003	-	%
$V_{N,O}$	Output referenced idle noise	A-weighted Un-weighted, BW=20kHz	- -	60 75	- -	$\mu\text{V}$
$A_v$	Nominal voltage gain relative to differential input voltage	f = 1 kHz, BTL	-	31.8	-	dB
f	Frequency response	10Hz – 20kHz, All loads	-	$\pm 0.4$	-	dB
$f_u$	Upper bandwidth limit	$R_L = 8\Omega$ , -3dB	-	100	-	kHz
$f_l$	Lower bandwidth limit	$R_L =$ All loads, -3dB	-	1.3	-	Hz
$f_p$	Full power bandwidth <sup>2)</sup>	160W, $8\Omega$ BTL	15	-	-	kHz
$Z_o$	Output impedance magnitude	f $\leq$ 1kHz	-	45	-	$m\Omega$
DF	Damping Factor	f = 100Hz, $8\Omega$	-	177	-	
$Z_L$	Load impedance range		6.4	8	$\infty$	$\Omega$
D	Dynamic range	A-weighted, 160W, $8\Omega$	-	115	-	dB
IMD	Intermodulation (CCIF)	f = 18.5kHz, 1kHz $P_o = 10W$	-	0.0002	-	%
TIM	Transient intermodulation (DIM30)	$P_o = 10W$	-	0.0035	-	%

Table 19: General audio specifications

<sup>1)</sup> An Audio Precision AES17 20 kHz 7<sup>th</sup> order measurement filter is used for measurements. The frequency 6.67 kHz corresponds to the worst-case scenario where both 2<sup>nd</sup> and 3<sup>rd</sup> harmonics are within the audio band.

<sup>2)</sup> Full power bandwidth is limited by protection circuits. See Amplifier protections section.

## Electrical Specifications

Unless otherwise specified,  $T_a=25^\circ\text{C}$ .

Symbol	Parameter	Conditions	Min	Typ	Max	Unit
$f_{o.1}$	Switching frequency channel 1	SE Idle channel 1	-	550	-	kHz
$f_{o.2}$	Switching frequency channel 2	SE Idle channel 2	-	480	-	kHz
$f_{o.BTL}$	Switching frequency BTL when synced	BTL Idle	-	520	-	kHz
$V_{ripple.1}$	Output ripple at $f_{g,}$ channel 1	SE Idle channel 1	-	1.3	-	Vrms
$V_{ripple.2}$	Output ripple at $f_{g,}$ channel 2	SE Idle channel 2	-	0.9	-	Vrms
$V_{ripple.BTL}$	Output ripple at $f_{g,}$ BTL	BTL Idle	-	0.3	-	Vrms
$f_s$	Amplifier switching frequency range	Idle to full scale	150	-	600	kHz
$R_i$	Input impedance, IN+ and IN-	Input to signal GND		47		$k\Omega$
$R_o$	Recommended signal source output impedance		-	100	1000	$\Omega$
$V_{offset.SE}$	DC offset on speaker outputs	Idle SE	-15	-	15	mV
$V_{offset.BTL}$	DC offset on speaker outputs	Idle BTL	-30	-	30	mV

Table 20: Electrical specifications

## Typical Performance Characteristics – Single Ended Mode

### Frequency Response

Conditions: Measurement bandwidth 500kHz,  $V_o=2V_{rms}$  ( $1W_{rms}@4\Omega$ )

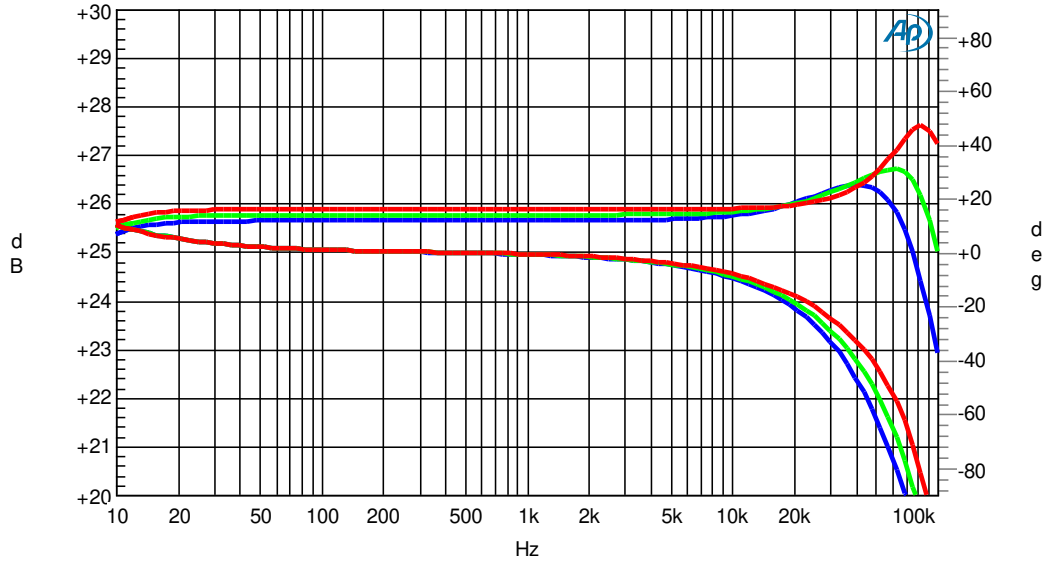

Figure 15: Frequency response in 4Ω (blue), 8Ω (green) and open load (red). Top – amplitude. Bottom – phase.

### Total Harmonic Distortion + Noise

Conditions: All channels enabled, one channel driven. Audio Precision AUX-0025 passive class-D filter and Audio Precision AES17 20 kHz 7<sup>th</sup> order measurement filter are used for measurements. The frequency 6.67 kHz corresponds to the worst-case scenario where both 2<sup>nd</sup> and 3<sup>rd</sup> harmonics are within the audio band.

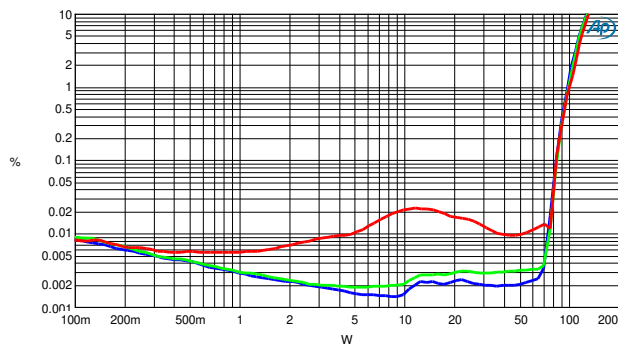

Figure 16: Ch1 THD+N vs. Po @ 100Hz, 1kHz, 6.67kHz, RL=4Ω

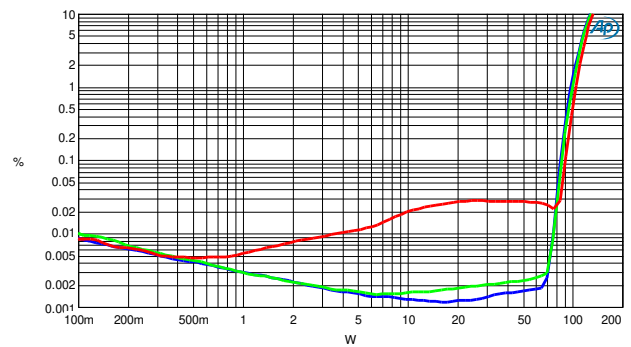

Figure 17: Ch2 THD+N vs. Po @ 100Hz, 1kHz, 6.67kHz, RL=4Ω

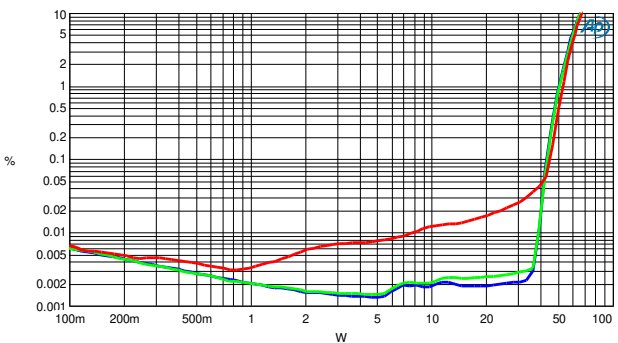

Figure 18: Ch1 THD+N vs. Po @ 100Hz, 1kHz, 6.67kHz, RL=8Ω

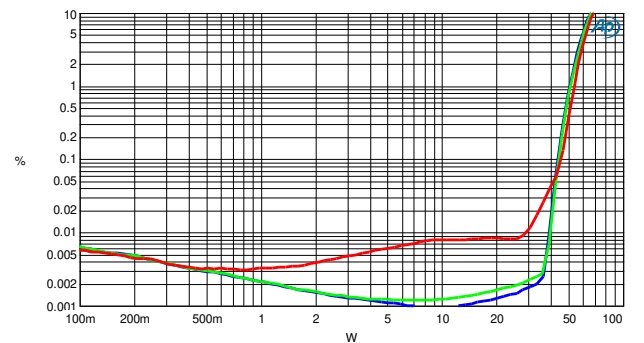

Figure 19: Ch2 THD+N vs. Po @ 100Hz, 1kHz, 6.67kHz, RL=8Ω

### Idle Noise and Low Power Spectrum

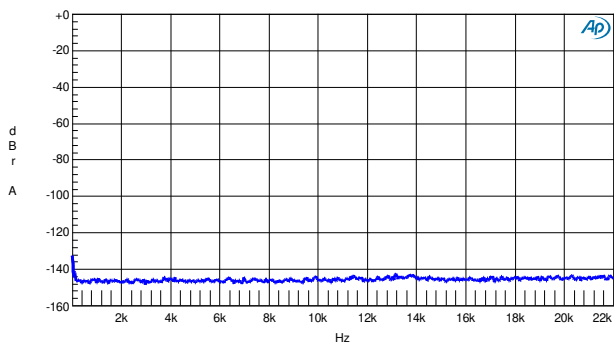

Figure 20: Ch1 Idle (16K FFT). Residual = 58µV(A), RL=4Ω (Relative to 80W into 4Ω)

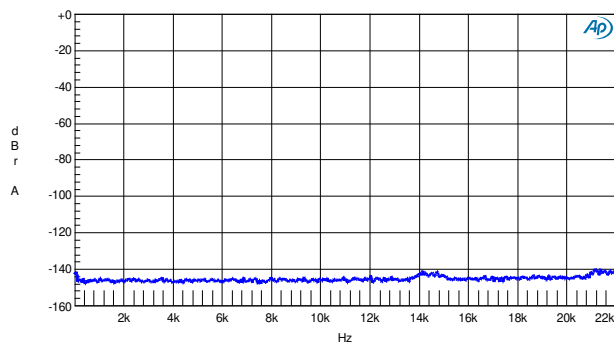

Figure 21: Ch2 Idle (16K FFT). Residual = 58µV(A), RL=4Ω (Relative to 80W into 4Ω)

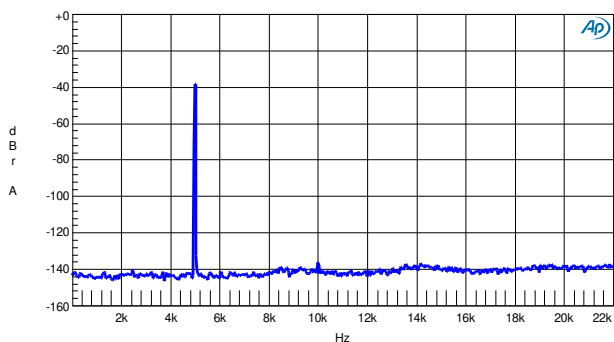

Figure 22: Ch1 FFT, 5kHz P<sub>o</sub>=100mW, RL=4Ω (Relative to 80W into 4Ω)

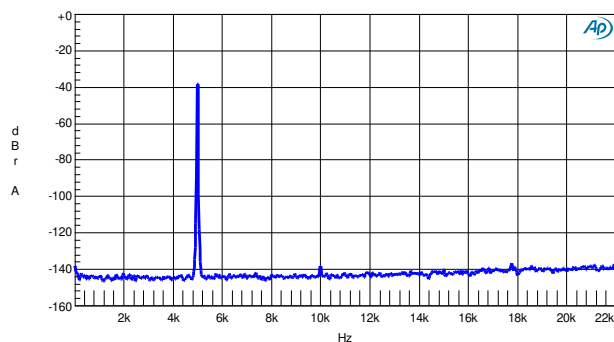

Figure 23: Ch2 FFT, 5kHz P<sub>o</sub>=100mW, RL=4Ω (Relative to 80W into 4Ω)

### Intermodulation Distortion

Conditions: Audio Precision AUX-0025 passive Class D filter

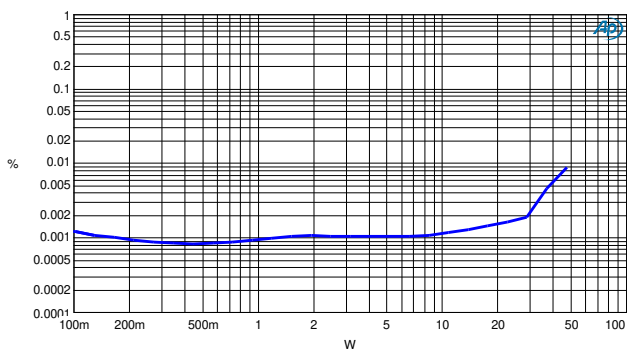

Figure 24: CCIF vs. P<sub>o</sub>, R<sub>L</sub>=4Ω, f<sub>1</sub>=18.5kHz, f<sub>2</sub>=1kHz<sup>1)</sup>

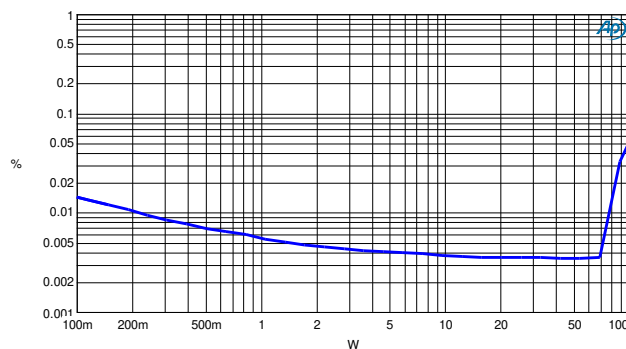

Figure 25: TIM(DIM30) vs. P<sub>o</sub>, R<sub>L</sub>=4Ω<sup>2)</sup>

<sup>1)</sup> The selected CCIF signal is equal amplitude 18kHz and 19kHz. The difference tone at 1kHz is detected.

<sup>2)</sup> DIM30 signal is a 3.15kHz square-wave, one-pole filtered at 30kHz, combined with a 15kHz sine-wave. P-P ratio 4:1. Detection: input is BP filtered with pass band [400Hz;2.45kHz]. 5<sup>th</sup> and 6<sup>th</sup> order IMD products will remain and will be detected.

## Typical Performance Characteristics – BTL Mode

### Frequency Response

Conditions: Measurement bandwidth 500kHz,  $V_o=2.82V_{rms}$  ( $1W_{rms}@8\Omega$ )

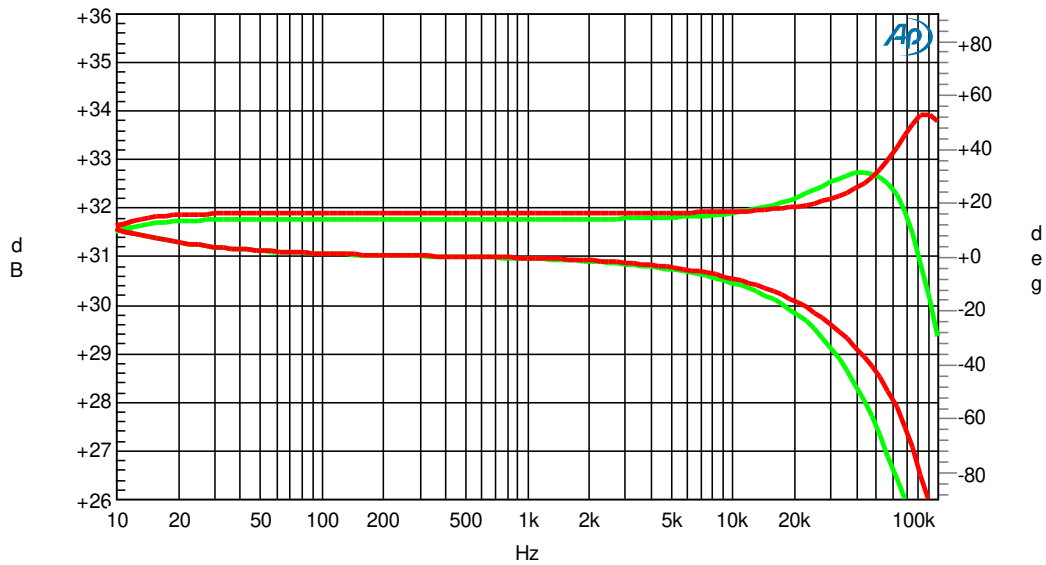

Figure 26: Frequency response in 8Ω (green) and open load (red). Top – amplitude. Bottom – phase.

### Total Harmonic Distortion + Noise, BTL

Conditions: All channels enabled, one channel driven. Audio Precision AUX-0025 passive class-D filter and Audio Precision AES17 20 kHz 7<sup>th</sup> order measurement filter are used for measurements. The frequency 6.67 kHz corresponds to the worst-case scenario where both 2<sup>nd</sup> and 3<sup>rd</sup> harmonics are within the audio band.

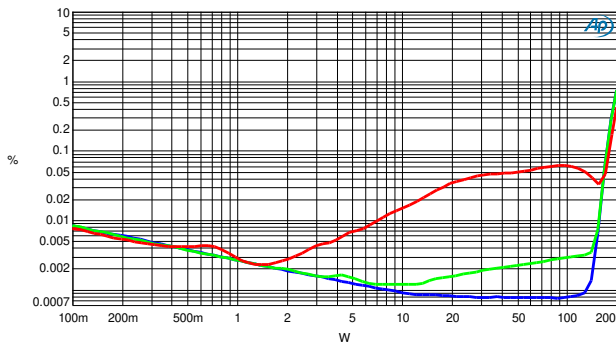

Figure 27: THD+N vs.  $P_o$  at 100Hz, 1kHz and 6.67kHz,  $R_L=8\Omega$

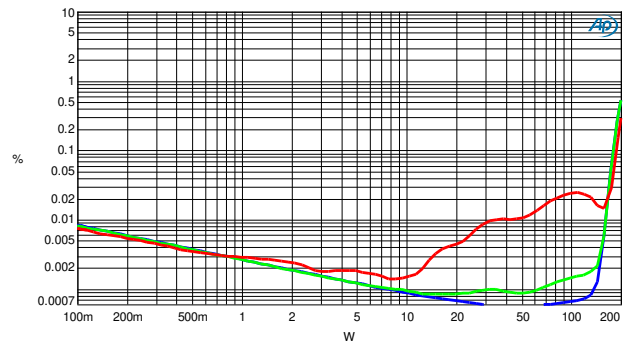

Figure 28: THD+N vs.  $P_o$  @ 100Hz, 1kHz & 6.67kHz  
Unloaded with reference to  $R_L = 8\Omega$

Idle Noise and Low Power Spectrum, BTL

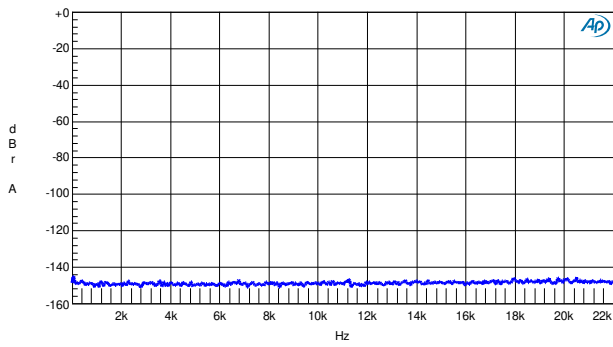

Figure 29: Idle (16K FFT). Residual = 58μV(A),  $R_L=8\Omega$   
(Relative to 160W into 8Ω)

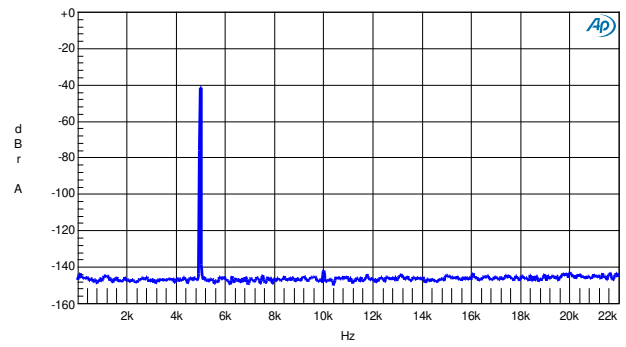

Figure 30: FFT, 5kHz  $P_o=100mW$ ,  $R_L=8\Omega$   
(Relative to 160W into 8 Ω)

Intermodulation Distortion, BTL

Conditions: Audio Precision AUX-0025 passive class-D filter

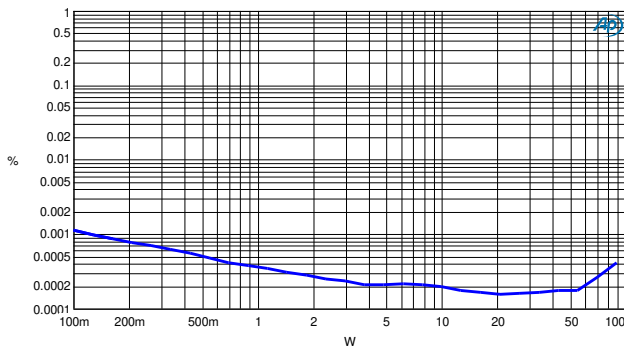

Figure 31: CCIF vs.  $P_o$ ,  $R_L=8\Omega$ ,  $f_1=18.5kHz$ ,  $f_2=1kHz$  <sup>1)</sup>

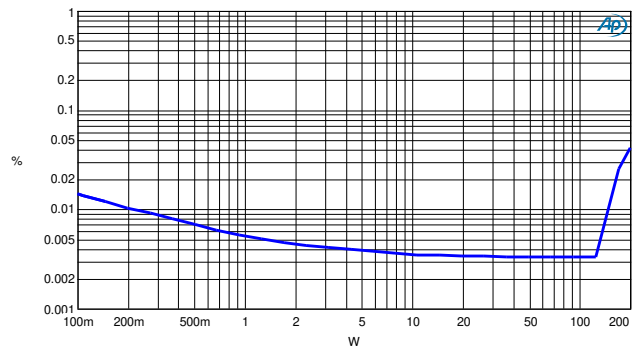

Figure 32: TIM(DIM30) vs.  $P_o$ ,  $R_L=8\Omega$  <sup>2)</sup>

<sup>1)</sup> The selected CCIF signal is equal amplitude 18KHz and 19KHz. The difference tone at 1KHz is detected.

<sup>2)</sup> DIM30 signal is a 3.15kHz square-wave, one-pole filtered at 30KHz, combined with a 15KHz sine-wave. P-P ratio 4:1. Detection: input is BP filtered with pass band [400Hz;2.45KHz]. 5<sup>th</sup> and 6<sup>th</sup> order IMD products will remain and will be detected.



## Typical Performance Characteristics – 16 Channel System – Single Ended Mode

### Total Harmonic Distortion + Noise: 1 to 16 channels driven

Conditions:  $R_L = 4\Omega$ , THD+N measured at one channel while the same input signal is applied in phase to 1 to 16 channels.

Audio Precision AUX-0025 passive class-D filter and Audio Precision AES17 20 kHz 7<sup>th</sup> order measurement filter are used for measurements.

Eight ICEpower80AM2 modules are active/enabled during all measurements, only input signal is switched. All powered by one ICEpower400SM.

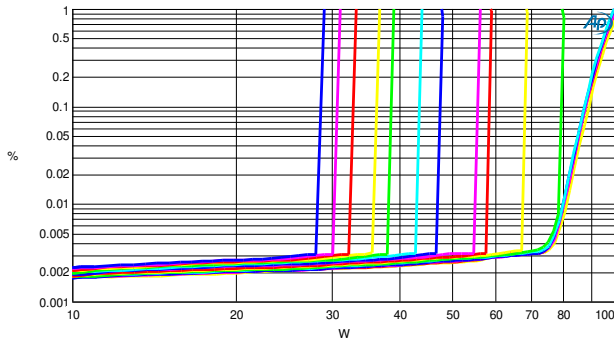

Figure 33: 230V AC 50Hz, THD+N vs. Po at 1kHz 1 to 16ch

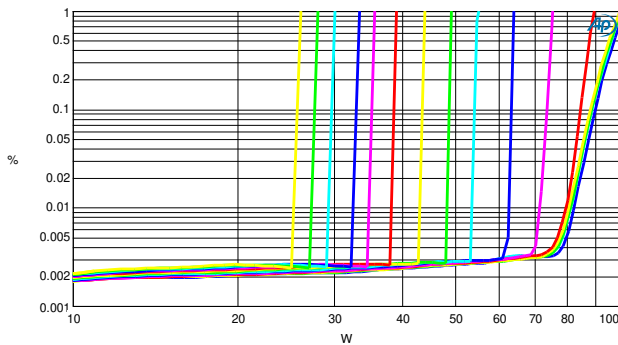

Figure 34: 115V AC 60Hz, THD+N vs. Po at 1kHz, 1 to 16ch

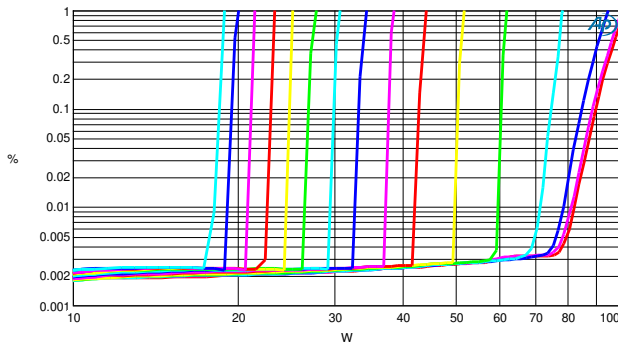

Figure 35: 100V AC 50Hz, THD+N vs. Po at 1kHz, 1 to 16ch

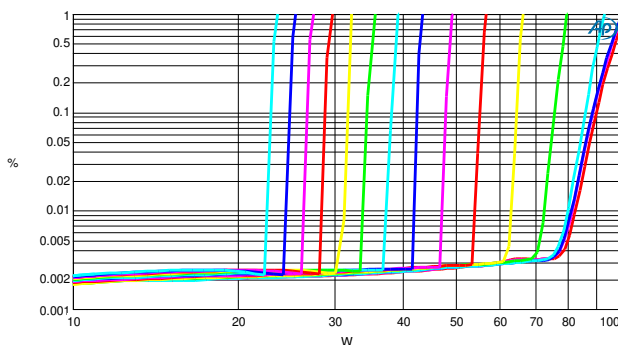

Figure 36: 100V AC 50Hz, THD+N vs. Po at 1kHz, 1 to 16ch  
With additional 390uF 400V on 400SM DC Bulk (P7)

## Cross Talk

Conditions:  $P_o=50W$   $R_L=4\Omega$ , wide bandwidth measurement. Audio Precision AUX-0025 passive class-D filter and Audio Precision AES17 20 kHz 7<sup>th</sup> order measurement filter are used for measurements.

Eight ICEpower80AM2 modules are active/enabled during all measurements, only input signal is switched.

16 channels all powered by one ICEpower400SM.

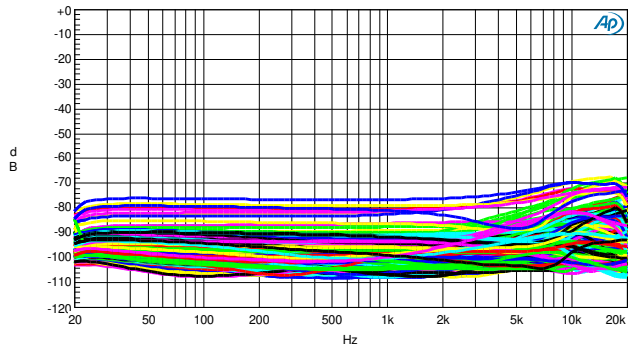

Figure 37: Cross talk, all channels versus all channels

## Typical Performance Characteristics – 8 Channel System – BTL Mode

### Total Harmonic Distortion + Noise: 1 to 8 channels driven

Conditions:  $R_L=8\Omega$ , THD+N measured at one BTL channel while the same input signal is applied in phase to 1 to 8 channels.

Audio Precision AUX-0025 passive class-D filter and Audio Precision AES17 20 kHz 7<sup>th</sup> order measurement filter are used for measurements.

Eight ICEpower80AM2 modules in BTL mode are active/enabled during all measurements, only input signal is switched.

All powered by one ICEpower400SM.

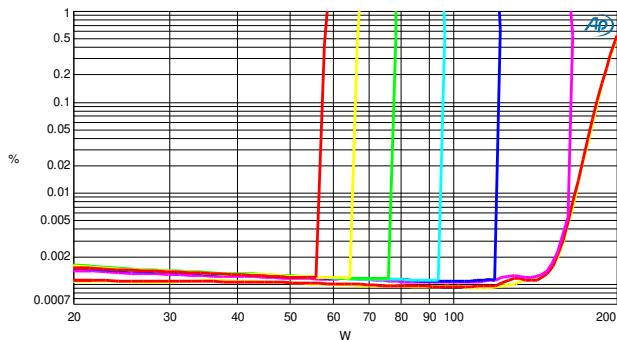

Figure 38: 230V AC 50Hz, THD+N vs. Po at 100Hz 1 to 8ch

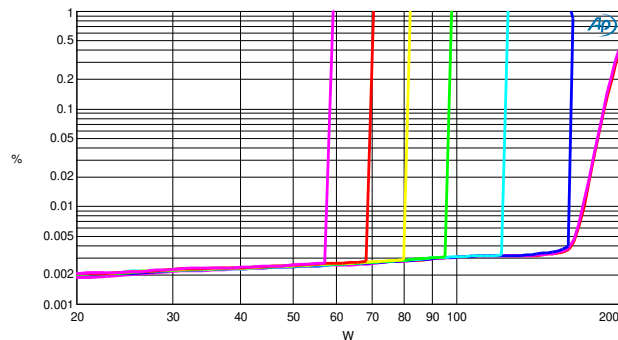

Figure 39: 230V AC 50Hz, THD+N vs. Po at 1kHz 1 to 8ch

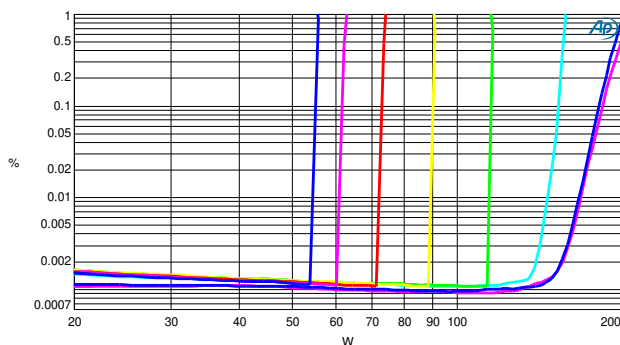

Figure 40: 115V AC 60Hz, THD+N vs. Po at 100Hz, 1 to 8ch

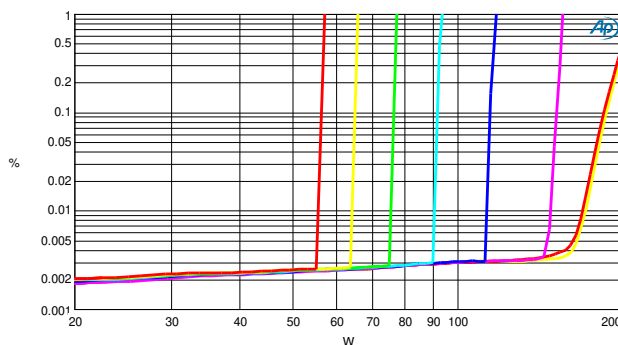

Figure 41: 115V AC 60Hz, THD+N vs. Po at 1kHz, 1 to 8ch

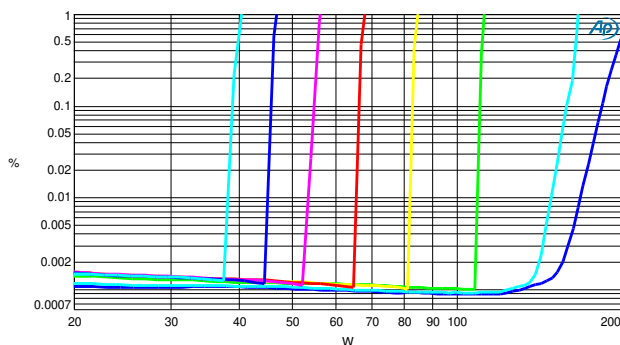

Figure 42: 100V AC 50Hz, THD+N vs. Po at 100Hz, 1 to 8ch

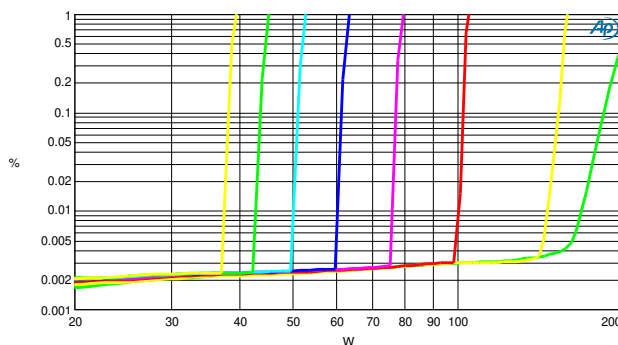

Figure 43: 100V AC 50Hz, THD+N vs. Po at 1kHz, 1 to 8ch

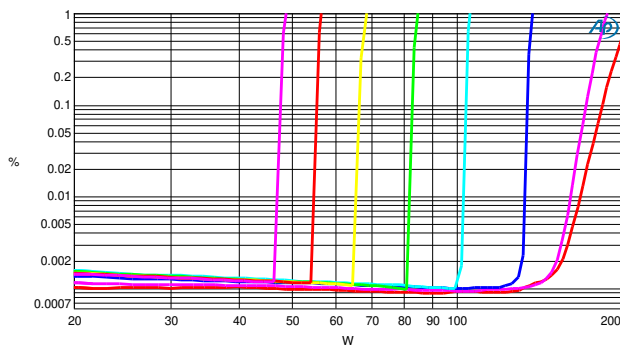

Figure 44: 100V AC 50Hz, THD+N vs. Po at 100Hz, 1 to 8ch

With adtional 390uF 400V on 400SM DC Bulk (P7)

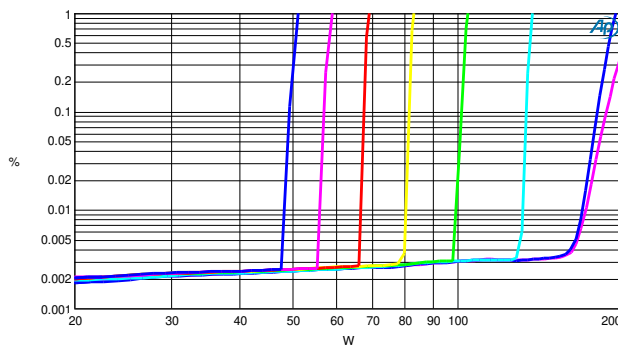

Figure 45: 100V AC 50Hz, THD+N vs. Po at 1kHz, 1 to 8ch

With adtional 390uF 400V on 400SM DC Bulk (P7)

## Cross Talk, BTL

Conditions:  $P_o=100W$   $R_L=8\Omega$ , wide bandwidth measurement. Audio Precision AUX-0025 passive class-D filter and Audio Precision AES17 20 kHz 7<sup>th</sup> order measurement filter are used for measurements.

Eight ICEpower80AM2 modules in BTL mode are active/enabled during all measurements, only input signal is switched.

8 channels all powered by one ICEpower400SM.

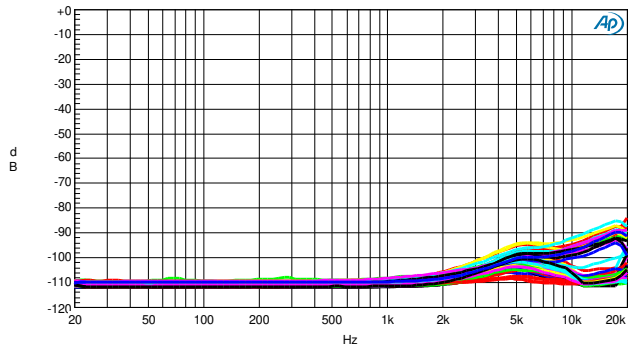

Figure 46: Cross talk, all channels versus all channels

## Output Impedance – Single Ended Mode

The output impedance is calculated from measured amplifier gain and phase, unloaded and  $1\Omega$  loaded. Output voltage is  $3.16V_{rms}@1kHz$  ( $10W@1\Omega$ ). The output impedance values refer to the loudspeaker connectors, measured directly at the cable part.

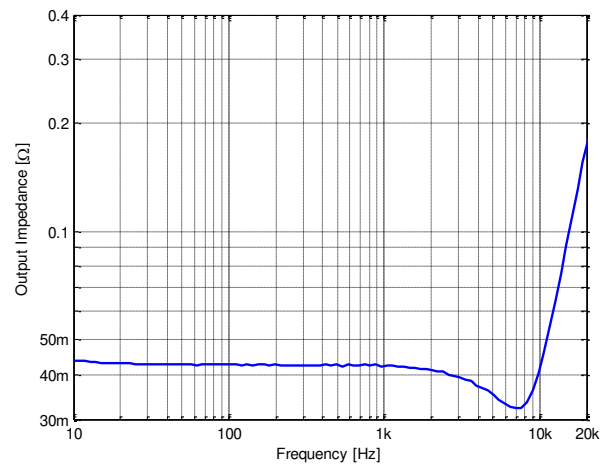

Figure 47: Output impedance magnitude[Ω]

## Capacitive loading – Single Ended Mode

With its low output impedance, the ICEpower80AM2 is designed to be unaffected by loudspeaker loading characteristics. However, care should be taken with purely capacitive loads.

Traditionally amplifiers have been tested extensively in laboratories with purely capacitive loads. This was done to test the amplifier's stability and performance but it does not relate to any normal speaker load as even electrostatic speakers do not present a purely capacitive load to the amplifier but include a resistive part as well. The maximum purely capacitive load allowed is 390nF.

## Output Impedance – BTL Mode

The output impedance is calculated from measured amplifier gain and phase, unloaded and  $1\Omega$  loaded. Output voltage is  $3.16V_{rms}@1kHz$  ( $10W@1\Omega$ ). The output impedance values refer to the loudspeaker connectors, measured directly at the cable part.

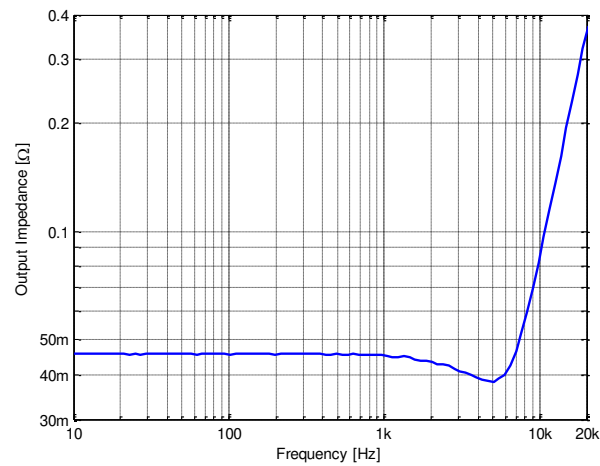

Figure 48: Output impedance magnitude[Ω]

## Capacitive loading – BTL Mode

With its low output impedance, the ICEpower80AM2 is designed to be unaffected by loudspeaker loading characteristics. However, care should be taken with purely capacitive loads.

Traditionally amplifiers have been tested extensively in laboratories with purely capacitive loads. This was done to test the amplifier's stability and performance but it does not relate to any normal speaker load as even electrostatic speakers do not present a purely capacitive load to the amplifier but include a resistive part as well. The maximum purely capacitive load allowed is 220nF.

## Connection Diagram

The connector interface of the module uses industry standard connectors selected for long term reliability.

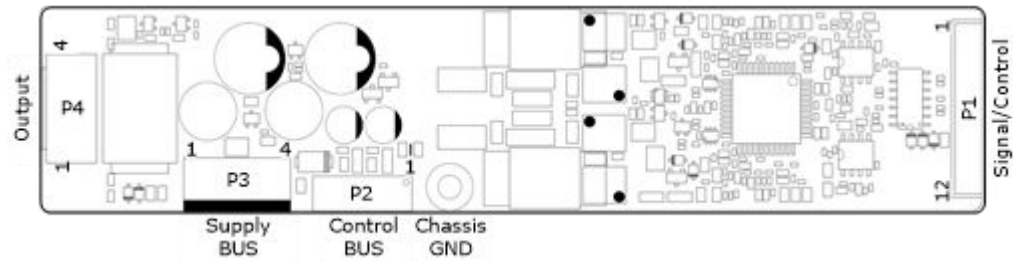

Figure 49: ICEpower80AM2 connections

## Connector Pin Description

The connections made through the Supply BUS and Control BUS are chain-connecting the number of ICEpower80AM2 amplifier modules in the system to the ICEpower400SM power supply.

### External Signal/Control Header Specification (P1)

PCB part - Manufacturer: JST ; MPN: B12B-PH			
Pin	Designation	Description	Type
1	GND A	Amplifier GND	GND
2	Vin+ ch2	Balanced input + for amplifier	Analog input
3	Vin- ch2	Balanced input - for amplifier	Analog input
4	GND A	Amplifier GND	GND
5	Vin+ ch1	Balanced input + for amplifier	Analog input
6	Vin- ch1	Balanced input - for amplifier	Analog input
7	GND A	Amplifier GND	GND
8	Disable	Active low. Amplifier enabled when pin is floating/high	Input
9	BTL_sync	Active low. Control signal for BTL synchronization	Input
10	Ch2_mon	Amplifier output monitor	Analog output
11	Ch1_mon	Amplifier output monitor	Analog output
12	GND A	Amplifier GND	GND

Table 21: External Control/Status connector specification

### Amplifier Control BUS Header Specification (P2)

PCB part - Manufacturer: Tyco ; MPN: 338068-8 (Micro-MaTch)			
Pin	Designation	Description	Type
1	CA_Vclip+	Reduce amplifier max out to protect SMPS	Analog input
2	CA_Vclip-	Reduce amplifier max out to protect SMPS	Analog input
3	GND A	Amplifier GND	GND
4	VDD	+5V amplifier supply voltage	Input
5	VSS	-5V amplifier supply voltage	Input
6	CA_Thermal	Common amplifier thermal monitor, active low (Needs external 10k $\Omega$ Pull-Up if NOT used with 400SM)	Output
7	CA_OC	Common amplifier over current monitor, active low (Needs external 10k $\Omega$ Pull-Up if NOT used with 400SM)	Output
8	CA_DC_protect	Common amplifier DC protect, active low	Output

Table 22: Amplifier Control BUS connector specifications

### Amplifier Supply BUS Header Specifications (P3)

PCB part - Manufacturer: JST ; MPN: B4P-VR			
Pin	Designation	Description	Type
1	VD	Amplifier positive supply	Input
2	GND A	Amplifier GND	GND
3	VS	Amplifier negative supply	Input
4	Vdrive	Vdrive supply voltage, +12V relative to VS	Input

Table 23: Amplifier Supply BUS connector specifications

### Amplifier Output Header Specification (P4)

PCB part - Manufacturer: JST ; MPN: B4P-VH			
Pin	Designation	Description	Type
1	Vout+ Ch1	Amplifier positive output	Output
2	Vout- Ch1	Channel 1 negative output (GND, do not ground)	Output
3	Vout- Ch2	Channel 2 negative output (GND, do not ground)	Output
4	Vout+ Ch2	Amplifier positive output	Output

Table 24: Amplifier Supply BUS connector specifications



## External Interfacing

### External Signal/Control (P1)

#### Audio Interfacing

The audio interface on the ICEpower80AM2 is designed to be very versatile and support both single ended and balanced source signals. Both + and - inputs will present the source to a load impedance of approximately 47kOhm.

#### Notice

When a single ended source signal is used, it is highly recommended to connect the ICEpower80AM2 minus input to the analog source GND in order to utilize the high common mode suppression of the amplifier and thus suppress hum and noise in a high quality multi-channel system.

The implementation of the ICEpower80AM2 audio interface is shown below in Figure 50

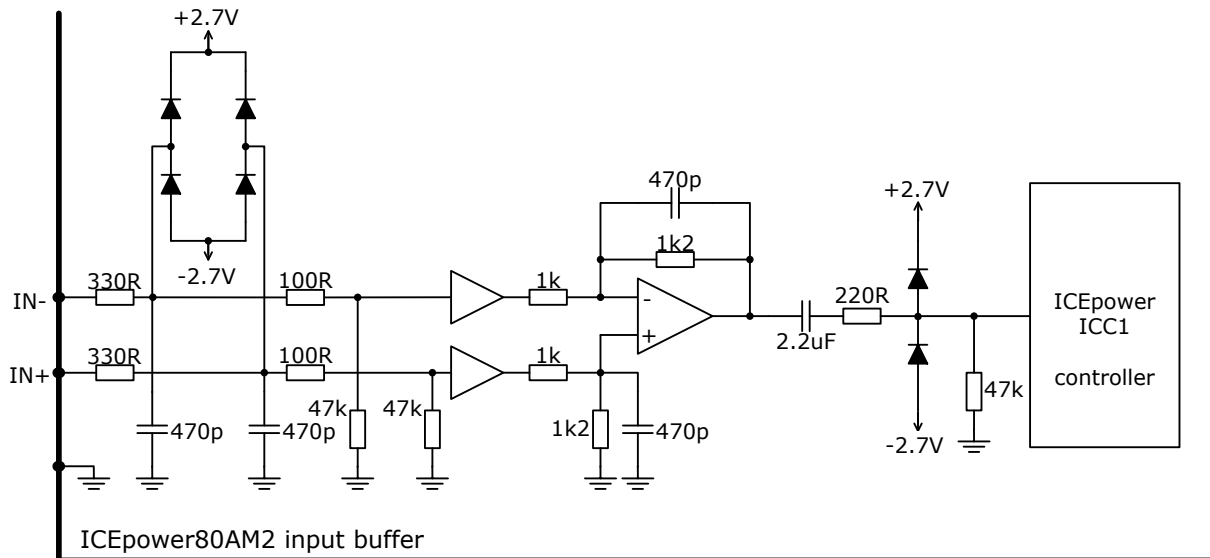

Figure 50: Audio interface of ICEpower80AM2

The input buffers are supplied by  $\pm 5V$  but will accept signals of up to  $\pm 12V$  peak without damaging the amplifier.

#### 2-channel configuration with balanced input

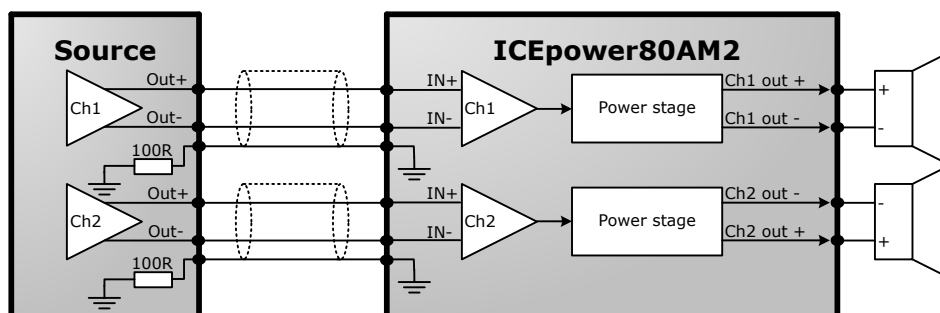

Figure 51: 2-channel configuration, balanced input

2-channel configuration with single ended input

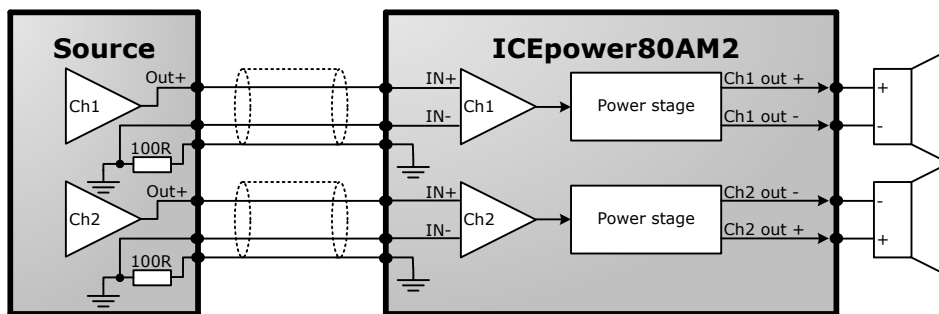

Figure 52: 2-channel configuration, single ended input

BTL configuration with balanced input

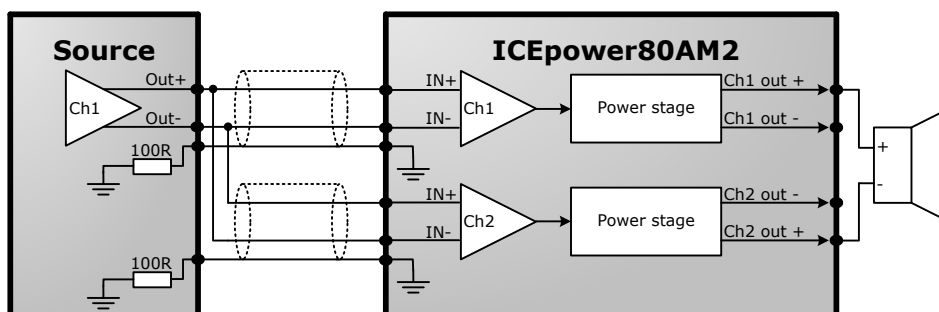

Figure 53: BTL configuration, balanced input

BTL configuration with single ended input

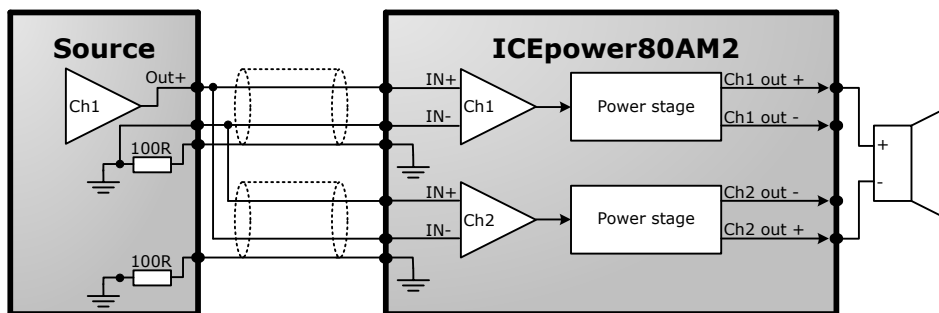

Figure 54: BTL configuration, single ended input

BTL\_sync

In 2-channel operation, leave this pin floating or high impedance.

For BTL operation connect the balanced inputs in anti-phase and pull the BTL\_sync pin to ground. Pulling the pin to ground will synchronize channel 1 and 2 for optimum audio performance.

### Monitor output

The monitor output provides a non-buffered -20dB gain signal from the output of the amplifier, when loaded with an impedance of 10kOhm. If the monitor signal is wanted, ensure that a buffer is used to drive the next circuits in the signal chain to avoid other kind of loading of the monitor output.

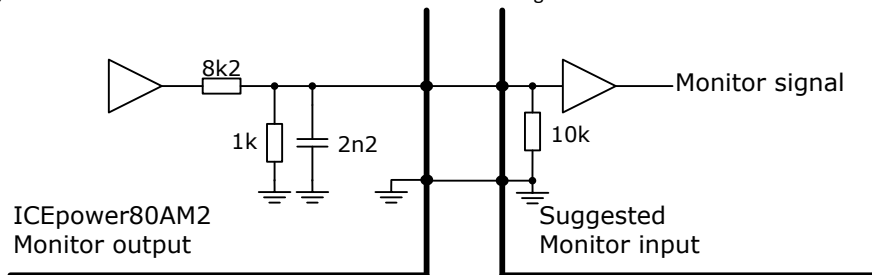

Figure 55: Monitor output and suggested monitor receiver

### Disable

The disable pin is used to control the switching of the amplifier. When pulled to ground, the switching of the power stage will stop, and the power consumption of the module is greatly reduced. The disable pin must be pulled low during the power on/off cycle of the ICEmatch system, as this may prevent damage to the module when used in open/no load condition. Also, this will lower amplifier on/off “plop”.

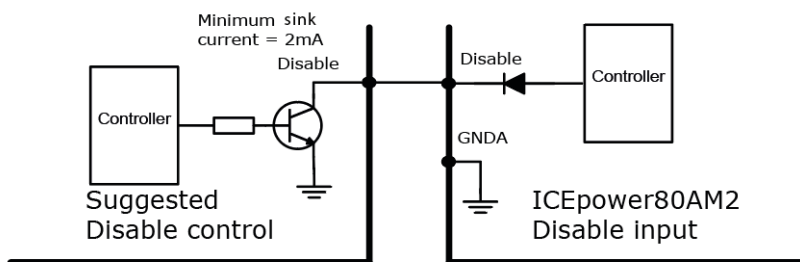

Figure 56: Suggested Disable implementation

### Amplifier Output (P4)

#### Single ended configuration

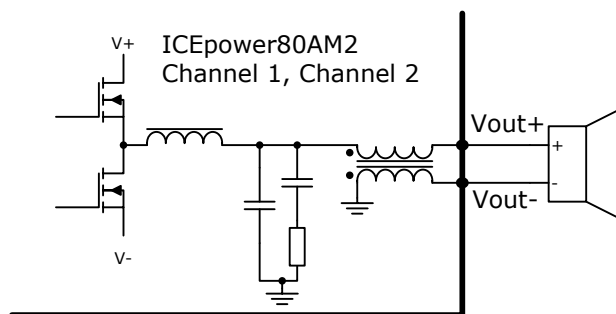

Figure 57: Single ended output topology

## BTL Configuration

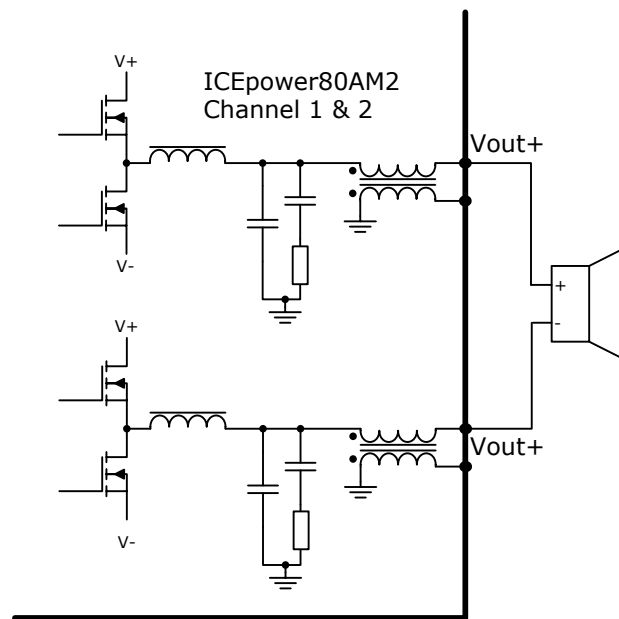

Figure 58: BTL configuration

Notice that for BTL operation, the load is connected between the hot pins of the two single ended channels. The polarity of the load must be in accordance with the polarity of the signal input connections to obtain proper absolute phase at the output. See Figure 53 or Figure 54.

## Protection Features

### Thermal protection

The two half bridge amplifiers on the ICEpower80AM2 module are each protected by a thermal sensor. When one or both of these sensors are triggered the amplifier module will shut down to protect itself. The thermal trigger points are approximately 105 degree C on the power MOSFETs.

When the thermal limit is exceeded the module will shut down and go into soft start cycle and thus when cooled below the trigger temperature startup again and be fully operational.

In the event of a thermal protection the CA\_Thermal pin is pulled low which can be observed at the ICEpower400SM P4 connector. See Table 10. The pin is pulled up with a 10kΩ resistor to 5V VDD on the 400SM.

### Amplifier Output Current Limiter

The amplifier output is current limited to about 20A peak. This is done to protect the power stage against overload during a short circuit event on the output of the amplifier.

In the event of an over current situation, the module will communicate the protection event by pulling the CA\_OC pin low. This can be observed at the ICEpower400SM P4 connector. See Table 10. The pin is pulled up with a 10kΩ resistor to 5V VDD on the 400SM.

If the module is not used in conjunction with the 400SM an external 10kΩ pull-up can be used.

### Output Filter (Zobel) and HF Output Protection

The amplifier has full audio bandwidth, but to protect the Zobel RC network, the amplifier will not allow full scale signals on the output at frequencies above 15 kHz for a longer period of time. Please see the graph below. If this is tested under laboratory conditions, the module will shut down to protect against overheating of the Zobel resistors. When playing music signals this protection will not intervene due to the power distribution of music signals.

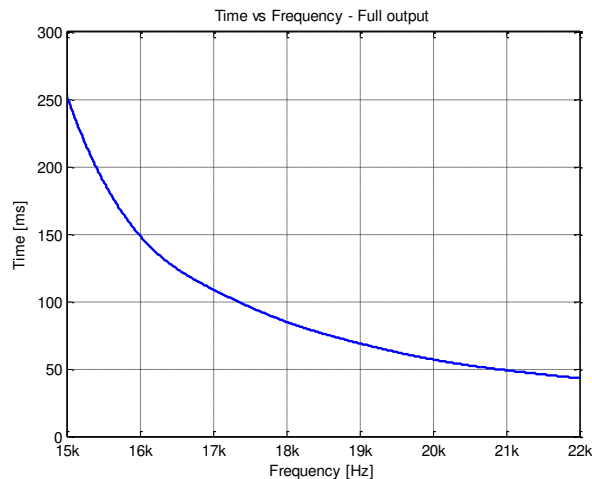

### DC Detector

Defects in the amplifier are rarely seen to generate DC on the output. However, a DC detection circuit is included on both channels to detect this failure type. If DC is detected on the amplifier output the ICEpower400SM power supply is immediately switched off to protect the loudspeaker. The power supply will automatically try to restart after a short period of time and if the DC error still exists it will immediately switch off again.

## Physical Dimensions

Note the location of pin 1 of all connectors. All dimensions are in mm.

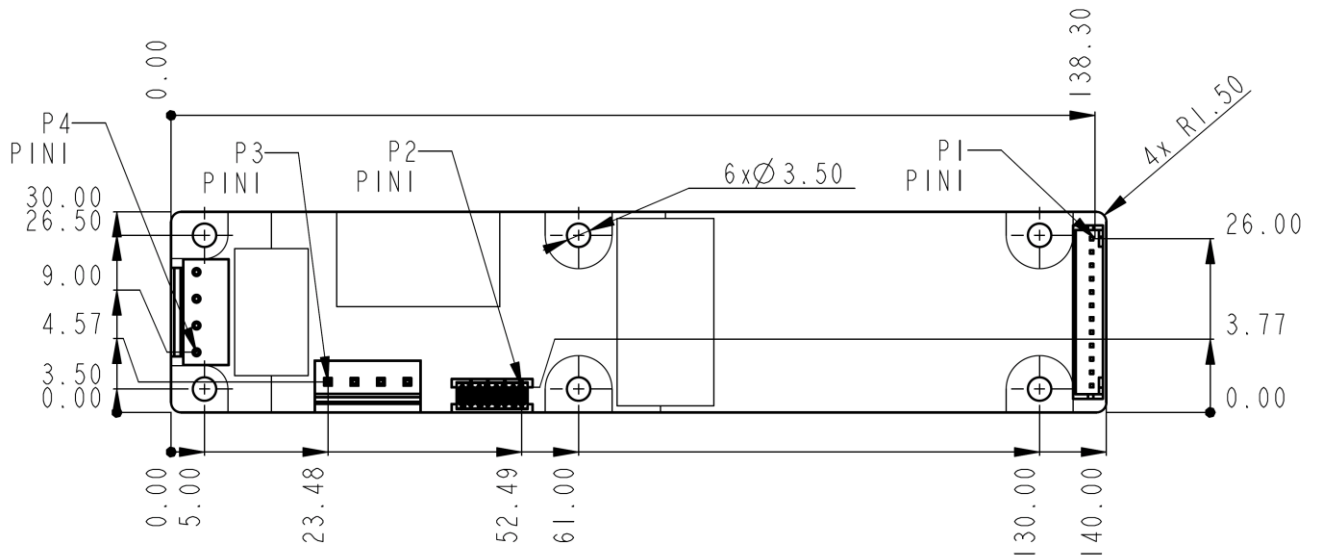

Figure 59: ICEpower80AM2 board mechanical outline. Physical dimensions in mm.

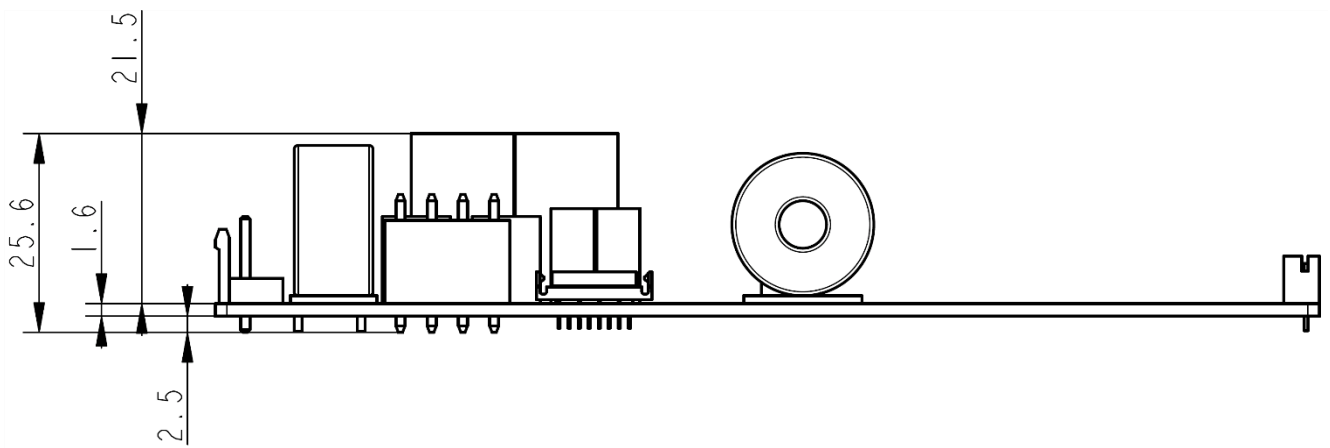

Figure 60: Side view of the ICEpower80AM2 board. Physical dimensions in mm.

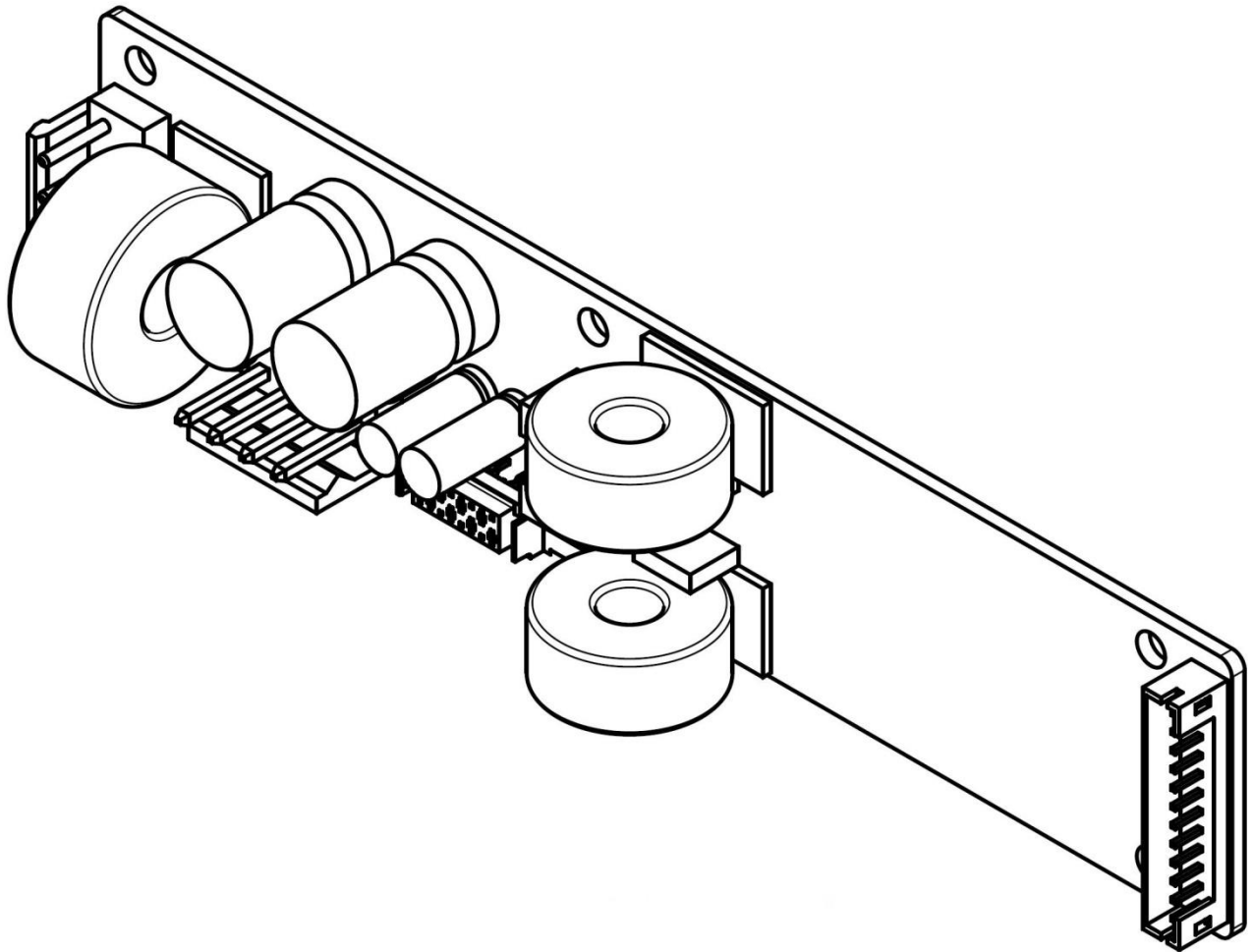

Figure 61: 3D-view of the ICEpower80AM2 board.

## System Design

When designing a system proper attention has to be paid to thermal properties for best possible power handling, cable routing for best possible electromagnetic compatibility and mechanical mounting for reliability and ease of manufacturing.

### Thermal Design

The ICEpower80AM2 module is designed for music reproduction, which means that the output signal of the amplifier will never be a continuous sinusoidal wave during typical usage. Research has shown that the RMS power level of any full bandwidth music signal does not normally exceed 1/8<sup>th</sup> of the rated power when the music signal is not clipped. Consequently the amplifier and cooling surfaces are designed for large short-term power handling and lower continuous power handling.

The module is capable of approximately 2 x 20W RMS at 25 degrees ambient temperature. This is true for both sine wave loading and pink noise and this level exceeds 1/8<sup>th</sup> of the nominal power capability by a factor of 2.

There is no heat-sink on the ICEpower80AM2 module, since the power losses are very low compared to an equivalent Class A/B amplifier. The idle consumption of the ICEpower80AM2 module is low and the power loss will not increase significantly during music reproduction due to the high efficiency characteristics of the ICEpower Class D technology.

Mounting a module in a confined space with inadequate air flow properties will rise the module temperature and thus limit the maximum power level achievable. The devices with the highest temperature will be power MOS FETs, transformers and coils mounted on both the power supply and the amplifiers.

Mounting the ICEpower400SM together with eight ICEpower80AM2 in a 1U 19" rack cabinet will require attention to air flow within the cabinet as well as the materials used. It is recommended to have either adequate airflow through ventilation holes in both top and bottom plates of the cabinet or to implement a temperature controlled fan. If the cabinet is mounted in a rack system the fan solution is preferred as natural convection can be obstructed by other rack cabinets.

Important Note! Always ensure sufficient clearance for live parts and adequate ventilation.

### Recommended module placement and wiring within a 19" rack cabinet

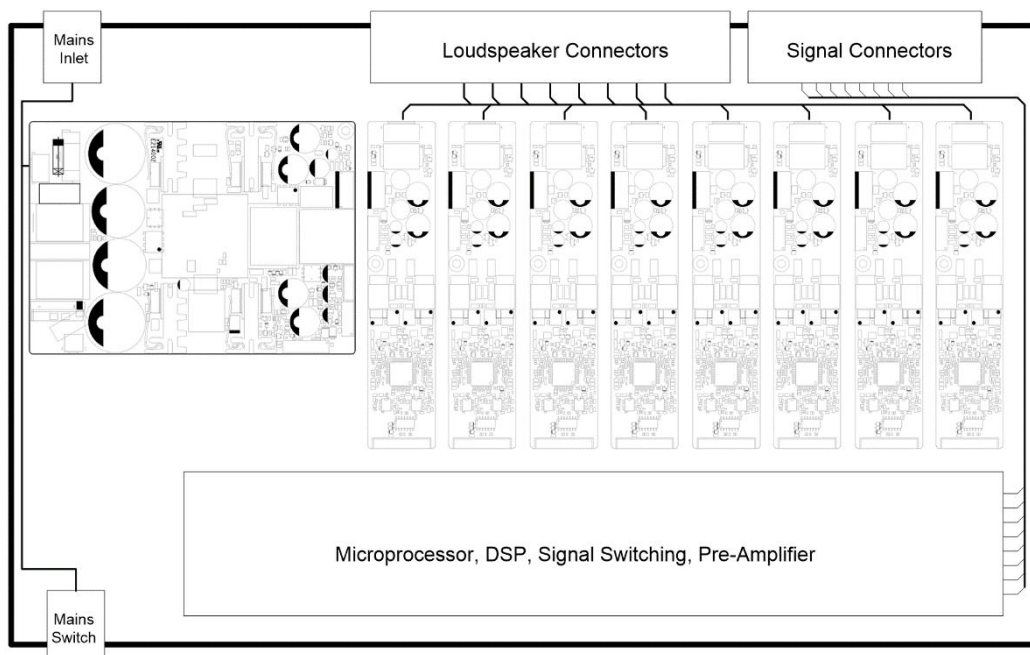

Figure 62: Suggested module mounting in a 19" rack cabinet





## EMC Design

As the system contains a power supply and amplifiers using switching technology proper EMC design considerations has to be taken into account. Also the Pre-amplifier may include a DSP and/or microcontroller circuits. Thus, it may prove necessary to include EMC filters on all inputs and outputs entering the metal cabinet.

It is important to note that these EMC filters must be mounted very close the connectors in the cabinet walls and they must have good electrical connection to the cabinet (chassis).

Note: The minus output of the ICEpower80AM2 amplifier must not be directly connected to chassis as this will leave the on board EMC common mode coil useless and create distortion of the audio signal.

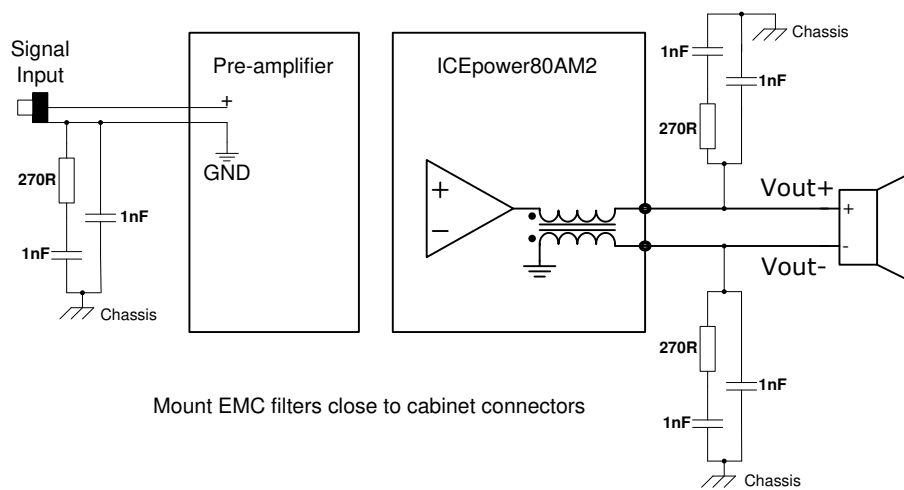

Figure 63: Suggested EMC filters

## Typical Timing Specifications

Unless otherwise specified,  $T_a=25^{\circ}\text{C}$  and  $V_{\text{mains}} = 230\text{V AC}$

Symbol	Parameter	Conditions	Min	Typ	Max	Unit
$t_{\text{mains.standby}}$	Time from mains voltage to standby voltage OK	$V_{\text{mains}} = 85 - 264\text{Vac}$		2		s
$t_{\text{mains.}\pm 12\text{V}}$	Time from mains voltage to $\pm 12\text{V OK}$	3-5V connected to 5V_Stb $V_{\text{mains}} = 85 - 264\text{Vac}$		2.3		s
$t_{\text{on.Green\_LED}}$	Time from 3-5V to Green_LED output	4.7k between Green_LED to GND		<0.5		ms
$t_{\text{on.}\pm 12\text{V}}$	Time from 3-5V to $\pm 12\text{V OK}$			250		ms
$t_{\text{off.Green\_LED}}$	Time from 3-5V low to Green_LED output	4.7k between Green_LED to GND		90		ms
$t_{\text{off.standby}}$	Time from 3-5V low to standby converter in standby mode			180		ms
$t_{\text{signal.Green\_LED}}$	Time from signal sense input to Green_LED	Signal_sense+ = 100Hz, 10mV <sub>rms</sub> Signal_sense- = GND		600		ms
$t_{\text{Green\_LED.on}}$	Time from Green_LED to on mode (high load of standby converter)			12		ms
$t_{\text{Green\_LED.}\pm 12\text{V}}$	Time from Green_LED to on mode			250		Ms
$t_{\text{signal.standby}}$	Hold time from no signal to standby mode	Signal_sense+ = 100Hz, 100mV <sub>rms</sub> , 10 seconds Signal_sense- = GND		>700		s
$t_{\text{Green\_LED.standby}}$	Time from Green_LED off to standby mode (low load off standby converter)	4.7k between Green_LED to GND		40		ms
$t_{\text{reset}}$	Time to reset signal sense circuit	12V trigger and 3-5V trigger both pulled high		100		ms
$t_{\text{Audio\_Out}}$	Time from Mains to Audio Out	3-5V_Trigger enabled, Amplifier Enabled		2.5		s
$t_{\text{Audio\_Enable}}$	Time from Amplifier Enable to Audio Out	400SM already running		120		ms
$t_{\text{Audio\_Disable}}$	Time from Amplifier Disable to Amplifier Output Disabled	400SM already running		4		ms
$t_{\text{Signal\_On}}$	Time from Signal Sense Input to Audio Out	Signal_sense+ = 100Hz, 10mV <sub>rms</sub> Signal_sense- = GND		1		s

## Environmental Specifications

Parameter	Conditions	Min	Typ	Max	Units
Ambient temperature, operating	Natural convection cooling	0		50	°C
Ambient temperature, storage		0		70	°C
Relative humidity	Non-condensing			85	%
Altitude, operating				2000	m

Table 25. Environment specification

## Safety Standards

The ICEmatch modules are safety pre-approved to ease the design-in procedure. The modules comply with the following standards:

Europe: IEC 60065 7th ed. + AM1 + AM2  
 IEC 60065 8th ed.  
 EN 60065:2002 + A1:2006 + A11:2008 + A2:2010 + A12:2011  
 EN 60065:2014  
 EN 62368-1:2014 2<sup>nd</sup> ed.  
 IEC 62368-1:2014 2<sup>nd</sup> ed.

US: UL 60065, 7th Edition, 2013-07-24  
 UL 62368-1 2ND Ed  
 CAN/CSA-C22.2 No. 60065-03, 1st Edition + A1:2006 + A2:2012  
 CAN/CSA-C22.2 NO. 62368-1 2nd Ed

Safety Class: Class 2

## Touch Current

Touch Current is measured according to IEC 60999 with the following result.

Point of Measurement	Measurement Result	Specified Limit, IEC60065
U1	202mVpeak	35Vpeak
U2	158mVpeak	350mVpeak

## Disturbances on the Mains

The signal on the mains connection is often very noisy and large surge voltages are present. The ICEpower400SM is equipped with mains filtering to suppress surges and noise.

The ICEpower400SM is able to withstand surge transients (lightning) up to 6kV common mode.

## EMC

When mounted in a cabinet with the proposed EMI precautions as shown the ICEmatch solution fulfill the following requirements with good margin.

- EN 55013:2001 + Amendment A1:2003 + Amendment A2:2006
- EN 55020:2007
- EN 61000-3-2:2006
- EN 61000-3-3:2008
- Code of Federal Regulations (CFR) 47 Part 15, Subpart B (Class B digital device)
- CISPR 13:2006 (edition 5.0)
- CISPR 20:2006 (edition 6.0)
- IEC 61000-3-2:2009 (edition 3.2)
- IEC 61000-3-3:2008 (edition 2.0)
- EN 55032: Note 1

Note1: Depends on cable routing on the mains/amplifier outputs and load characteristics. Connecting safety ground to the mains side/ Additional filtering may be needed.

## Electrostatic Discharge

Type	Test Level	Environment
Internal Contact, small signal connectors	5kV	Production, handling, service
External Contact, loudspeaker and mains	8kV	End User

## Environmental and Reliability Tests

ICEpower has conducted the following environmental and reliability tests.

Conducted Test	Sub-test	Performance Verification
Lifetime Test		Continuous monitoring
Storage tests	Damp heat	After test
	Damp heat with condensation	After test
	Dry heat	After test
	Low temperature	After test
	Rapid change of temperature	After test
Functional tests	Damp heat	Continuous monitoring
	Dry heat	Continuous monitoring
	Low temperature	Continuous monitoring
Accelerated thermal stress test		No thermal stress factors

## Mechanical Tests

The ICEpower400SM and the ICEpower80AM2 have passed the following mechanical tests to ensure high reliability. Resonance search carried out during sinusoidal vibration test.

Test	Acceleration	Amount	Performance Verification
Random vibration	2.1g <sub>RMS</sub> <sup>1)</sup>	3x20min + 3x10min + 3x10min	After test
Bump	10g/16ms, 2-4 Hz	1000 bumps in each of 6 directions <sup>2)</sup>	After test
Shock	70g/12ms	3 shocks in each of 6 directions <sup>2)</sup>	After test
Sinusoidal vibrations	2.5mm, 5-10Hz 1g, 10-100Hz	2 hours in each of 3 directions <sup>2)</sup>	Continuous monitoring
Random vibrations	0.01g, 10-20Hz 0.7g <sub>RMS</sub> -3dB/oct, 20-150Hz	2 hours in each of 3 directions <sup>2)</sup>	Continuous monitoring

Table 26: Mechanical tests.

<sup>1)</sup> See Table 27: Random Profile for details

<sup>2)</sup> 6 directions: (up, down, left, right forward and backward). 3 directions: (up and down, left and right, forward and backward)

Random Profile (~2.1g RMS)		
Frequency [Hz]	Acceleration [(gn) <sup>2</sup> /Hz]	Slope [dB/Oct]
5	0.0005	9
37	0.2	
40	0.2	-14
137	0.00055	
275	0.00055	

Table 27: Random Profile

## ESD Warning

ICEpower products are manufactured according to the following ESD precautions:

- IEC 61340-5-1: Protection of electronic devices from electrostatic phenomena. General Requirements.
- IEC 61340-5-2: Protection of electronic devices from electrostatic phenomena. User Guide.
- ANSI/ESD-S20.20-1999: Protection of Electrical and Electronic Parts, Assemblies and Equipment.

Further handling of the products should comply with the same standards.

The general warranty policy of ICEpower a/s does not cover ESD damaged products due to improper handling.

## Packaging and Storing

### Dimensions and weight ICEpower400SM

Package	Quantity	Dimensions (w x d x h)	Gross Weight
Carton	15	390 x 290 x 195mm	8.8Kg
Pallet	240	800 x 1200 x 1172	224Kg

ESD safe cardboard is used for wrapping.

### Dimensions and weight ICEpower80AM2

Package	Quantity	Dimensions (w x d x h)	Gross Weight
Carton	56	390 x 290 x 195mm	5.1Kg
Pallet	448	800 x 1200 x 1172	372Kg

ESD safe cardboard is used for wrapping.

### ICEmatch Order Codes

Order Codes	Description	Part Number
ICEpower400SM	ICEpower 400W ICEmatch Supply	8005542
ICEpower80AM2	ICEpower 2 x 80W ICEmatch Amplifier	8007610

## Stacking

Pallets may not be stacked on top of each other.

## Contact

For additional information about the ICEpower® technology from ICEpower a/s, visit our web site or contact us.

ICEpower a/s  
Vandtårnsvej 62A. 3rd floor B  
DK-2860 Søborg  
Denmark

[www.icepower.dk](http://www.icepower.dk)  
[info@icepower.dk](mailto:info@icepower.dk)

## Legal Notes

ICEpower a/s believes that the information in this datasheet is accurate and reliable. However it is provided "as is" without any warranties of any kind. ICEpower a/s and its suppliers, to the fullest extent permitted by law, disclaim all warranties, including the warranty of merchantability, warranty of non-infringement of third-party rights, and the warranty of fitness for a particular purpose. ICEpower a/s and its suppliers make no warranties about the accuracy, reliability, completeness, or timeliness of the material, services, software, text, graphics and links. In no event will ICEpower a/s be liable to any party for any damages whether direct, indirect, special, consequential or other for any use or inability to use of this datasheet, including, without limitation, any damages for lost profits, business interruption, loss of programs or other data on your information handling system or otherwise, even if we are expressly advised of the possibility of such damages.

Information in this datasheet may contain technical inaccuracies or typographical errors. The information in the datasheet may be changed at any time without prior notice or obligation.

ICEpower® is a trademark of ICEpower a/s.

ICEpower a/s products are not authorized for use as critical components in life support devices or life support systems without the express written approval of the president and general counsel of ICEpower a/s. As used herein:

- Life support devices or systems are devices or systems which, (a) are intended for surgical implant into the body, or (b) support or sustain life, and whose failure to perform when properly used in accordance with instructions for use provided in the labelling, can be reasonably expected to result in a significant injury to the user.
- A critical component is any component of a life support device or system whose failure to perform can be reasonably expected to cause the failure of the life support device or system, or to affect its safety or effectiveness.

ICEpower a/s ©2018