

# Hitmaker

## MT Bookshelf Speaker Kit

The Hitmakers are designed as a straightforward DIY speaker that any home recording studio owner can assemble and expect great results. The Hitmakers have just enough resolution and detail for critical listening without becoming fatiguing. Imaging is precise for such a small speaker and the soundstage allows for natural placement of sounds. In addition, the bass extension is deeper than what you get from most nearfield monitors, which might come in handy for some musicians and producers.

The drivers for the Hitmaker were chosen due to their low distortion and accurate response. The Dayton Audio DA175-8 7" aluminum cone woofer handles the lower octaves, delivering surprising bass response with incredible accuracy. For the top few octaves this kit uses the Peerless by Tymphany BC25TG15-04 1" silk dome tweeter, which is both accurate and detailed without being harsh.

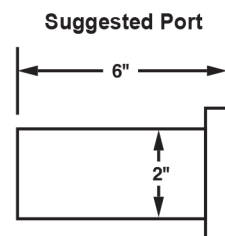
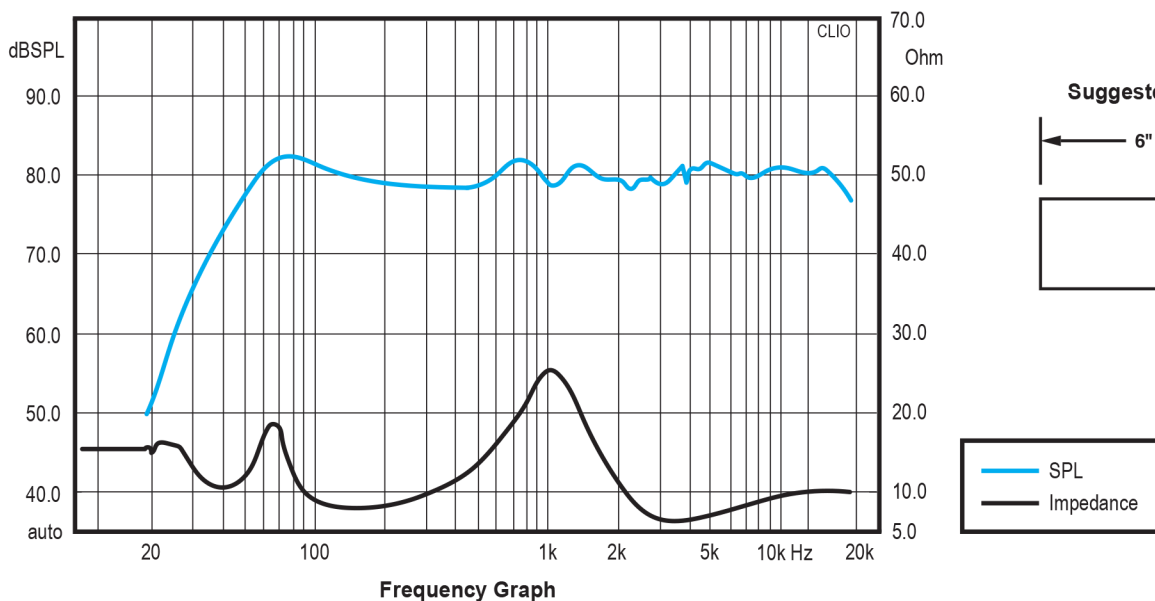

**Specifications:** • Impedance: 8 ohms • Frequency response: 45 - 20,000 Hz • SPL: 82 dB 1W/1m • Power Handling: 70 watts RMS/140 watts max.

**Crossover Diagram**

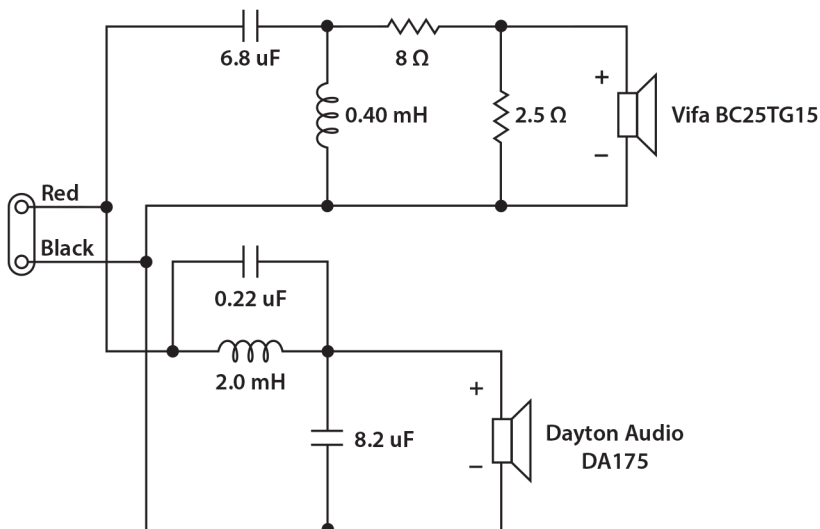

**Cabinet Dimensions**

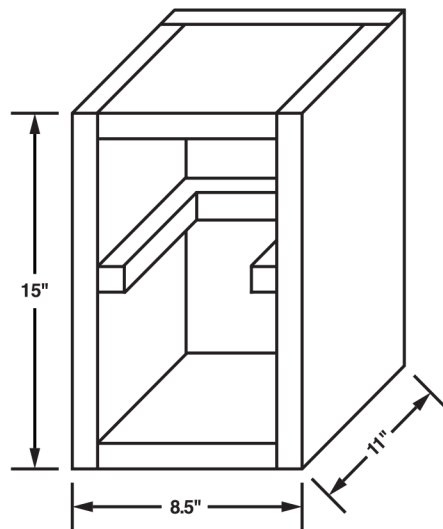

The crossovers included with this kit were optimized for the above driver/cabinet combination. A diagram of the optimal cabinet has been provided as a guideline. Varying greatly from the optimal cabinet volume may result in changes to the frequency response and less than desired performance.

## Parts Inventory

Before beginning the assembly process, please read this manual in its entirety and confirm that you have all necessary components listed below. If anything appears to be missing, please contact your place of purchase immediately. **Note:** Screws, binding posts, and speaker wire are not included.

Qty	Part #	Description
1	027-424	Dayton Audio DMPC-6.8 6.8uF 250V Polypropylene Capacitor
1	027-402	Dayton Audio DMPC-0.22 0.22uF 250V Polypropylene Capacitor
1	027-426	Dayton Audio DMPC-8.2 8.2uF 250V Polypropylene Capacitor
1	255-224	Jantzen Audio 0.40mH 18 AWG Air Core Inductor Crossover Coil
1	255-266	Jantzen Audio 2.0mH 18 AWG Air Core Inductor Crossover Coil

Qty	Part #	Description
1	004-8	Dayton Audio DNR-8.0 8 Ohm 10W Precision Audio Grade Resistor
1	004-2.4	Dayton Audio DNR-2.4 2.4 Ohm 10W Precision Audio Grade Resistor
1	264-1040	Peerless by Tymphany BC25TG15-04 1" Silk Dome Tweeter
1	295-335	Dayton Audio DA175-8 7" Aluminum Cone Woofer
1	260-387	Speaker Cabinet Port Tube 2" ID Adjustable
1	260-520	Sonic Barrier 1/2" Acoustic Foam w/PSA 18" x 24"

## Troubleshooting

The following troubleshooting guide is based on the assumption that an adequate well constructed cabinet is being utilized. In most cases the cause of a problem will be traced back to the improper wiring of the crossover and not a faulty driver. Common mistakes: using the wrong harness, improper polarity, bad or loose connections.

**Problem:** No output from speaker system.

**Cause:** Bad connection.

**Solution:** Check connections from the stereo to the input of the speaker system. If OK, check the connection from the binding post to tweeter and woofer input terminals. If this is OK, Test speaker on another system. If sound comes out check initial stereo settings and connections (speakers on/off). If there is no sound at all, please contact your place of purchase immediately.

**Problem:** No output from woofer in individual speaker.

**Cause:** Bad connection or defective woofer.

**Solution:** Check connections from crossover board to woofer. If this is OK, directly test the woofer by hooking it up to stereo system at low volume setting. If sound comes out of the woofer, then go back and check connections. If there is no sound at all, then woofer is likely defective. Please contact your place of purchase immediately.

**Problem:** No output from tweeter in individual speaker.

**Cause:** Bad connection or defective tweeter.

**Solution:** Check connections from crossover board to tweeter. If OK, it is possible to carefully test the tweeter by directly connecting it to your stereo. Test at a very low volume for a brief period of time, at the level of a loud whisper. If there is high-frequency sound, then go back and check connections. If no sound at all, then tweeter is likely defective. Please contact your place of purchase immediately.

**Problem:** There is sound from the speaker, but it is very quiet and seems to be mostly treble or midrange.

**Cause:** Woofer and tweeter are wired backwards.

**Solution:** Immediately cease testing to prevent damage to the tweeter. Check connections from crossover board to woofer and tweeter, making sure the high pass filter denoted with a "T" on the output terminal is connected to the tweeter and the low pass filter denoted as "W" is connected to the woofer.

**Problem:** Intermittent output of entire speaker, woofer, or tweeter.

**Cause:** Bad connection in wires or crossover board.

**Solution:** If entire speaker is intermittent, then check connections between the input terminals and the crossover board. If just woofer or tweeter is intermittent, check the wires going to the drivers. If these are OK, check the connections of the components within the appropriate section of the crossover.

**Problem:** In stereo, speakers lack bass or image is unfocused.

**Cause:** Speakers are out of phase.

**Solution:** Check connections from amplifier to the speakers. Make sure polarity is the same on both speakers. If correct, check the polarity of connections going from binding posts to input on crossovers. If this does not correct the problem, check polarity throughout the rest of the system, looking for one driver that is wired incorrectly.

**Problem:** One speaker appears louder than the other.

**Cause:** Amplifier settings, environmental factors, psychoacoustics, poor connection in crossover.

**Solution:** Check your amplifier to ensure that the balance is set even. Next, check that one speaker isn't closer to a wall, window, couch, or other acoustically important object. This may affect perceived loudness due to the addition or reduction of extra sound reflections. If this is the case, physically switch the left and right speakers, and re-observe. If the same location still sounds quieter, then it is the environment. If the quiet speaker moves, then you may have a problem within the speaker. Often, if you think one speaker is louder than the other, it will appear so. Have someone help you do a blind test or take a break and allow time for your brain to relax. The next day, if one still seems louder, investigate all connections within the crossover.

**Problem:** Speakers play well, but amplifier shuts down.

**Cause:** Amplifier does not have enough power or cannot handle speaker impedance.

**Solution:** If using 4 ohm speakers, check receiver/amplifier manual to see if it can handle 4 ohm speakers or if it has a low impedance setting. If not, upgrade your amplifier. If the receiver/amplifier can safely handle the speaker load, then it may simply not have enough power.