

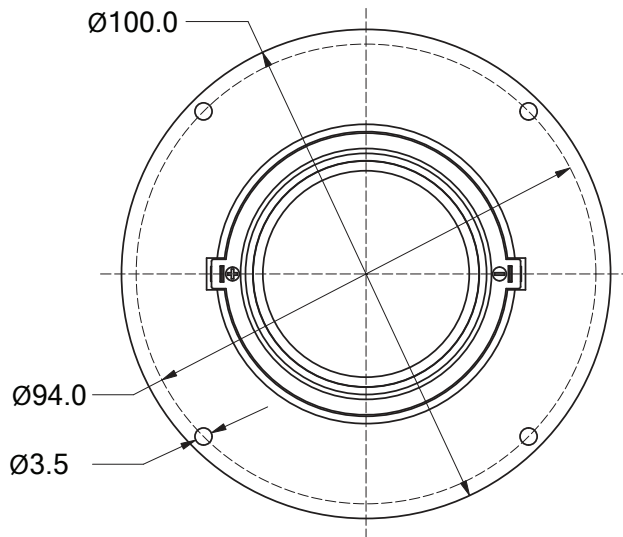

A25-2T REPLACEMENT 2" TWEETER FOR DYNACO A25 6 OHM

MECHANICAL DRAWING

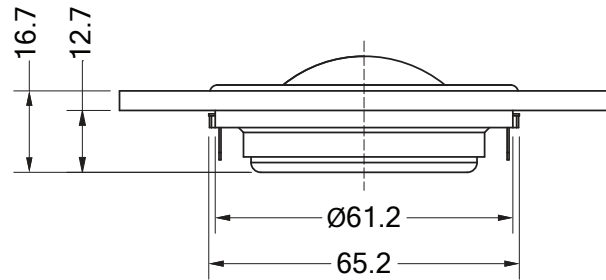

FEATURES

- Meticulously crafted replacement tweeter for the Dynaco A25
- Identical dome material with an updated motor for improved transient response and accurate music reproduction
- Fully compatible with the original Dynaco crossover network
- Dimensionally accurate design requires minimal modification for installation
- Ferrofluid cooled voice coil keeps power compression to a minimum even at high output
- Great replacement speaker

IMPEDANCE/PHASE

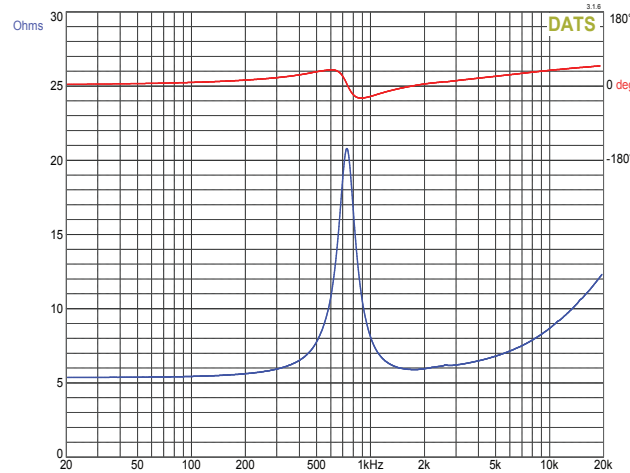

PARAMETERS

Impedance	6 ohms
Re	5.4 ohms
Le	0.08 mH@10k
Fs	730 Hz
Qms	-
Qes	-
Qts	-
Mms	-
Cms	-
Sd	-
Vd	-
BL	-
Vas	-
Xmax	-
VC Diameter	39 mm
SPL	87 dB @ 2.83V/1m
RMS Power Handling (AES 426B)	30 watts
Usable Frequency Range (Hz)	1,500 - 16,000 Hz

FREQUENCY RESPONSE

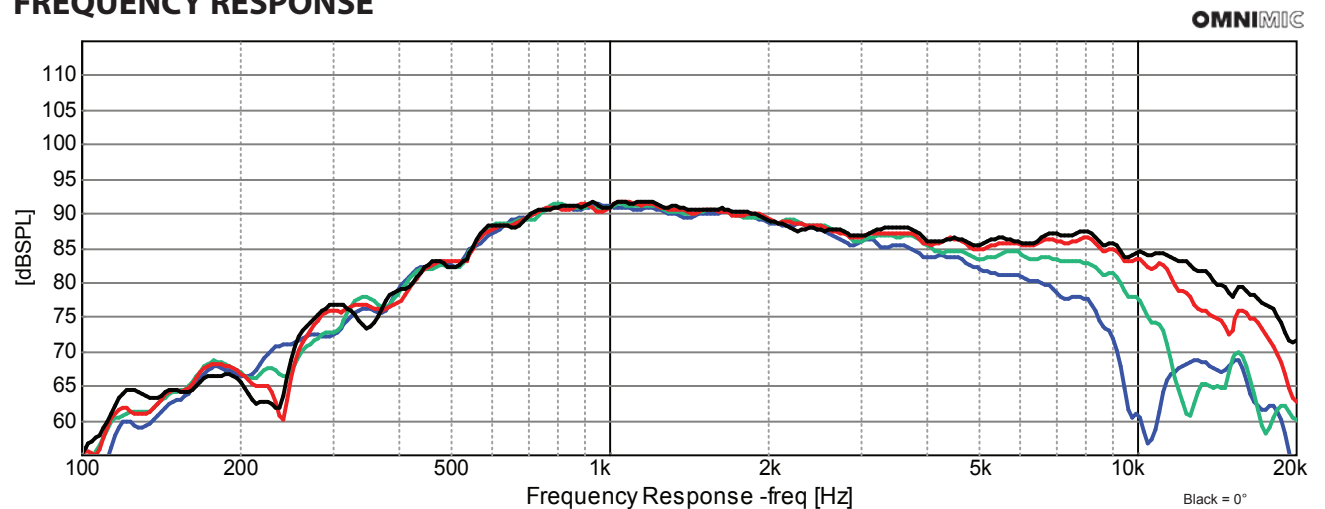

Note: 1/24th octave smoothing - nearfield response included in graph below 450 Hz.

Black = 0°
Red = 15°
Green = 30°
Blue = 45°