

Model No.: DX25TG59-04
 Product Line: Tymphany

Rev: 1
 Last Update: 2017-03-03 09:00:02

Product Description

This DX family tweeter features a 4 ohm 25 mm ferrofluid-cooled voice coil, a damped silk diaphragm with large surround roll to produce a low resonant frequency, and a ferrite magnet motor which adds heat sinking for power handling capacity. The faceplate features recessed mounting holes to minimize reflections.



Mechanical Drawing

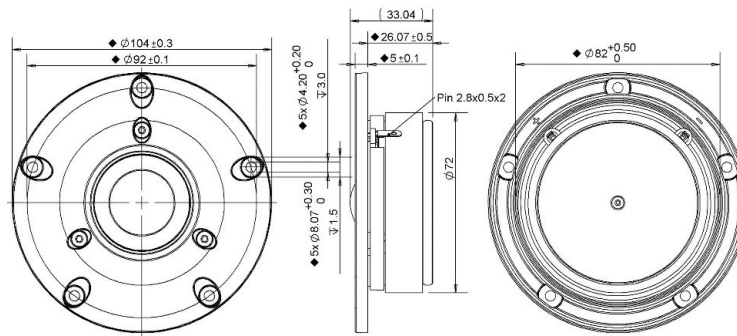

Specifications

DC Resistance	Revc	Ohms	2.93	5.0%	Energy Bandwidth Product	EBP	(1/Qes)*fs	
Minimum Impedance	Zmin	Ohms	3.78	7.5%	Moving Mass	Mms	g	0.4
Voice Coil Inductance	Le	mH	0.02		Suspension Compliance	Cms	um/N	170.2
Resonant Frequency	Fs	Hz	640.02	15%	Effective Cone diameter	D	cm	3.23
Mechanical Q Factor	Qms		2.46		Effective Piston Area	Sd	cm ²	8.2
Electrical Q Factor	Qes	0.74			Effective Volume	Vas	L	0.02
Total Q Factor	Qts	0.57			Motor Force Factor	BL	Tm	2.41
Ratio Fs/Qts	F	Fs/Qts	1128.79		Motor Efficiency Factor	β	(T*M ²)/Ohms	2
Half Space Sensitivity @2.83V	db@2.83V/1M	dB	93.02	+/- 1.0db	Voice coil former Material	VCfm		ASV
Half Space Sensitivity @1W/1M	db@1W/1M	dB	89.8	+/- 1.0db	Voice coil inner diameter	VCd	mm	25.76
Gap Height	Gh	mm	2		Rated Noise Power	P	W	100
Maximum Linear Excursion	Xmax	mm	0.1		Test Spectrum Bandwidth		2.5KHz-20KHz	
Ferrofluid Type	FF		APGS11N		Driver Size	Inch	25 mm	
Driver Mass	Kg	0.5						

Frequency and Impedance Response

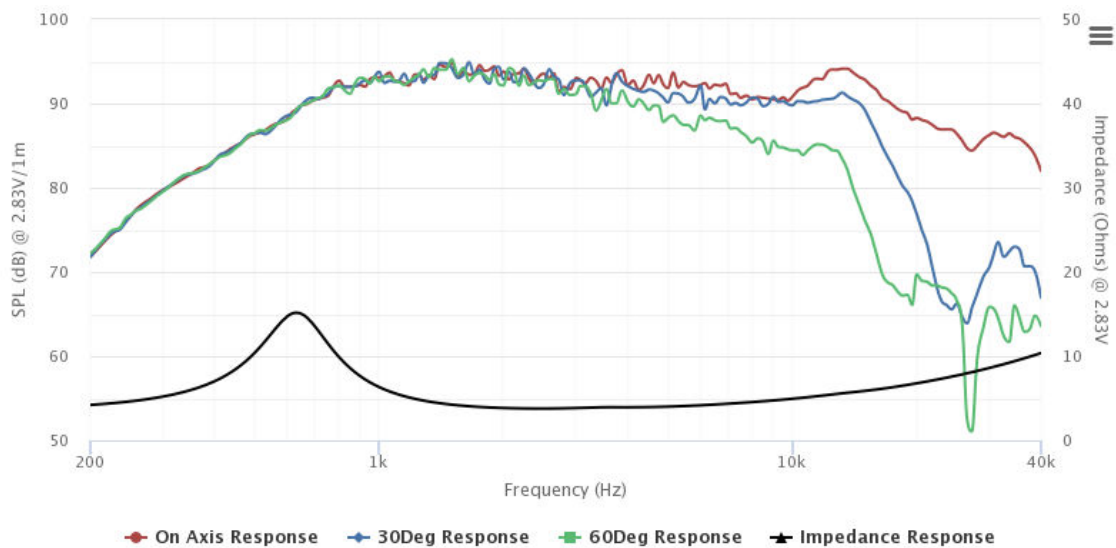

Highcharts.com