

Model No.: DX20BF00-04
 Product Line: Tymphany

Rev: 1
 Last Update: 2017-04-25 21:32:09

Product Description

This DX family tweeter features a 19mm 4 ohm voice coil, a damped silk diaphragm with large surround roll to produce a low resonant frequency, and a ferrite magnet motor which adds heat sinking for power handling capacity. The faceplate features recessed mounting holes to minimize reflections.



Mechanical Drawing

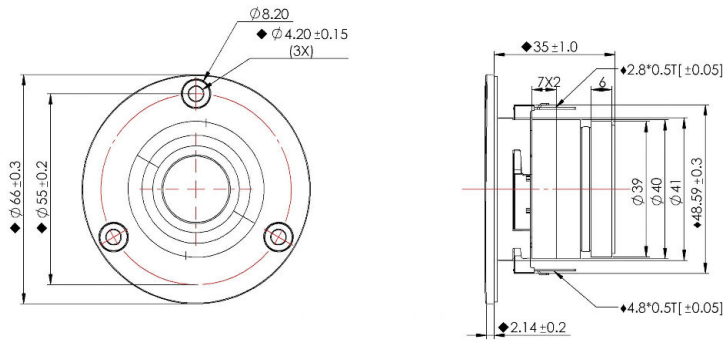

Specifications

DC Resistance	Revc	Ohms	2.81	5.0%	Energy Bandwidth Product	EBP	(1/Qes)*fs	
Minimum Impedance	Zmin	Ohms	3.83	7.5%	Moving Mass	Mms	g	0.2
Voice Coil Inductance	Le	mH	0.01		Suspension Compliance	Cms	um/N	184.5
Resonant Frequency	Fs	Hz	822.14	15%	Effective Cone diameter	D	cm	2.5
Mechanical Q Factor	Qms		2.24		Effective Piston Area	Sd	cm ²	4.9
Electrical Q Factor	Qes	2.93			Effective Volume	Vas	L	0
Total Q Factor	Qts		1.27		Motor Force Factor	BL	Tm	1
Ratio Fs/Qts	F	Fs/Qts	647.35		Motor Efficiency Factor	β	(T*M ²)/Ohms	0.4
Half Space Sensitivity @2.83V	db@2.83V/1M	dB	90.14	+/- 1.0db	Voice coil former Material	VCfm		ASV
Half Space Sensitivity @1W/1M	db@1W/1M	dB	86.9	+/- 1.0db	Voice coil inner diameter	VCd	mm	19.3
Gap Height	Gh	mm	2		Rated Noise Power	P	W	60
Maximum Linear Excursion	Xmax	mm	0.2		Test Spectrum Bandwidth		2.5KHz-20KHz	
Ferrofluid Type	FF		APG027N		Driver Size	Inch	19 mm	
Driver Mass	Kg		0.17					

Frequency and Impedance Response

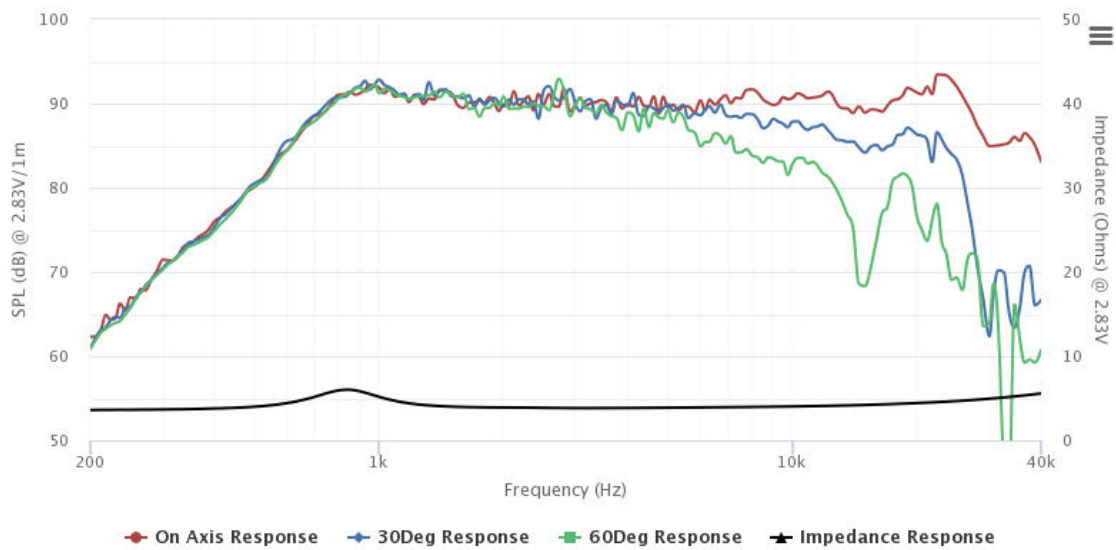

Highcharts.com