



# ET 338-104

## Elite Tweeter,

### Ø 104mm, 8Ω

#### SPECIFICATIONS

General Data		
Overall Dimensions	<b>DxH</b>	104mm(4.09")x66mm(2.59")
Nominal Power Handling (DIN)	<b>P</b>	200W
Transient Power 10ms		1000W
Sensitivity 1W/1M		92.5dB SPL
Frequency Response		1,800-20,000 Hz
Cone/Dome Material		Acuflex™ hand coated soft dome
Net Weight	<b>Kg</b>	1.08

Electrical Data		
Nominal Impedance	<b>Z</b>	8Ω
DC Resistance	<b>Re</b>	5.2Ω
Voice Coil Inductance @ 1KHz	<b>LBM</b>	0.09mH

Voice Coil and Magnet Parameters		
Voice Coil Diameter	<b>DIA</b>	28mm
Voice Coil Height		2.7mm
HE Magnetic Gap Height	<b>HE</b>	2.5mm
Max. Linear Excursion	<b>X</b>	
Voice Coil Former		Aluminum
Voice Coil Wire		Hexatech™ Aluminum
Number Of Layers		2
Magnet System Type		Triple Ferrite
B Flux Density	<b>B</b>	1.95 T
BL Product	<b>BXL</b>	6.3 N.A

T-S Parameters		
Suspension Compliance	<b>Cms</b>	
Mechanical Q Factor	<b>Qms</b>	
Electrical Q Factor	<b>Qes</b>	
Total Q Factor	<b>Qts</b>	
Mechanical Resistance	<b>Rms</b>	
Moving Mass	<b>Mms</b>	0.44 g
Eq. Cas Air Load (liters)	<b>VAS</b>	
Resonant Frequency	<b>Fs</b>	700 Hz 10%
Effective Piston Area	<b>SD</b>	6.0 cm <sup>2</sup>

- #### Features
- \* 104mm IDR™ Improved Dispersion Recess
  - \* Aluminum Face Plate
  - \* Large Hexatech™ aluminum voice coil
  - \* Replaceable Acuflex™ dome / coil assembly
  - \* Triple magnet system
  - \* High power handling
  - \* Sturdy gold plated input tags

#### Unit Dimensions

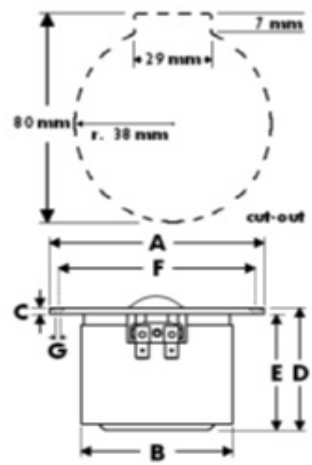

A - Overall diameter	104mm
B - Magnet/Chamber diameter	76mm
C - Flange thickness	3mm
D - Overall height	66mm
E - Magnet/Chamber depth	63mm
F - Mounting holes location diameter	94mm
G - 6 Mounting holes, at 60° interval,	
inner hole diameter	Ø 3.7mm
pocket	h 1mm, Ø 7mm

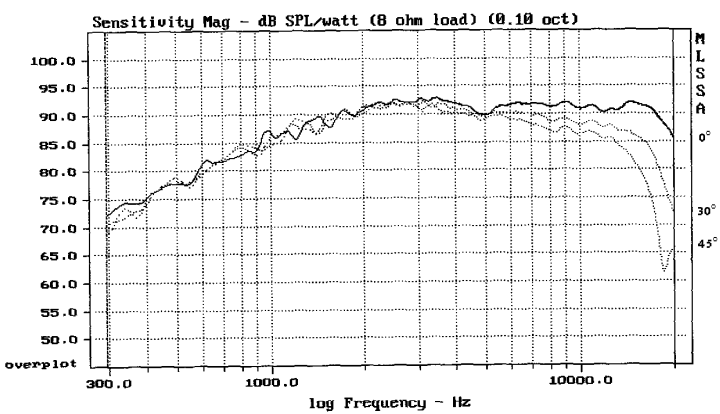
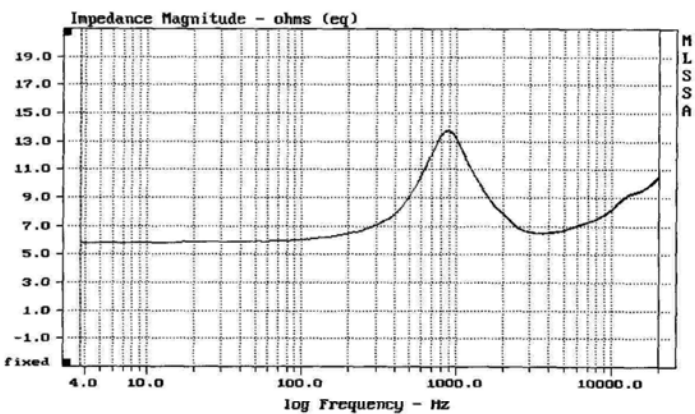

Faceplate finish available in either Black or Silver

Morel operate policy of continuous product design improvement, consequently specifications are subject to alteration without prior notice.