



# ELLIPTICOR

## MIDWOOFER

## 18WE/8542T00

With the Ellipticor family a long tradition of circular motor structures and their inherent breakup behavior has been broken since one of its key features is an elliptical voice coil and magnet gap. In combination with the powerful SD AirCirc magnet system the 18WE has high sensitivity, very low distortion, and has an extremely fast response to transients. Above all a TRUE TO LIVE sound which makes 18WE/8542T00 one of the very best midwoofers on the market!

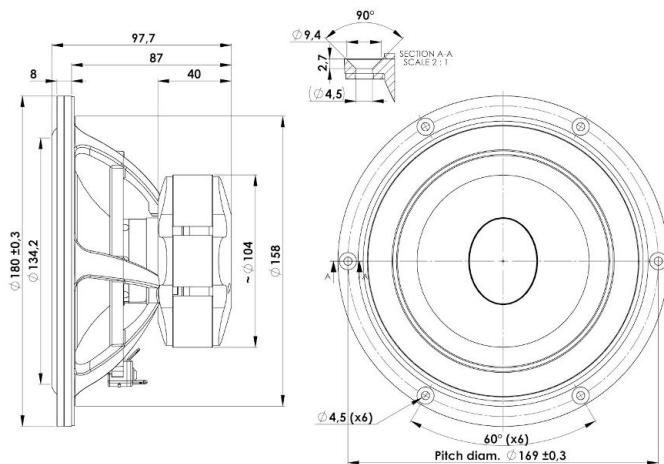

### KEY FEATURES:

- Elliptic voice coil
- High sensitivity (SPL)
- Unusually low distortion
- Very low mechanical losses
- AirCirc optimized magnetsystem
- Flexible appearance with replaceable decor ring

#### T-S Parameters

Resonance frequency [fs]	50 Hz
Mechanical Q factor [Qms]	5.01
Electrical Q factor [Qes]	0.34
Total Q factor [Qts]	0.32
Force factor [Bl]	9.7 Tm
Mechanical resistance [Rms]	1 kg/s
Moving mass [Mms]	16 g
Compliance [Cms]	0.64 mm/N
Effective diaph. diameter [D]	130 mm
Effective piston area [Sd]	133 cm <sup>2</sup>
Equivalent volume [Vas]	16 l
Sensitivity (2.83V/1m)	89 dB
Ratio Bl/√Re	3.86 N/√W
Ratio fs/Qts	156 Hz

#### Notes:

IEC specs. refer to IEC 60268-5 third edition.  
All Scan-Speak products are RoHS compliant.  
Data are subject to change without notice.  
Datasheet updated: March 22, 2018

#### Electrical Data

Nominal impedance [Zn]	8 Ω
Minimum impedance [Zmin]	7.6 Ω
Maximum impedance [Zo]	100 Ω
DC resistance [Re]	6.3 Ω
Voice coil inductance [Le]	0.14 mH

#### Power Handling

100h RMS noise test (IEC 17.1)	50 W
Long-term max power (IEC 17.3)	100 W

#### Voice Coil & Magnet Data

Voice coil diameter	35/45 mm
Voice coil height	20.4 mm
Voice coil layers	2
Height of gap	5 mm
Linear excursion	± 7.7 mm
Max mech. excursion	± 12 mm
Unit weight	1.7 kg





ELLIPTICOR

## MIDWOOFER

18WE/8542T00

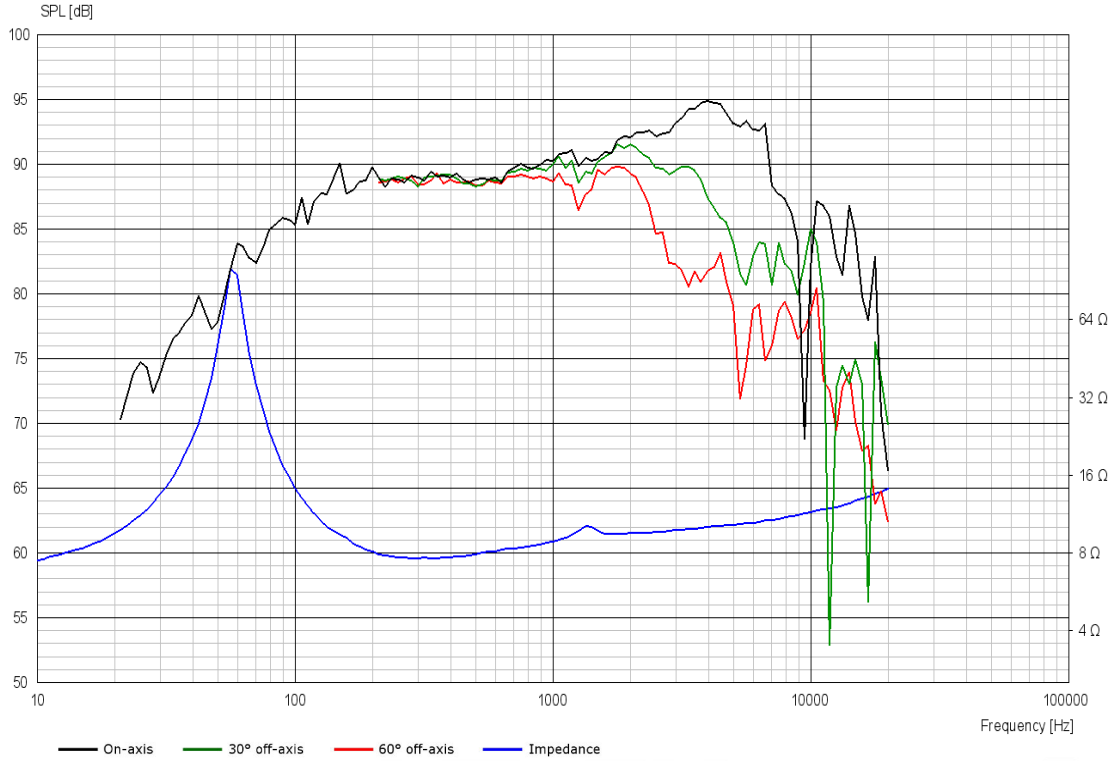

## Advanced Parameters (Preliminary)

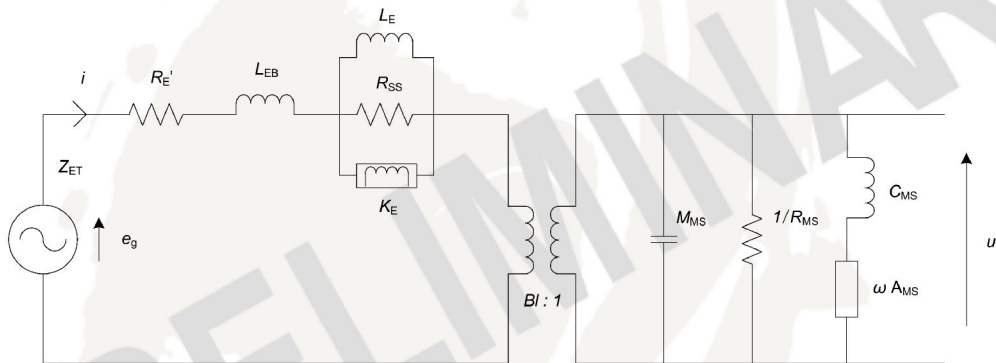

### Electrical data

Resistance [Re']	- Ω
Free inductance [Leb]	- mH
Bound inductance [Le]	- mH
Semi-inductance [Ke]	- SH
Shunt resistance [Rss]	- Ω

### Mechanical Data

Force Factor [Bl]	- Tm
Moving mass [Mms]	- g
Compliance [Cms]	- mm/N
Mechanical resistance [Rms]	- kg/s
Admittance [Ams]	- mm/N

SCANSPEAK